



1979

## A Neuropharmacological Analysis of Retinal Function in the Isolated Perfused Frog Eye

Anthony Louis Marchese  
*Loyola University Chicago*

Follow this and additional works at: [https://ecommons.luc.edu/luc\\_diss](https://ecommons.luc.edu/luc_diss)

 Part of the [Pharmacology Commons](#)

---

### Recommended Citation

Marchese, Anthony Louis, "A Neuropharmacological Analysis of Retinal Function in the Isolated Perfused Frog Eye" (1979). *Dissertations*. 1861.

[https://ecommons.luc.edu/luc\\_diss/1861](https://ecommons.luc.edu/luc_diss/1861)

This Dissertation is brought to you for free and open access by the Theses and Dissertations at Loyola eCommons. It has been accepted for inclusion in Dissertations by an authorized administrator of Loyola eCommons. For more information, please contact [ecommons@luc.edu](mailto:ecommons@luc.edu).



This work is licensed under a [Creative Commons Attribution-NonCommercial-No Derivative Works 3.0 License](#).  
Copyright © 1979 Anthony Louis Marchese

A NEUROPHARMACOLOGICAL ANALYSIS OF RETINAL FUNCTION  
IN THE ISOLATED PERFUSED FROG EYE

By  
Anthony L. Marchese

A Dissertation Submitted to the Faculty of the Graduate School  
of Loyola University of Chicago in Partial Fulfillment  
of the Requirements for the Degree of  
Doctor of Philosophy

February  
1979

## ACKNOWLEDGMENTS

I wish to acknowledge with warmest appreciation my thanks and admiration of Professor Alexander H. Friedman, my advisor, friend and confidant without whom this work would not have come to fruition. He has demonstrated an open-mindedness to my ideas that is refreshing and has given me a free hand to develop my ideas while gently guiding me through a morass of personal and technical difficulties that beset me during my tenure as a graduate student in the Department of Pharmacology. I shall always remember his understanding, patience, forbearance and total support and the significant role he has played in my life.

I am also obliged to many other people who aided me in accomplishing my doctorate. John Nash Ott must be singled out as the catalyst who triggered my interest in the area that became the subject of my dissertation and for facilitating my stay in graduate school. I wish to thank Dr. Alexander G. Karczmar, who accepted and supported me as a graduate student. I wish to commend fellow graduate students, Gerry DeVries and Mike Avram for their willingness to help and their help. I am grateful to members of the Ophthalmology Department, especially Drs. McDonald, Kearns and Maggiano for their interest, receptivity and

generosity in many ways. My friend, Ernest Dallafior is acknowledged for his support and technical input. I am also grateful to the Photography Department personnel, especially Margaret Conneely, Bob Vick and Alvin Hayashi. Richard Fryrear deserves thanks for computer plotting of data and my cousin, Lucian Marchi, who supplied much-needed keypunching. I wish to acknowledge the dedication of Ruth Lindsay who typed the reader's copy of the dissertation.

My final acknowledgment is to my very dear and understanding wife, Sandi, whose determination, energy and concern for detail and perfection has made the finalization of this work a reality.

## VITA

Anthony Louis Marchese, the son of George Marchese and Concetta (Fiorentino) Marchese, was born November 24, 1927.

His elementary education was obtained in Chicago, Illinois at Our Lady of Pompeii School and secondary education at St. Ignatius High School, where he graduated in 1945.

He majored in biology and minored in chemistry and philosophy, receiving his Bachelor of Science degree from Loyola University of Chicago in 1957.

He was affiliated with John Ott Pictures, Inc./Time-Lapse Research Foundation, from 1956 until he was accepted as a graduate student at Loyola University of Chicago at the Medical Center in 1968, and became a advisee directed by Dr. Alexander H. Friedman, Department of Pharmacology. He was an NIH trainee in Pharmacology from 1969 to 1976. Since 1974 he has had primary technical responsibility for all electrodiagnostic procedures conducted by the Department of Ophthalmology of the Stritch School of Medicine and the Section of Ophthalmology, Hines Veterans Administration Hospital.

## TABLE OF CONTENTS

	Page
ACKNOWLEDGMENTS . . . . .	ii
LIFE . . . . .	iv
LIST OF TABLES . . . . .	viii
LIST OF ILLUSTRATIONS (or figures) . . . . .	ix
CONTENT OF APPENDICES . . . . .	xii
INTRODUCTION . . . . .	1
REVIEW OF RELATED LITERATURE . . . . .	3
AN OVERVIEW OF RETINAL STRUCTURE AND FUNCTION.	3
The Photoreceptors . . . . .	7
The Bipolar Cell . . . . .	15
The Horizontal Cell . . . . .	17
The Amacrine Cell . . . . .	19
The Ganglion Cell . . . . .	21
RETINAL NEUROTRANSMITTER SUSPECTS AND THEIR POSSIBLE FUNCTION . . . . .	26
Acetylcholine . . . . .	26
Catecholamines . . . . .	33
Serotonin (5-HT) . . . . .	39
Retinal Amino Acids . . . . .	41
Excitatory Amino Acids . . . . .	42
Glutamic and Aspartic Acids . . . . .	42
Depressant Amino Acids . . . . .	43
Gamma-Aminobutyric Acid (GABA) . . . . .	43
Glycine . . . . .	49
Taurine . . . . .	51
ELECTROPHYSIOLOGY . . . . .	53
The Electroretinogram . . . . .	56
The c-wave . . . . .	63
The b-wave . . . . .	65
The a-wave . . . . .	66
The d-wave . . . . .	68
The e-wave (delayed-off response) . . . . .	69

Oscillatory Potentials . . . . .	70
The Standing Potential (SP) . . . . .	72
The Compound Potential of the Optic Nerve . . . . .	74
Pharmacology of Retinal Blood Vessels . . . . .	77
Pharmacology of Choroidal Blood Vessels . . . . .	78
Blood Flow Regulation in the Eye . . . . .	78
<b>METHODS</b> . . . . .	<b>79</b>
Experimental Conditions . . . . .	79
Animals & Environmental Conditions . . . . .	79
Operative Procedures . . . . .	81
Electrodes . . . . .	95
Silver-Silver Chloride (Ag-AgCl) . . . . .	95
Calomel Electrodes . . . . .	101
Recording from the Optic Nerve . . . . .	108
Special Problems with the Perfused Eye . . . . .	108
Summary of Electronic Methods used with the Isolated Perfused Eye Potentials . . . . .	112
The Photostimulator . . . . .	115
Time-lapse ERG . . . . .	118
Experimental Design . . . . .	120
Data Handling, Treatment & Analysis . . . . .	121
Chemical Agents & Drugs . . . . .	122
<b>RESULTS</b> . . . . .	<b>125</b>
Drug Effects . . . . .	141
Norepinephrine . . . . .	147
Epinephrine . . . . .	171
Dopamine . . . . .	173
GABA . . . . .	174
Picrotoxin . . . . .	175
Glycine . . . . .	176
Strychnine . . . . .	176
Histamine . . . . .	177
Serotonin . . . . .	177
Cholinergic Drugs . . . . .	178
ACh . . . . .	178
Mecholyl . . . . .	179
Carbachol . . . . .	179
Edrophonium . . . . .	179
TEA & Hexaminethonium (C-6) . . . . .	179
Nicotine . . . . .	180

GENERAL DISCUSSION . . . . .	181
A CRITIQUE OF THE ISOLATED PERFUSED EYE PREPARATION . . . . .	204
SUMMARY . . . . .	212
CONCLUSIONS . . . . .	221
REFERENCES . . . . .	223
APPENDIX A . . . . .	253
APPENDIX B . . . . .	255
APPENDIX C . . . . .	257



LIST OF TABLES

TABLE		Page
I	THE CHOLINERGIC SYSTEM OF THE RETINA . . .	31
II	CHEMICAL AGENTS AND DRUGS . . . . .	123
III	SUMMARY: NUMBER OF PREPARATIONS PER DRUG .	142
IV	DOSE RELATED EFFECTS OF NE . . . . .	172
V	RATE OF CHANGE OF THE SP OF THE OPTIC NERVE IN $\mu$ V/min AFTER IONS OR DRUGS . . . .	253

## LIST OF FIGURES

1. Photomicrograph of a Section Through the Retina of the Isolated Perfused Frog Eye. 160 X p. 5
2. Comparison of ERGs Recorded in the Excised and Isolated Perfused Frog Eye. p. 59
3. Cross-Section of the Frog Optic Nerve Demonstrating its Vascular Supply. p. 82
4. External Vascular Anatomy of the Frog Eye. p. 84
5. Schematic Diagram of Heated Perfusion Chamber for Cat Isolated Perfused Eye. p. 87
6. Pressurized Perfusion Apparatus. p. 90
7. Responses of the Isolated Perfused Cat Eye to Xenon Flashes During Dark-Adaptation. p. 94
8. Schematic Diagram of Light-Tight Chamber for Frog Isolated Perfused Eye. p. 96
9. Isolated Eye Holder. p. 98
10. Construction Details of Miniature Calomel Half-Cell Electrodes. p. 102
11. Schematic Diagram of Electrode Placement, Isolated Perfused Eye. p. 106
12. Schema for Electrophysiological Recording of Isolated Perfused Frog Eye. p. 110
13. The Electroretinogram of the Isolated Perfused Frog Eye. Comparison of ERGs Recorded Simultaneously Using A.C. and D.C. Recording Techniques. p. 113
14. Arrangements of Components Controlling Light Stimuli. p. 116
15. Superimposed a and b-wave Responses to Increasing Stimulus Intensity. p. 126

16. Continuous Recording of c-wave Amplitude as a Function of Stimulus Duration. p. 129
17. Superimposed c-wave Responses to Stimuli of Increasing Duration. p. 131
18. The Action Spectrum of the SP of a Curarized vs. an Isolated Perfused Frog Eye. p. 133
19. Isolated Perfused Frog Eye in Response to Different Stimulus Wavelengths and Stimulus Intensities. p. 134
20. Growth of the c-wave Amplitude at Different Intensities at 405, 540 and 640 nm. p. 136
21. ERG Potentials as a Function of Stimulating Wavelength and Intensity. p. 139
22. Effect of Drugs on the Standing Potentials of the Eye and Optic Nerve of the Photically-unstimulated Frog Eye in a Pressurized Perfusion System. p. 144
23. Computer Plot of Dose Related Effects of NE on Components of the ERG and Optic Nerve Potential (ONP). p. 148
24. Computer Plot of Multiple Drug Effects on Components of the ERG and the ONP Constant Volume Perfusion. p. 151
25. Computer Plot of Drug Effects on Components of the ERG and the Optic Nerve Potential (ONP). p. 153
26. Computer Plot of Drug and Ion Effects on Various Components of the ERG, the Standing Potential of the Optic Nerve and Perfusion Rates. p. 155
27. Computer Plot of Drug and Ion Effects on Various Components of the ERG and ONP Under Constant Volume Perfusion and Sucrose Gap Recording. p. 158
28. Computer Plot of Dose-Related Effects of Dopamine and Haloperidol a Dopamine Antagonist on Components of the ERG and the "b"-wave of the ONP as a Function of Time. p. 160

29. The Effect of Perfused Dopamine on b-wave Amplitude of the ERG of the Isolated Perfused Frog Eye. p. 162
30. Computer Plot of Drug Effects on the Standing Potential of the ERG and the Optic Nerve and on the Amplitude of the c-wave. p. 163
31. Computer Plot of Cholinergic Drug Effects on ERG and ONP Components. Constant Volume Perfusion and Sucrose Gap Recording of ONP. p. 165
32. Computer Plot of Drug-related Effects on Components of the ERG and ONP with Special Emphasis on the Latter. p. 168
33. The Effect of GABA on the b-wave (ERG) and the Late Component of the Optic Nerve Potential. p. 170

CONTENT OF APPENDICES

	Page
APPENDIX A . . . . .	253
TABLE IV Rate of Change of the SP of the Optic Nerve in $\mu\text{V}/\text{Min}$ after ions or Drugs	
APPENDIX B . . . . .	255
Composition of Physiological Saline Solutions Used to Perfuse the Frog Isolated Eye Preparations	
APPENDIX C . . . . .	257
Miscellaneous Drug Effects	

## INTRODUCTION

The eye transmits one-third of all sensory information reaching the central nervous system, yet is a "terra incognita". Much is known of the structural organization of the retina, its topological representation within the brain and its widespread effects of body function. Within the retina we have grossly mapped and identified an impressive array of neurotransmitter suspects, but we do not understand the role they subserve in channelling information distally for somewhat specialized and restricted actions. We are just beginning to understand the interplay that takes place between the retina and the retinal pigment epithelium (RPE) and its possible significance. To extend our understanding of the global and intimate function of the retina and associated structures it has been necessary to devise a viable, durable experimental preparation that retains principle features of the functioning eye in situ and permits the investigator to manipulate a variety of parameters. The dissertation will describe the development and advantages of the isolated intact perfused frog eye as a technique for the examination of the electrophysiology and neuropharmacology of the whole eye perfused through its own circulatory system (albeit in the absence of centripetal and some centrifugal

influences). It will demonstrate in a qualitative manner, the usefulness and advantages of this model over extant procedures in assessing the effects of drugs on retinal and whole eye function. It will show the feasibility of studying the gross electrical output from the eye by examining the optic nerve potential thus enabling one to gain information heretofore only possible by computer averaged transient of visually-evoked responses (VER). Dynamic aspects of retinal function will be illustrated and discussed using material derived from an original technique, viz., the time-lapse electroretinogram (TLERG). The discussion will include a critique of the newly-devised methods for studying eye function and will indicate the direction of future studies.

REVIEW OF RELATED LITERATURE  
AN OVERVIEW OF RETINAL STRUCTURE AND FUNCTION

The eye is derived from neural tissue and contains many, if not all, the neuronal elements present in the brain. The retina originates as an outgrowth of the embryonic diencephalon. The classic work of Polyak, The Retina (1941), essentially using the histological method of Cajal, left unanswered many questions with respect to structural organization. Sjöstrand (1949) extended the Golgi technique by remounting the Golgi stained preparations for electron microscopy and followed the fine processes to their synaptic terminations. Dowling and Boycott (1965) further elucidated features of the fine structure of primate retinal neurons, demonstrating ribbon synapses, "dyad" synapses and conventional synapses. Serial reconstruction electron microscopy and the Golgi electron microscopy technique was found to be extremely useful in untangling neural circuits (Kolb, 1970). The freeze-fracture method, Raviola & Gilula (1975), permits the determination of more intimate aspects of synaptic anatomy. Apart from rods and cones, the retina can be considered as grey matter utilizing many of the same mechanisms present in the brain for the transmission of information from one neuron to



another. The presence of the same neurotransmitters as in the brain and CNS, together with structures such as gap junctions, triads, reciprocal synapses and serial synapses suggests that the biochemical and bioelectrical parameters are functionally interwoven (Schmitt, et al., 1978).

Grossly, the eye is a globe composed essentially of three layers or coats. The sclera and cornea comprise the outer coat. The vascular choroid, the ciliary body and the iris form the middle layer. Finally, the retina, the innermost layer, coats the entire globe from within except for the anterior portion of the eye where it continues forward as the ciliary epithelium. The layered nature of the eye is apparent in fixed and stained sections of the eye using the light microscope. (Figure 1) Anterior to the choroid layer is the pigment epithelium which interdigitates with the neural retina. In the stratified structure of the neural retina one can recognize the following layers: (1) The outer segment or photoreceptor layer, (2) the outer nuclear layer (ONL), (3) the outer plexiform layer (OPL), (4) the inner nuclear layer (INL), (5) the inner plexiform layer (IPL), (6) the ganglion cell layer and (7) the nerve fiber layer. The large glial cells which extend from the outer limiting membrane to the inner limiting membrane and which run parallel to the vertically oriented cells are the Müller cells. These cells have fine processes enveloping

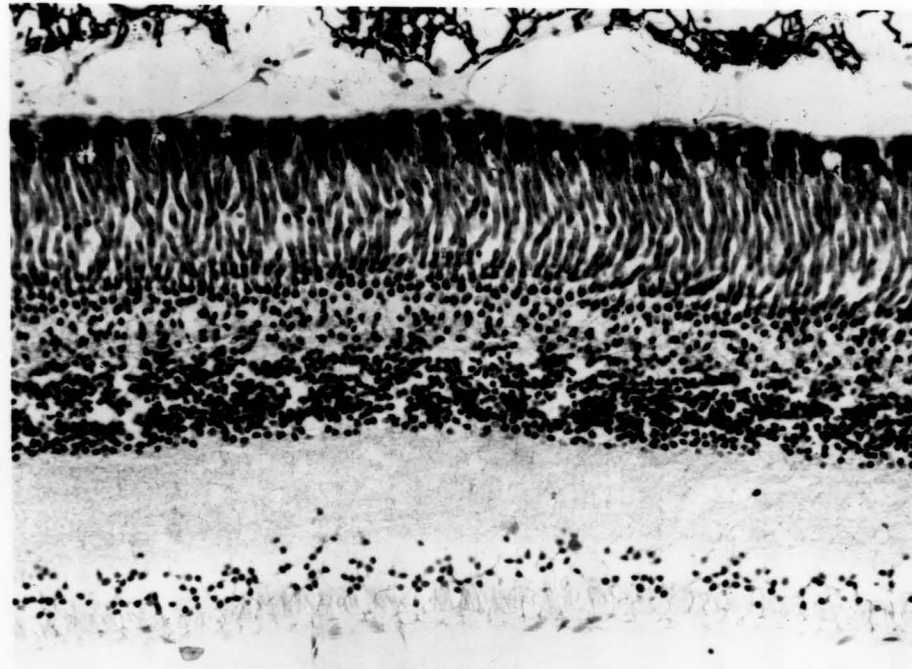

- Uveal melanocytes
- Choriocapillaris
- Pigment epithelium
- Photoreceptor  
outer segments
- Outer nuclear layer
- Outer plexiform layer
- Inner nuclear layer
- Inner plexiform layer
- Ganglion cell layer
- Nerve fiber layer

Figure 1 Photomicrograph of a section through the retina of the isolated perfused frog eye. 160 X.

all neurons in their immediate vicinity. Their nuclei are located in the INL. Junctional complexes seen in electron photomicrographs lying between Müller cells and photoreceptors from the "external limiting membrane". Mucopolysaccharides which are probably secreted by the photoreceptors occupy the space between the photoreceptor outer segments and the processes of the retinal pigment epithelium. Junctional complexes at the other end of the Müller cells form the so-called "inner limiting membrane". A blood-retinal barrier is formed by the cell junctions in the zonulae adherentes and occludentes between cells of the retinal pigment epithelium. Thus, the retinal pigment epithelium (RPE) becomes important because of its strategic position. Two-way traffic occurs here. Digestion products from the phagosomes resulting from disc-shedding of the photoreceptors move toward Bruch's membrane, i.e., posteriorly from the retina. These materials finally exit through the choriocapillaris. Oxygen and other blood-borne materials necessary for retinal metabolism move through the RPE in the opposite direction, i.e., toward the retina. The circulation of the inner half of the primate retina is supplied by the central retinal artery - a feature missing in other vertebrates.

In primates, occlusion of the central retinal artery leads to rapid degeneration of the neural part of the

retina. In the frog eye, the subject of this thesis, there are structures in the blood vessels which control its micro-circulation (cf. Duke-Elder, 1958). In the hyaloid vessels of the membrana vasculosa of the retina are unusually prominent contractile cells which may serve the function of switching from one circulating system to another in response to light and visual activity (Rouget, 1873; Mayer, 1902).

In the retina there are five major neural cell types: (1) the photoreceptors (rods and cones), (2) horizontal cells, (3) bipolar cells, (4) amacrine cells and (5) ganglion cells.

### The Photoreceptors

The cell bodies of the photoreceptors lie in the ONL while their outer segments comprise the outer nuclear layer. The outer segment of the rod (ROS) contains a stack of 500 to 2,000 flat rod sacs connected to the inner segment by the narrow cilium. The inner segment contains numerous mitochondria, endoplasmic reticulum, nucleus and synaptic terminations. A major difference between rods and cones lies in the outer segment where the cone has numerous deep invaginations of the outer membrane. The rod sac membrane, or photoreceptor membrane, consists of a lipid bilayer of high fluidity containing rhodopsin molecules which rotate freely. Rhodopsin, the visual pigment, is a protein of

M.W. 39,000. It is composed of vitamin A or retinal (the aldehyde of retinol) joined to the opsin-moiety (Wald & Brown, 1950). In cones, retinal combines with iodopsin or cyanopsin to form the cone visual pigments.

Retinal contains five double bonds joining the carbon atoms. The most stable form is the all-trans form. All known visual pigments utilize the 11 cis-isomer of retinal. Light isomerizes the cis-form to the trans-form. The 11-cis steric hindrance puts the molecule on a hair-trigger, thus yielding the greatest quantum efficiency when exposed to light (Hubbard, 1958). The first extraction of visual purple from frog retinas was accomplished by Boll (1876) and by Kühne (1878). Kühne also observed that complete regeneration occurred only if the retina was in contact with the retinal pigment epithelium. During light adaptation esterification of the all-trans retinal occurs. The ester is transposed to the photoreceptor outer segment and is isomerized to the photoactive 11-cis form.

When light stimulates the outer segment of a photoreceptor, a visual signal is produced. Penn & Hagins (1972) demonstrated in the absence of light, the existence of a dark photocurrent that depended on the inward flux of sodium ions. The mechanism whereby rhodopsin converted from all-cis to all-trans produces a change in the electric current of the photoreceptor is not yet understood. Hagins (1972)

summarized important properties of the transducer mechanism in rods and cones as follows:

- a) In both, there is a dark current that is suppressed by light.
- b) In both,  $\text{Na}^+$  ions must be present in the bathing medium in order for photocurrents to be obtained.
- c) In both, ouabain reduces the photocurrent and dark current to zero within a minute or so.
- d) In both, the dark current and photocurrents are largest in solutions containing less than  $10^{-5}\text{M}$  calcium as the calcium ion concentration is raised to 20 mM the dark current and photocurrent become smaller and finally disappears. The effects of external calcium ion concentration changes are rapid and reversible.
- e) Prolonged exposure of rods to very low calcium ion concentration (i.e.,  $10^{-8}\text{M}$ ) increases the stimulus energy required to produce half maximal photocurrent responses by more than tenfold. Brief exposure to 1 mM calcium restores their former sensitivity within a minute or two.
- f) Despite their physical separation from the plasma membrane, nearly all of the rhodopsin-bearing internal discs of rods are capable when illuminated, of suppressing the dark current through the plasma membrane.

From these properties of photoreceptors, Hagins has hypothesized that:

- 1) A calcium ion specific pump mechanism keeps the  $\text{Ca}^{++}$  ion concentration ratios lower in the cytoplasm of the outer segments than in the intradisc and extracellular spaces.
- 2) Internal calcium reacts reversibly at sites where the dark current enters and blocks the sodium ion permeability.
- 3) The permeability of the disc membranes to  $\text{Ca}^{++}$  ions is transiently increased by light, thus allowing the entry of more than one calcium ion per photon.

Bonting & Daemen (1976) have shown that frog and cattle rod outer segments have a remarkably high calcium content when they are isolated rapidly and with certain precautions (such as having ATP present, avoiding physical damage to photoreceptors, etc.). Osmotic lysis of isolated frog outer segments enable one to demonstrate that the calcium is mainly located in the rhodopsin containing compartment, presumably the rod sacs. Illumination releases no calcium from intact outer segments, but lysis before or after illumination allows the establishment of a light-induced release of calcium but not magnesium from the sedimentable calcium pool. The amount of calcium released per bleached rhodopsin molecule, if extrapolation to the single photon level is valid, would satisfy the conditions formulated by Hagins as determined from his electrophysiological studies according to Bonting & Daeman (1976).

Hagins laboratory further suggested that  $\text{Ca}^{++}$  is the internal transmitter liberated from the intradisc space into the intracellular space in cones (Yoshikami & Hagins, 1973; Hagins & Yoshikami, 1974).

Penn & Hagins (1969) using a microelectrode technique established the spatial distribution of dark current in rat rods. Current flows extracellularly from the cell bodies of the photoreceptors into the membranes of the outer segments. The similarity in both electrical signs and waveform

between the photocurrent and the PIII component of the a-wave is important because it lends further support to the hypothesis that the ERG a-wave is a measure of the activity of the photoreceptors (Brown & Weisel, 1961, a & b; Murakami & Kaneko, 1966).

The most direct route conveying the light stimulus to the brain would seem to be receptor-bipolar-ganglion cell thence to brain. Kolb & Famiglietti (1976) describe disynaptic (i.e., rod/rod bipolar/amacrine/ganglion cell) pathways in the cat retina. Lateral spreading of information occurs at both plexiform layers by means of laterally spreading neurons and gap junctions. There is a difference between rod and cone bipolars worthy of note. The rod bipolar of the cat never makes a direct synapse with any portion of the ganglion cell, whereas the cone bipolar can synapse directly on a ganglion cell and amacrine cell. The amacrine cell is therefore an internuncial neuron in the rod pathway. It is interesting that the ganglion cell response in the frog, i.e., at the level of the retina, is similar in complexity to the visual cortex activity of the cat (Maturana, et al., 1960). In Dowling's study (1968) comparing frog and primate retinas, he concludes that:

- 1)....there is a considerable amount of synaptic interaction between amacrine processes in the inner plexiform layer of the frog.
- 2)....in most instances the bipolars do not contact ganglion cell dendrites directly, but instead feed onto the amacrine cells.
- 3)....the ganglion cells in the frog are primarily influenced by the



amacrine cells and not by direct bipolar contacts.

There are nearly four times as many amacrine synapses in the frog retina as in the primate, many of these are serial synapses between two or more amacrines. These play a role in the complexity of the responses from frog ganglion cells. Dowling states:

....it seems doubtful that one could ever understand the complex synaptic interactions occurring among amacrine cell processes in the inner plexiform layer of the frog by single unit recordings from any one of the cells contributing processes to the inner plexiform layer. It is questionable whether even multiple-cell recordings could yield this information. To understand the functioning of the plexiform layers in the retina, additional techniques must be employed....

Cones as well as rods hyperpolarize to light stimuli. They both respond in a graded fashion to a range of about 3.5 log units of intensity. When the stimulus ceases however, there is an important difference between the two. Cones rapidly return to the pre-stimulus level, whereas rods remain hyperpolarized returning to the dark level very slowly. The amount of stimulus required for a response is also different. Five quanta per second are required for rods and about 100 quanta per second for cones. Significant bleaching of the photopigment occurs at about  $10^7$  X higher than threshold. These physical phenomena are significant for understanding the process of adaptation in rods and cones. The cones seem to have an inherent "range-changing" control which allows them to shift their range or response when an

increased background level of light is supplied but this mechanism is absent in rods which "saturate" with no ability to shift along the log intensity axis (Werblin, 1973). Thus, at intensities below saturation, rods are better indicators of background levels.

The morphological basis of how the light message is transmitted to the second order neurons is derived from electron microscopy which shows that both bipolar and horizontal cells make direct synaptic contact with the photoreceptors (Stell, 1967). Normally, in the dark photoreceptors exhibit the dark current which manifested as a sustained depolarization. When triggered by light these cells transiently hyperpolarize in a graded fashion in response to different stimulus intensities. Trifonov (1968) electrically depolarized receptor terminals to produce a transient depolarization of horizontal cells. He considered this response to be evidence that the transmitter terminals released the transmitter which evoked the horizontal cell response. Trifonov formulated an hypothesis based on this work that the photoreceptors continuously release transmitter substance from their synaptic terminals in the dark, however release is curtailed or even stopped when a light stimulus occurs. Transmitters are thought to act by opening ion channels in the post synaptic membrane. This implies a reduction of the electrical resistance of the post-synaptic

(horizontal cell) membrane. Toyoda et al., (1969) supported Trifonov's hypothesis. They demonstrated that when stimulated by light there was a consequent decrease in horizontal cell input resistance. Kaneko and Shimazaki (1975) used divalent cations to antagonize the effects of calcium which is known to be necessary for transmitter release. The effects of stimulation by transretinal current in their calcium antagonized preparation is offered as evidence for chemical transmission from photoreceptors to bipolar and horizontal cells. They cite the work of Murakami, et al., (1972, 1975) who have shown that glutamate and aspartate produce potential changes in the second order neurons, the horizontals and bipolars. The role of these substances as possible transmitters requires more evidence.

Morphologically, the termination of rods is described as spherules and the cone, as pedicles (Cohen, 1972). At the presynaptic region of contact between 1st and 2nd order neurons is the ribbon synapse, a dense bar lying next to the presynaptic membrane. There is an orderly array of synaptic vesicles surrounding the terminus of the ribbon. Sjöstrand (1958) and DeRobertis and Franchi (1956) were among the earliest workers to study this structure with the electron microscope. Wagner (1973) noted in the adult dark adapted cichlid fish, Nannacara, a highly significant reduction of the number of synaptic ribbons in cone pedicles. In rod

spherules there is apparently no change in the number of synaptic ribbons in either light or dark adapted animals. Ribbon synapses with synaptic bars also occur in the sensory cells of the bullfrog labyrinth. Osborne & Thornbill (1972) reported a highly significant reduction in electron density of the synaptic bars in the labyrinth sensory cells after challenge with monoamine depleting drugs, reserpine and guanethidine. They suggest that the synaptic bars are intracellular storage sites for a monoamine neurotransmitter and that it is a catecholamine. Wagner (1973) suggests that if the reduction in number of synaptic bars in dark treated cone pedicles is an effect similar to that reported in the bullfrog ear by Osborne & Thornbill (1972). It would favor the hypothesis that the synaptic bars are a storage site for transmitter substances.

### The Bipolar Cell

The photoreceptors drive the bipolar and horizontal cells. The bipolar cells are the second order neuron responsible for the transfer of information to the brain. Cajal (1973) described three types of bipolar cells in the vertebrate retina: (1) the displaced bipolar, i.e., the ovoid or pyriform cell body outside the OPL with an ascendent process; (2) the large or outer bipolars with cell bodies located immediately below the OPL and (3) the small or inner bipolar cell with cell bodies that occupy a large

portion of the INL. He suggested that the large bipolar cells were associated with rods and the smaller cells with cones. These cells as determined by their electrophysiological responses depend upon input originating in the synaptic interactions between photoreceptors and horizontal cells. The bipolar cells generate only slow, graded potentials in response to light stimuli. Two types of bipolar cells have been distinguished by their intracellular responses. With the first type, steady spot illumination produces a sustained depolarization. The same illumination in the second type produces a sustained hyperpolarization. If an annulus of light is presented which surrounds the central spot stimulus, the response of either type of bipolar cell is reduced, thus indicating the presence of an antagonistic center surround mechanism. The central response originates from a direct photoreceptor-bipolar cell synapse. However, the antagonistic-surround response appears to be mediated by a horizontal cell-bipolar cell synapse, the horizontal cell carrying the message of the photoreceptors activated by the annular stimulus (Werblin & Dowling, 1969). Kaneko (1970) did not find any morphological distinctions between the two electrophysiologically-different bipolar cell types.

In all species studied, bipolar cells terminate in a synaptic arrangement termed a dyad. A dyad is comprised

presynaptically of the ribbon bipolar cell terminal which contacts two postsynaptic elements. These can be a ganglion cell dendrite and an amacrine process or two amacrine processes (Dowling, 1968) and very rarely two ganglion cell dendrites (Dubin, 1970).

### The Horizontal Cell

The horizontal cell like receptors and bipolars responds to stimulation with slow graded potentials. Cajal (1973) found only two types of horizontal cells in the frog retina: they are, (a) outer horizontal cells, the smaller of the two, with triangular or semi-lunar cell bodies which give rise to very long, thin, branching dendrites. (b) The inner horizontal cells; these cells have a larger cell body with shorter and very numerous dendrites. Dowling, et al., (1966) found two types of horizontal cells in the rabbit and cat retina, viz., a large cell and a small cell. The large cell, without an axon, had a dendritic field of 300 to 500  $\mu\text{m}^2$  while the small cell had an axon and a dendritic field of only 100 to 200  $\mu\text{m}^2$ . Stell (1967) first reported the presence of only two types of horizontal cells, one for cones and one for rods, but later, after continuous application of the Golgi technique, he found three types of horizontal cells related to cones (Stell & Lightfoot, 1975) in addition to the single rod horizontal cell type. The catecholamine fluorescence technique reveals that a new type

of neuron the interplexiform cell also makes synaptic connection with horizontal cells (Dowling & Ehinger, 1975; Dowling, et al., 1976). Stell (1976) noted that the difference in the size and shape of horizontal cells found in different vertebrate species is very great. Lateral activity in the outer plexiform layer is accomplished through the functioning of the horizontal cells.

Svaetichin (1953) obtained a response from the inner-nuclear layer of the fish retina he originally believed to be a cone potential but in reality originated from the horizontal cells. This potential was termed the S-potential. MacNicholl & Svaetichin (1958) later classified S-potentials into two types: 1) the L, or luminosity potentials, i.e., light sensitive and, 2) the C-potentials, which are wavelength sensitive. Naka (1972) found that stimulation of horizontal cells with a depolarizing stimulus caused a ganglion cell response like that evoked with a spot of light while a hyperpolarizing stimulus behaved like an annulus. A feedback mechanism from horizontal cells to cones was demonstrated by Baylor, et al., (1971) who found that externally-applied hyperpolarization of horizontal cells lead to depolarization of cones.

### The Amacrine Cell

Amacrine cells were classified by Cajal (1973) into two main types - stratified and diffuse. The stratified cells were further subdivided according to the levels at which they have their ramifications, i.e., to any of five levels. The processes of the amacrine cells terminate by making synaptic contacts of "more conventional morphology" (Dowling, 1968) with densely-packed synaptic vesicles on the amacrine-cell side. They make synaptic contact with bipolar terminals, ganglion cell dendrites and perikarya, and other amacrine cell processes. Pairings of ganglion cell dendrites with amacrine processes occur at about 80% of the dyads in monkey and cat retinae while in the frog amacrine-amacrine cell pairing of dyads, occurs about 75% of the time. Very many conventional synapses of amacrine cells occur as a feature of all vertebrate species. Amacrine cells display another interesting feature. At many dyads the amacrine cell is post-synaptically located but it is also observed to make another synapse nearby in a reverse direction onto a bipolar cell suggesting that a local feedback process occurs. This junction is termed a reciprocal synapse. Another important feature of amacrine cells is that they sometimes synapse with adjacent amacrine cells. As many as four consecutive synapses of this serial type have been observed. The terminal synapse can be on an



amacrine process or a ganglion cell process (Dowling, 1968; Dowling & Werblin, 1969; Dubin, 1970).

These observations together with comparative receptive field studies of ganglion cell activity have revealed two types of receptive field organization. They are: (1) simple, in which fields can be mapped satisfactorily with static spots of light illuminating the retina, and (2) complex, these receptive fields require a more complex stimulus arrangement than a simple spot of light. When the anatomy is compared with the aforementioned receptive fields, one notes that the simple receptive field organization uses dyad pairings consisting of one amacrine and one ganglion cell with a relatively-few serial synapses. The monkey and cat have such retinae. Complex receptive field organization is seen in the frog and pigeon retinae and these species have dyad pairs consisting mainly of two amacrine cell processes together with many serial synapses (Dowling, 1968; Dubin, 1970).

It is clear that the trend toward complexity of retinal structure correlates with less encephalization of neural function; so that in man and monkeys, in which the cortex is best developed, the retina is simplest. In frogs and pigeons in which the cortex is least developed, the retina is most complex. (Dowling, 1968)

Electrophysiologically, the amacrine cells of Necturus respond phasically to light-evoked stimulation. They are the first cells in the visual pathway to do so. Werblin & Dowling (1969), Matsumoto & Naka (1972) found that some

amacrine cells in the frog respond with spiking activity superimposed upon large slow potentials while others respond with only large slow potentials. Chan & Naka (1976) suggested that the cells responding with "sustained" potentials are true amacrine cells (axonless neurons) and that the "transient" neurons (those with spike activity) may be a subclass of ganglion cells representing an alternative information processing network with a different retinal output. They noted that since the functional morphology of the vertebrate retina is an intricate problem, its solution must also be difficult. Only a small percentage of the amacrine cells can be specifically associated with them.

### The Ganglion Cell

The ganglion cells represent the third and last link of the chain of neurons in the retina. Their axons collectively form the optic nerve through which messages from the retina reach the brain. The perikarya of the ganglion cell form the ganglion cell layer, their dendrites reach into the inner plexiform layer.

Cajal's (1973) classification of frog retina cell types includes monostratified, polystratified and diffuse ganglion cells. The dendrites of the monostratified cells are seen at a distinct region, the bistratified cell terminals at two levels and the diffuse cells have ramifying processes and terminals throughout the inner plexiform

layer. Cajal noted that the monostratified cells were probably displaced amacrines (perhaps the "transient" cells described by Chan & Kaka (1976) and referred to in the previous section). Kalinina (1976) reported agreement with Maturana et al., (1960) as to the number of ganglion cells present in the frog retina. The latter reported almost a half-million ganglion cells in the eye of the frog. The population density of the five classes of neuron types represented decreases from the central portions of the retina to its periphery (Kalinina, 1976). Other classifications of ganglion cell types have been based on differences of perikarya (Polyak, 1941) or on distribution of terminal elements throughout the inner plexiform layer (Boycott & Dowling, 1969). Dowling (1970) suggested there are two basic functional types of ganglion cells: (1) the conventional type which receives its input from a bipolar cell, and (2) one found in abundance in complex retinae which receives its input from an amacrine cell, thus making the ganglion cell the fourth instead of the third neuron in the retinal linkage. The impulse mechanism responsible for carrying the retinal message to the brain originates in the perikarya of the ganglion cells. Byzov (1959) and Kaneko & Hashimoto (1969) have shown by means of antidromic stimulation of the optic nerve that the ganglion cells and not amacrine cells are responsible for the optic nerve impulses.

Hartline (1938) was one of the first to record the spikes or all-or-none potentials from single ganglion cells in the vertebrate eye. He found that all ganglion cells did not respond in the same manner to a light stimulus. Cells responding to light with a burst of spikes were called ON cells, those producing spikes at the beginning and end of a stimulus as ON-OFF cells, and those with discharges following only after the end of stimulation as OFF cells. He obtained responses from other ganglion cells beyond the selected area stimulated by light. Their response pattern was circular reaching a diameter of about 1 mm with the center responses being the strongest. He initiated the use of the term receptive field and defined it as "the area on the retina from which the discharges of that neuron can be influenced".

Using patterns of light to stimulate the unopened eyes of anesthetized cats, Kuffler (1953) found that there are only two basic receptive field types: the "ON" CENTER and the "OFF" CENTER. He too found the fields to be roughly concentric. He determined that a spotlike ON-receptive field and its surround region are always antagonistic. If the center and its surround are stimulated simultaneously they tend to suppress each other. The greatest response occurs when a "center" is completely filled with light. The greatest antagonism occurs when the surround is also

totally illuminated. In an OFF receptive field the antagonistic response originates in the center. These properties help to explain why diffuse illumination causes a weaker response to stimulation than patterned stimuli (spots, lines or edges). Maturana et al., (1960) using a teleological approach pondered the question regarding the frog's ability to distinguish food and natural enemies. They devised stimuli simulating the natural conditions under which frogs live including photographs of the frog's natural habitat and mapped their responses to these stimuli. They found through these responses that the ganglion cells form five natural classes. One class deals with the measure of light intensity-the other four function to perform "complex analytical operations". Their descriptive classification follows:

- Class 1. Sustained edge detection with non-erasable holding.
- Class 2. Convex edge detection with erasable holding.
- Class 3. Changing contrast detection.
- Class 4. Dimming detection.
- Class 5. Darkness detection.

Enroth - Cugell & Robson (1966) distinguished two types of "ON" center and "OFF" center fields in the cat based on their capacity to detect stable objects or those which move across the visual field. The steady type producing a sustained discharge are called X-cells, while the moving type, called Y-cells, produce a transient discharge

(Clelland et al., 1971). Stone & Hoffman (1972), using very fine tipped electrodes and antidromic stimulation found a class of cells which have very slow conduction velocities. They named these W-units since they could not be classified as X-or Y-Cells. Receptive field analysis suggests a high degree of stimulus specificity according to the complexity of the retina. The receptive fields of rabbit (Barlow et al., 1964) and frog (Maturana et al., 1960) with complex inner plexiform layers respond specifically to complex stimuli, whereas the receptive fields of the cat and monkey with simpler retinal organization respond to simple stimuli (Kuffler, 1953). Werblin & Copenhagen (1974) suggested that whether ganglion cells are tonic or phasic depends on interaction with the cells that drive them, i.e., tonic activity resembles bipolar activity while ganglion cell activity resembles amacrine cell activity. Wyatt & Daw (1976) suggest that amacrine cells may be responsible for the organization of properties of directional sensitivity of ganglion cell receptive fields.

## RETINAL NEUROTRANSMITTER SUSPECTS AND THEIR POSSIBLE FUNCTION

Information arriving at the photoreceptor is subsequently transmitted to the neural retina for processing and delivery to the CNS. This is achieved by coupling the action of photons with that of neurochemical transducers, the neurotransmitter suspects which abound in the retina. The study of these putative neurotransmitters has been the subject of several significant recent reviews (Graham, 1974; Ehinger, 1976; Neal, 1976a & Van Harreveld, 1977). The literature describing these retinal biogenic amines, both extensive and controversial, will be reviewed with respect to specific neurotransmitter suspects.

### Acetylcholine

The presence of acetylcholine (ACh) in the retina has been known for several decades. Graham (1974) recalculated the data contained in the early papers to present a more uniform reportage for comparison of the various investigations. He found approximately 30 nanomoles/gram of wet tissue weight was the level present in the vertebrate retina, a quantity similar to that found in the brain (cf. Walker & Friedman, 1972); Hanin, et al., (1970). The presence of the ACh synthesizing enzyme choline acetyl-transferase (choline

acetylase or ChAc) is necessary to establish ACh's role as a retinal neurotransmitter. Its activity has been demonstrated in the retinae of many species but it is either absent or present in very low concentration in the optic nerve. Neal (1976b) and Hebb (1955) indicated that the highest activity of ChAc anywhere is in the chicken retina. Retinal choline acetylase activity in the Hebb study ranged from 15.1  $\mu$  moles/hr./g wet tissue weight in chicken retina to 0.27  $\mu$  moles/hr./g in the dog and in the cat. In a study in which the turtle cone photoreceptors were maintained in cell culture, Lam (1972) demonstrated the synthesis of ACh in the cone cells. Graham notes that retinas that are predominantly of the cone type have the highest ChAc activity while animals with E-type, predominantly rod retinas, have much lower ChAc activity. The degradative enzyme, acetylcholinesterase (AChE), is present in the retina and has an activity that ranges from a maximum of 1,000  $\mu$  moles/hr./g of wet tissue weight to a minimum of about 300  $\mu$  moles/hr./g of wet tissue weight. This represents about a three-fold range of AChE in contrast with ChAc activity in which there is a 100-fold activity difference among various species.

There are no studies in the literature to indicate the localization of acetylcholine within the retina. Choline acetylase activity in the pigeon, rat and frog retina is concentrated primarily in the inner plexiform layer (IPL)



with lesser activity in the amacrine and ganglion cell layers. In the pigeon and rat the ChAc activity of the photoreceptor and horizontal cell layers is very low. In the frog retina no ChAc activity has been detected in these layers.

A number of histochemical studies of acetylcholinesterase distribution indicate that it is localized in the inner synaptic (plexiform) layer, (Nichols & Koelle, 1968; Reale, et al., 1971; Stell, 1972). Recently, a much more specific method for AChE localization became possible. Yazulla & Schmidt (1976) used  $\alpha$ -bungarotoxin ( $\alpha$ BTX), the principle venom from the banded krait, Bungarus multicinctus which binds to nicotinic receptors with high affinity. Sectioned retinas of goldfish and turtle were incubated in the presence of  $^{125}$ iodine  $\alpha$ BTX and the radiolabel was allowed to expose Kodak NTB-2 emulsion. When developed and examined under the light microscope, the peak density of silver grains was found in the OPL of both species with a smaller but secondary peak in the IPL. Although the concentration of ChAc reported in optic nerve seems to be low (Gruberg & Freeman, 1975), significant ACh synthesis in the optic tectum at the regions of the optic nerve terminals has been reported. To explain the discrepancy of the low optic nerve ChAc levels as compared with motor nerves in which ChAc is much higher, they offer two possible explanations:

1) the levels of ChAc might be normally low in the optic nerve but concentrated in the terminals.... 2) the high levels of ACh synthesis that they and others have observed in regions of the optic nerve termination are produced by non-retinal fibers ending there. To determine which of the suggestions might be correct, Freeman (1977) used a method of current source density analysis (Nicholson, 1973), which measures field potentials, to map evoked tectal potentials. It is claimed that this method which employs 6 electrodes in a planar array separated by 50 microns is capable of distinguishing between pre- and post-synaptic activity (Freeman & Nicholson, 1975). Freeman used a combination of electrical, light and iontophoretic drug stimulation to provide evidence that ACh is an excitatory neurotransmitter in the optic tectum possibly used by at least two different classes of ganglion cells, Class I & IV (classification of Maturana, et al., 1960). Class I ganglion cells are sustained edge detectors, while class IV ganglion cells are dimming detectors. Specifically, the retino-tectal synapses contain high levels of ACh, ChAc and AChE. Iontophoretically-applied acetylcholine and neostigmine excites while tubocurarine blocks the responses. Similar permeability mechanisms are indicated for exogenously applied ACh and the endogenous transmitter by the reversal potentials and when bungarotoxin ( $\alpha$ -BTX) which selectively binds to

nicotinic acetylcholine receptors was employed there was a long lasting abolition of post-synaptic responses in the toad optic tectum.

The following Table, Table I, derived from Graham (1974) gives an historical perspective of cholinergic retinal research. Part A emphasizes neurochemical content and enzyme activity. Part B summarizes electrophysiological effects of cholinergic drugs. It can be seen from Part A that the ontogeny of the cholinergic system apparently reflects the development of visual function and that changes in ACh content are species as well as laboratory dependent. The electrophysiological effects depend on the type of experiment, cell types investigated, doses and species used.

The standing potentials of the cat and rabbit retina were studied by Mita, et al., (1969). Animals anesthetized with pentobarbital and immobilized by d-tubocurarine were challenged by ACh injections ( $10^0$  to  $10^{-4}$  mg/kg) into the common carotid artery. At these high concentrations, ACh produced large and complicated variation of the N (negative) and P (positive) wave of the standing potential. Interruption of the blood flow by increasing intraocular pressure to 200 mmHg elicits variations in the corneo-retinal standing potential (SP). SP decreases progressively following decreases of  $O_2$  tension. When  $O_2$  tension is restored to normal a negative wave (N) followed rapidly by a positive

TABLE I THE CHOLINERGIC SYSTEM OF THE RETINA

A.) Neurochemical Changes Under Various Conditions

SPECIES	MEASURED/ ACTIVITY-OBSERVED	EXPERIMENTAL CONDITIONS	RESULTS & REFERENCE
Frog	ACh content	light adaptation	No difference noted from dark adapted retina (Therman, 1938)
"	"	" "	Slight increase with dark adaptation (Easton, 1945)
"	"	" "	10X decrease, light vs. dark adaptation (Langg, 1943)
Dog	ACh content	light adaptation	Blindfolded eye decreased 20% (7 to 50 days) and 60% (160 to 170 days) Chang et al., 1941
Rat	AChE Activity	light adaptation	Darkness 17 weeks = 20% reduction from normal activity (Lieberman, 1961)
"	"	" "	One eye covered, no difference in 5 days; 10% reduction in 20 days (Glow & Rose, 1966)
"	"	" "	Eyelid sutured at birth, at 10 months 10% reduction (p=0.025) from open eye (Maraini, et al., 1969)
Chicken embryo	ACh & AChE content	normal development	Gradual increase of AChE activity to 2 days post hatching, then levels off. ACh peaks @19 days, decreases and levels off, coincides with onset of pupilloconstrictor reflex (Lindeman, 1947)
Rabbit (neonate)	AChE (histochemical)	normal development	<ol style="list-style-type: none"> <li>1) AChE present at birth and localized in inner synaptic layer.</li> <li>2) Between 6th-8th day post partum, AChE activity increases to adult levels</li> <li>3) 1st electric potentials in optic lobe from light stimulus appear (Raviola &amp; Raviola, 1962)</li> </ol>

B. ELECTROPHYSIOLOGICAL EFFECTS OF CHOLINERGIC DRUGS

<u>Species</u>	<u>Preparation</u>	<u>Drugs</u>	<u>Results</u>
Frog	Eye cup	Atropine	Depressed <u>all</u> ERG waves (Therman, 1938)
Rabbit	Ganglion cell	ACh Physostigmine	Ganglion cells excited (Noell & Lasansky, 1959)
Cat	Single retinal neurons	ACh, eserine	Increased activity of ganglion cells
		ACh, 5-HT, (intra-arterial)	Produces same circulatory but opposite electrophysiological effect.
		ACh, epinephrine	Produces opposite circulatory but similar neuronal effect. ACh is probably <u>not</u> the main or excitatory transmitter since atropine & dihydro-B-erythroidin did not block the spontaneous or light-evoked activity of ganglion cells. (Straschill, 1968)
Bullfrog	Retina, isolated <u>in vitro</u>	Hexamethonium Atropine	Little effect on ERG b-wave completely blocked, d-wave enhanced. <u>Conclusion:</u> ACh mechanism associated with generation of b-wave at the onset of light stimulation (Val'Tsev, 1966)
Cat	Eye	ACh(intra-arterial) Sarin (an AChE inhibitor)	Depressed b-wave Alone, potentiates b-wave, followed by ACh causes a brief biphasic response, 1st increasing b-wave amplitude followed by a longer lasting decrease.
		Sarin & eserine Carbachol	Potentiates the b-wave Produces a long lasting increase of b-wave amplitude. (Von Bredow, <u>et al.</u> , 1971)
Rabbit	Isolated Retina	Physostigmine (low conc.) Curare(low conc.) (high conc.) Hexamethonium (nicotonic block.)	Marked increase of evoked response; some increase of spontaneous activity with a tendency for cycling. Depressed activity of all cells. Appearance of bursting type of activity. More effective in blocking activity than atropine (muscarinic blocker)suggesting presence of both excitatory & inhibitory circuits between photoreceptors & ganglion cells (Ames & Pollen, 1969).

wave (P) occurs and the SP recovers. Acetylcholine produces a series of slight positive elevations of SP in the rabbit but a large two stage depression of the SP on the cat at 10 mg/kg body weight.

The first neuropharmacological experiments on the isolated perfused eye of the cat were those of Marchese & Friedman (1973b). Niemeyer & Cervetto (1977) in this preparation reported that atropine had dose dependent effects. At the 0.1-0.5 mM dose the b-wave amplitude of the ERG first increased then decreased slightly. At the higher concentrations (1 to 5 mM) the b-wave amplitude decreased. In the optic nerve atropine at all concentrations depressed the ON b-response. This action is concentration dependent and completely reversible. The OFF d-response was affected in a more complex fashion. Negative (upward) components were enhanced while the positive (downward) deflections were depressed.

#### Catecholamines

Häggendel & Malmfors (1963) used the Falck-Hillarp fluorescence technique to examine the retina of the rabbit for catecholamines inasmuch as Carlson, et al., (1957) earlier had demonstrated that when noradrenaline was depleted by reserpine severe miosis and sensitivity to light occurred. Using fluorescence and neurochemical techniques, Häggendel & Malmfors (1965) demonstrated that dopamine-

containing neurons were located within the retina and were not connected with the cervical sympathetic chain. Their cell bodies are located in the inner nuclear layer. Very fine cell processes and varicosities occur in the inner plexiform layer.

Graham (1974) reviewed the histochemical localization of the catecholamines present in the retinas of various species. The outer layer of the inner synaptic region usually has the greatest fluorescence. In all animals studied but two (chicken and snake) catecholamine fluorescence occurs in the inner layer of the inner nuclear region. Considerable activity also occurs in the middle and inner layers of the inner synaptic region of most but not all species studied. Ganglion cell fluorescence occurs in 8 of 18 species, while none is found in the nerve fiber layer.

Two studies show catecholamine-induced fluorescence from the outer synaptic and including all parts of the inner synaptic layer of the retina of the new world monkey (primarily Cebus) (Laties & Jacobowitz, 1966; Ehinger & Falck, 1969). Ehinger & Falck further found the fluorescence extends to the ganglion cell layer.

Dowling & Ehinger (1975), using the Falck-Hillarp technique, reported a new type of amine-containing neuron that extends processes to both plexiform layers. Gallego (1971) using the Golgi method in the cat retina named cells

with similar morphological characteristics the interplexiform cell. In the goldfish and Cebus monkey retinas, these cells took up 5-6 dihydroxytryptamine (5-6 DHT), an indoleamine transmitter analog capable of labeling dopaminergic neurons that can cause the altered appearance of the fine structure of the neurons. This amounts to selective "staining" and makes subsequent identification with the electron microscope possible. A number of cells in the retina take up 5-6 DHT. When repeated doses of 5-7 dihydroxytryptamine are administered prior to labeling with 5-6 DHT, most of those cells (indoleaminergic) are destroyed selectively leaving only dopaminergic terminals. The pattern of synaptic organization of these cells was thus made evident. Dowling & Ehinger (1975,78) found no synapses onto interplexiform cells in the outer plexiform layer but found synapses occurring onto the process of these cells in the inner plexiform layer and that the direction of information in the interplexiform cell occurs in a centrifugal pathway from the inner to the outer plexiform layer. Atomized solutions of dopamine and pharmacologically-related compounds were used in the isolated goldfish retina; intracellularly-recorded light evoked responses from various cell types throughout these retinæ were monitored. It was found that dopamine and not noradrenaline or serotonin was effective in altering the intracellular responses of retinal neurons. This is



suggestive electrophysiological evidence that dopamine is the neurotransmitter of the interplexiform cell (Dowling, et al., 1976; Hedden & Dowling, 1978). Kolb and Famiglietti (1976) note that in the cat retina the synaptic terminations of the interplexiform cell are different and do not contain dopamine. Dowling, et al., (1976) suggest that the interplexiform cell is a general feature of the vertebrate retina. However, different species might use neurotransmitters other than dopamine.

Drujan, et al., (1965) found that catecholamine content of toad, frog and rabbit retinas was lower in the light-adapted state. The more impressive changes occurred with dopamine in the frog and rabbit retinas (i.e., 63% vs 57% lower in the former and latter, respectively). Dopamine was also reduced in the toad retina but epinephrine and dopamine levels were less in the dark-adapted retinas of the frog and rabbit. Only traces of norepinephrine could be measured in all three retinas under both states of light adaptation.

Gutierrez & Spiguel (1971) reported on the effect of reserpine, used as a monoaminergic depletor, on the ERG of the anesthetized cat. They noted that reserpine had no effect on the b-wave of the ERG but did, in fact, alter the genesis and development of the oscillatory potentials associated with the ERG by depressing those occurring on the

post b-wave peak. In a later report (1973), they reported l-dopa administered to reserpinized cats restored the altered oscillatory potential components. Wachtmeister & Dowling (1978) using the mudpuppy eye cup preparation report that oscillatory potentials may represent feedback loops within the retina and that the oscillatory potentials could be selectively depressed by GABA, glycine, glutamate and dopamine, but not by acetylcholine or carbachol. Kramer, et al., (1971a) reported that reserpine administered systemically in a dose which could deplete dopamine in the retina, caused a decrease in the "electroretinogram flicker suppression effect".

Straschill & Perwein (1969) reported that electrophoretically-applied dopamine (15 to 80 nA of 0.5 M. concentration) suppressed spontaneous activity in cat ganglion cells. Dopamine depressed the light-evoked excitatory reaction of retinal units (on, excitation - off, excitation). Inhibitory events such as on-inhibition, pre-and post-stimulus inhibition were augmented and prolonged. Results obtained with norepinephrine in "strength and time-course" were similar to those of dopamine, indicating that norepinephrine is also inhibitory in the retina. They noted that systemic l-dopa depressed the light-evoked activity of the optic nerve but did not affect the ERG. Ames & Pollen (1969) studied the isolated in vitro rabbit retina. They evaluated over

twenty pharmacological agents including norepinephrine, dopamine, methoxyamine and isoproterenol. They concluded that there was at least one adrenergic synapse with receptors which failed to distinguish between dopamine and norepinephrine but could not characterize it as an alpha or beta synapse.

Kramer (1976) in a series of elegant experiments, offered evidence to fulfill the five criteria required to establish dopamine (DA) as a retinal neurotransmitter. He confirmed the localization of catecholamines in retinal neurons seen with the Falck-Hillarp method using dopamine administered by a preretinal perfusion technique (Kramer, 1971) and monitored the accumulation of dopamine in these cells by radioautography. Little of the dopamine introduced via carotid infusion accumulated in the retina confirming the presence of a blood retinal barrier similar to the blood brain barrier. The presence of dopamine in the retina subsequent to preretinal perfusion rather than by carotid infusion was offered as evidence for the synthesis of dopamine locally in the retina. Radiochromatographic assay of the effluent of the preretinal perfusate contained the known metabolites of dopamine, i.e., norepinephrine (NE), dihydroxyphenylacetic acid and homovanillic acid. These metabolites can also be derived from NE but in this in vivo eyecup preparation the iris and other NE-containing

anterior structures were previously removed. Kramer stimulated his eye cup preparation with flickering light and collected the effluent of the perfusate. In this experiment, he sectioned the optic nerve to eliminate the possibility of a centrally stimulated uveal tract contribution of DA. He found that dopamine was released. In the dark-adapted eye the rate of  $H^3$ DA increases non-linearly with increasing stimulus rates. In the light-adapted state the release of DA is less clear since even a slow stimulus drives the DA release mechanism at a high rate.

Kramer offers no evidence of his own with respect to the ability of dopamine to elicit synaptic discharge activity but cites the work of Straschill & Perwein (1969) and Hedden & Dowling (1975, see also 1978). In support of the antagonism criterion necessary to establish DA as a retinal neurotransmitter, Kramer offers his preliminary impression (Kramer, et al., 1971a) of the effects of reserpine on ERG flicker suppression.

#### Serotonin (5-HT)

Serotonin occurs in many species. Levine (1962) extracted 5-HT from ocular tissues of the rabbit, guinea-pig, rat and monkey; and Welsh, (1964) found serotonin in fish, amphibian and reptile eyes. On the other hand, Häggendal & Malmfors (1965), using the Falck-Hillarp fluorescent histochemical technique, found no evidence of serotonin's

presence in rabbit retina and choroid preparation of untreated animals. However, a more recent study of Ehinger & Floren (1976) detected indoleamines including 5-HT in the inner nuclear layers of rabbit, cat and goldfish. Serotonin metabolism in the retina has been studied extensively by Baker (1966), Baker, et al., (1971) and Quay (1965). Quay (1965) reported the occurrence of hydroxyindole-o-methyltransferase, HIOMT (the enzyme responsible for converting N-acetyl serotonin into melatonin and previously thought to occur exclusively in the pineal gland) in fish, amphibians, turtle and chicken retina. Cardinali & Rosner (1971) studied the metabolism of 5-HT by incubating rat retinæ in vitro with serotonin ( $2^{-14}\text{C}$ ) binoxalate. Using a bidimensional thin layer chromatographic system, they identified 5-hydroxyindoleacetic acid, 5-methoxyindoleacetic acid, 5-hydroxytryptophol, 5-methoxytryptophan, N-acetylserotonin and melatonin. The presence of these serotonin metabolites indicates that the enzymes for the degradation of 5-HT are present in the retina, an important requirement for a potential neurotransmitter. Baker & Quay (1969) noted the presence of serotonin synthesizing enzyme, 5-hydroxytryptophan decarboxylase (5-HTPD) as well as monamine oxidase (MAO) and acetylserotoninmethyl transferase (ASMT) in the developing eye of Xenopus laevis, an amphibian. Hoff, et al., (1972) tested the 5-HT antagonist LSD, and found it

had no effect in the mouse eye. Cardinali, et al. (1972) assayed HIOMT in the cat retina. In reported but unpublished results, they found that continuous light inhibited retinal HIOMT activity. The action spectrum for HIOMT suppression in light was similar to the absorption spectrum of rhodopsin. Bubenik, et al., (1978) using immunohistological techniques with highly-specific antibodies identified melatonin in the rat retina. It is first detected in pups two days postnatally and reached adult levels by day twenty. Retinal melatonin, they determined, was derived by independent synthesis and not from the blood. Straschill (1968) found that intra-arterial 5-HT depressed spontaneous light-evoked activity in the cat retina. Ames & Pollen (1969) found that serotonin enhanced the activity of ganglion cells in the isolated rabbit retina. On the other hand, Straschill & Perwein (1969) noted that after iontophoretic application of 5-HT only 2 of 20 neurons responded weakly, while the remaining 18 neurons failed to respond at all. Ehinger (1976) generalized that apparent paradoxes in the results reported in various serotonin studies may simply reflect differences in methods of application as well as those due to species differences.

#### Retinal Amino Acids

There is evidence suggesting that various amino acids may be considered putative neurotransmitters in the retina

in addition to their involvement in many intermediate cell processes.

A. Excitatory Amino Acids

1. Glutamic and Aspartic Acid

Glutamic and aspartic acids behave as excitatory amino acids in mammalian CNS tissue (Curtis & Johnston, 1974). Glutamate and aspartate are diffusely distributed throughout the retina (Cohen, et al., 1973; Yates & Keen, 1976). However, the concentration of 2 to 3 mM glutamate and 0.5 to 1.25 mM aspartate in the avian and mammalian retinae (Davis et al., 1969; Pasantés-Morales, et al., 1972) is much lower than concentrations found in mammalian CNS tissue which is about 10 mM. Noell (1959) and Straschill (1968) reported that glutamate exerts an excitatory effect on retinal neurons.

Kishida & Naka (1967,1968) found that iontophoretic application of individual amino acids onto the retinal surface of a bullfrog optic cup preparation produced excitatory or depressant responses like those found in the central nervous system (Curtis & Watkins, 1960). L-glutamate and L-aspartate (0.1 mM) caused firing of ganglion cells and tended to enhance ON responses. At concentrations of 1 mM the spikes were abolished. Ames et al., (1967) noted that light-evoked optic nerve potentials were abolished by 5 mM glutamate. Glutamate enhanced spike activity

but not light-evoked spike activity (Ames & Pollen, 1969). Kishida & Naka (1967) noted that the ERG was unaffected by either amino acid. Murakami et al., (1972) reported that L-aspartate and L-glutamate rapidly and strongly depolarize carp horizontal cells resulting in the abolition of the S-potentials. Van Harreveld (1977) found no strong support for a transmitter function of glutamate and aspartate in the retina in the literature. Murakami et al., (1972) however, argued that since there is no way to measure or estimate the concentrations at the very site of the synapses, arguments against the role of these amino acids or transmitters are inconclusive. Cervetto & MacNichol (1972) recording intracellularly from the horizontal cells of the turtle retina report that both aspartate (50 mM) and glutamate (50 mM) suppressed light-evoked responses by depolarizing their membrane. Starr (1975) employing the rabbit in situ eyecup preparation found that 1 mM glutamate had little effect on the rabbit's ERG. See Wachmeister & Dowling (1978) for glutamate's depression of frog oscillatory potentials.

## B. Depressant Amino Acids

### 1. Gamma-Aminobutyric Acid (GABA)

Kojima et al., (1958) demonstrated the presence of GABA in the retina and choroid of the dog and ox. GABA was also found in the retinae of ten different mammals, as well as in a bird and a fish, (Kubicek & Dolenek, 1958).



There is a relatively-high concentration of GABA in the retina of 1.5 mM (Van Harreveld, 1977). These levels are similar to those found in brain (Voaden, 1976). Kuriyama et al., 1968) found that in rabbit retina the highest concentration of GABA and its synthesizing enzyme L-glutamic decarboxylase (GAD) occurs in the ganglion cell layer. Graham (1972) in frog retina found the highest GABA levels in the inner plexiform, inner nuclear and ganglion cell layer. Ehinger and co-workers (Ehinger, 1970, 1972; Ehinger & Falck, 1971; & Bruun & Ehinger, 1972), using  $H^3$  GABA and glycine determined autoradiographically that GABA and glycine were found in the inner plexiform layer in cells of the inner part of the inner nuclear layer (amacrine cells) and some cells in the ganglion cell layer of the rabbit retina. In an early postnatal study of GABA, its synthesizing enzyme (GAD) and its degradative enzyme GABA transaminase (GABA-T) were examined in the retina of the rat. At day four the concentration of GABA reached  $0.63 \mu M/100 \text{ mg protein}$ . GAD at day four was  $0.40 \mu M/100 \text{ mg protein}$  and rose to  $6.43 \mu M/100 \text{ mg protein/hr}$ . GABA-T level at day four was  $3.32 \mu M/100 \text{ mg protein/hr}$ . and rose to  $9.97 \mu M/100 \text{ mg protein/hr}$ . at day 90. GAD concentration was the lowest at birth. Its increased activity during development paralleled GABA concentrations and reached a peak at about 30 days ( $7.93 \mu M/100 \text{ mg protein/hr}$ .) then leveled off to adult

levels. GABA-T increased linearly and reached the adult level at 45 days. The increases of GABA, GAD and GABA-T levels, the authors suggest, are related to functional and structural modifications closely-connected with the initiation of visual activity (Macaione, et al., 1970). Graham et al., (1970) studied GABA, GAD and GABA-T levels in the frog retina during conditions of dark and light-adaptation and suggested that the GABA system is part of a neuronal mechanism involved in adaptation (the state of light or darkness has no effect on the content or localization of retinal glutamate). In the dark-adapted retina, GABA levels decrease more than 40% as does GAD. GABA-T levels seem to be independent of the adaptive state of the retina. The temporal decrease of retinal GABA correlates with a decrease in threshold excitability during dark-adaptation suggesting it is related to an inhibitory neural mechanism. Starr (1973) found no significant changes in the dark-adapted rat or chicken retina, but found decreases in GABA and GAD concentrations in the frog and goldfish. Only in the latter was this decrease considered significant. Starr quoting Graham (personal communication) states "The lack of reproducibility of this effect might possibly be attributable to seasonal variation, similar to that found for GABA and GAD levels in frog retina". DeVries & Friedman (1978) note that seasonal variations of sensitivity in the frog might

be responsible for the variations in control responses for GABA and picrotoxin experiments.

Starr & Voaden (1972) demonstrated an uptake mechanism for  $^{14}\text{C}$ -GABA in the rat retina. The process occurred equally in the light or dark adapted retina and involved 3 stages (vide infra). Voaden & Starr (1972) loaded the rat retina with radioactive GABA and the efflux of  $^3\text{H}$ -GABA into the bathing medium in response to rectangular pulses of current (50 Hz at 5 to 15 mA) was monitored. The loss of radioactivity occurred in three stages with different rate constants, suggesting that the GABA must be contained in three separate cell pools.

Noell (1959) was the first to demonstrate the effect of iontophoretic application of GABA to the retina of the rabbit. Ganglion cell responses to light evoked activity were rapidly and reversibly extinguished. Kishida & Naka (1967, 1968) also found an inhibitory effect of GABA on the in vitro frog retina. Staschill & Perwein (1969) iontophoresing GABA noted the quick and reversible inhibition of ganglion cell activity. Ames & Pollen (1969) reported similar effects. Murakami et al., (1972) demonstrated via intracellular recordings that GABA induced the hyperpolarization of horizontal cells. Graham & Pong (1972) studied rhythmic potentials recorded from the corneal surface of the albino rat eye. The rhythmic potentials could

be observed when the animal was under light anesthesia. The anesthetic agents used were penotobarbital, dial-urethane and barbital. The exclusion of a central origin of these potentials was assured by recording their appearance in preparations in which the optic nerve was crushed. Under deeper anesthesia with these agents, the rhythmic potential oscillations did not occur. When 10  $\mu$ l quantities of GABA antagonists (picrotoxin or bicuculline) were administered intravitreally to animals under deep anesthesia, rhythmic potentials of 5 to 9 cycles/ sec. appeared "unmasking" a barbiturate effect seen at the lighter anesthetic dose. The authors suggest that these potentials could be related to the bipolar ganglion-amacrine cell dyad or reciprocal synapse and GABA could be the inhibiting neurotransmitter mediating a negative feedback control process, i.e., a damping circuit designed to maintain homeostatic conditions. Graham & Pong (1972) suggest that this might be the mechanism of the "automatic gain control" which Rushton (1965) proposed as the system in which the retina reorganizes its neural network to handle various conditions of illumination.

Murakami et al., (1972) found that GABA has no appreciable effect on photoreceptor activity. Similar results were reported in the aspartate-treated retina of the frog by DeVries & Friedman (1978). Horizontal cells are hyperpolarized, thus blocking responses to light. Light-

evoked ganglion cell responses were depressed in the frog retina with GABA (0.16 to 10 mM), (Kishida & Naka, 1968) while Ames & Pollen (1969) report depression of rabbit retinal ganglion cell activity at 0.1 mM GABA. Noell (1959) applied GABA iontophoretically to the rabbit retina as did Straschill & Perwein (1969) to the cat retina. Both reported that spontaneous and light-evoked activity was suppressed.

GABA has been shown to affect the electroretinogram. Starr notes that the conflicting results of the effects of GABA on this field potential (Scholes & Roberts, 1964; Kramer et al., 1967) are probably due to the different light intensities used to elicit the response (Starr, 1975). Scholes & Roberts (1964) report that the chicken ERG was depressed at low intensities but that the a- and b-wave amplitude at high stimulus intensity was increased by intravenously administered GABA. Intravitreal injection of GABA produced b-wave depression at all stimulus intensities (Pasantes-Morales et al., 1973). They found that picrotoxin produced a transient reversal of this depression (Bonnaventure et al., 1974). Using the preretinal perfusion method of Kramer (1971) on the rabbit eye cup, Starr (1975) found that GABA produced an increase in the peak height of the b-wave in response to white light (Xe discharge, 360 to 530 nm) at concentrations ranging from 0.1 mM and 1.0 mM.

Bicuculline alone or in combination with GABA failed to affect the ERG. In the isolated frog retina 0.2 mM GABA depressed the b-wave. Picrotoxin reversed the b-wave amplitude depression of GABA (Urban et al., 1976). Using the isolated perfused bullfrog eye, Marchese & Friedman (1973b) demonstrated a diminution of b-wave amplitude when GABA in doses of  $10^{-6}$  to  $10^{-5}$ M were perfused through the eye via the ophthalmic artery. This effect was reversed by  $3.3 \times 10^{-7}$ M bicuculline. GABA at 0.1 to 10 mM infused into an open mudpuppy eyecup preparation caused a selective decrease of oscillatory potentials of the ERG within one minute. The b-wave unaltered at low concentrations diminished slightly at the higher concentrations (Wachtmeister & Dowling, 1978). Bonaventure et al., (1974) suggests that GABA acts as an inhibitory transmitter in the retina at a presynaptic site.

## 2. Glycine

Glycine is another depressant amino acid now considered to be a strong candidate as an inhibitory neurotransmitter in the central nervous system. Bruun & Ehinger (1972) reviewed the evidence for glycine's role as a transmitter and demonstrated that glycine is actively concentrated against a considerable gradient, i.e., there is an active uptake mechanism in the rabbit retina, similar to that in the spinal cord. This uptake mechanism is selective

for glycine and unaffected by other amino acids such as GABA,  $\alpha$ -alanine,  $\beta$ -alanine, aspartic acid, glutamic acid or lysine at concentrations 1000 times greater than glycine. Haloperidol has a specific inhibitory effect on the glycine uptake mechanism of the rabbit at concentrations as low as  $10^{-6}$ M. Tritiated glycine localizes in the inner plexiform layer and the nerve fiber layer of the human retina (Ehinger, 1972). There was a striking similarity in the distribution of glycine occurring in rabbit, rat and guinea pig retinae. Ehinger & Falck (1971), B. Ehinger (unpublished). Ames & Pollen (1969) found glycine inhibitory on the isolated rabbit retina ganglion cell at doses as high as those necessary to produce an inhibitory effect with GABA. Murakami *et al.*, (1972) report that glycine hyperpolarized the horizontal cells and blocked synaptic transmission. Starr (1975) reported that glycine in the *in situ* rabbit eye cup, caused a suppression of b-wave amplitude. He indicated that glycine behaved in a manner opposite to that of GABA (which enhanced b-wave amplitude) and like taurine, glycine was less effective than GABA. Korol & Owens (1974) injected rabbit eyes intravitreally and noted loss of oscillatory potentials one hour after injection. This inhibitory effect required 20 to 24 hours to return to control levels. Rabbits pre-treated with glycine were then challenged with intravitreal strychnine. At doses of 1 mg, the b-wave disappeared, 0.25

mg strychnine had no effect on the b-wave but 0.12 mg strychnine caused recovery of the oscillatory potentials.

Leuenberger et al., (1975) noted that the cytopathological effects produced by glycine in amacrine cells was reversible after 24 hours. Their autoradiographic study indicates that tritiated glycine had a non-specific effect, i.e., there was a general distribution of the label in the inner nuclear layer and inner plexiform layer. They suggest that the ERG effects seen above may be due to an overall somatic membrane action rather than as a neurotransmitter acting at a specific synapse.

### 3. Taurine

Taurine is present in the retina, in concentrations of about 10-14 mM/gram. (Pasantes-Morales et al., 1972a; Starr, 1973). Tritiated taurine applied to rat, cat, pigeon, rabbit and guinea pig retinas concentrate about the Müller fibers and photoreceptor cell. The retinal pigment epithelium of the cat and pigeon was also heavily labeled. The distribution of taurine in the inner plexiform layer of the pigeon suggests it is involved with synaptic activity there (Voaden et al., 1977). Pourcho (1977) using ( $^{35}\text{S}$ ) taurine reported that the outer nuclear layer, the inner nuclear layer and vitreal surface of Müller cells were the major sites of label concentration in the mouse retina. She suggests taurine is localized in the photoreceptors and



Müller cells. Taurine enters the neural retina from the blood stream through the retinal pigment epithelium (Young, 1969; Lake et al., 1977). Strychnine (0.05M) abolished the effects of taurine on the chicken ERG, Picrotoxin at doses of 0.0001, 0.005 and 0.01 M injected intravitreally did not alter the taurine suppression of b-wave amplitude (Bonaventure et al., 1974). A consistent reduction in b-wave amplitude of the rabbit eyecup preparation was reported by Starr (1975) at taurine concentrations of 0.1 mM and 1.0 mM. At 1.0 mM the b-wave was 64-79% of the control level ( $p < 0.01$ ). The observation by Hayes et al., (1975) that elimination of taurine from the diet causes degeneration of the photoreceptors may be significant in indicating the possibility of a more general functional role for taurine such as subserving some modulatory function of synaptic inhibition in the retina.

## ELECTROPHYSIOLOGY

Hartline (1938) and Granit (1955) were among the first physiologists to record the electrical responses from single populations of retinal neurons, a physiological technique analogous to that of the anatomists' Golgi method. It was virtually impossible to separate graded electrical responses of one cell from another because their methods were essentially extracellular. To record discrete cells it is necessary to record intracellularly. The high insulating properties of the cell membrane effectively isolates the cell from its neighbors electrically. Svaetichin (1953) was the first who successfully recorded intracellularly from cells in the retina. His work was not fully appreciated until much later because it was difficult at that time to understand the maintained hyperpolarization and only rarely depolarization responses he obtained to light stimulation in contrast to the spike action potentials that nonretinal physiologists obtained from their preparations. All work from the time of Adrian (1945) utilized the electrical responses of single neurons or muscle cells. Stimulation of these cells generated impulses rather than sustained responses. We now know that the initial physiological event in vertebrate vision is a hyperpolarization of photoreceptors

(PR's) from the work of Tomita (1976, who recorded from single PR's with ultrafine micro-electrodes and identified them by microinjection with Procion Yellow.

Recording from every retinal neuron, however, is still not enough to decipher the functional circuitry of the retina because many cells, though broadly classified as bipolar, horizontal, amacrine, or ganglion cells are among themselves anatomically and functionally quite different.... If must, of course, be understood that even when all the synapses leading up to the 10 or 20 unique varieties of ganglion cells which exist in most vertebrate retinas have been described and when something is known about the physiology of each particular cell in these circuits, we may not comprehend the precise role or roles of all the circuitry responsible for controlling the discharge of ganglion cells.... The retina is doing things to serve an extraordinary master deeper in the central nervous system and it is not always apparent to our own system of logic what sorts of operations must be performed. (Gouras, 1976).

Recording gross field potentials from the intact eye, one sees features not apparent from unit studies. Like the electroencephalogram, the electroretinogram represents the combined activities of large populations of activated neurons. The ERG represents the mass transient electrical responses of rods, cones, rod-retinal pigment epithelium interaction and inner nuclear layer activity. There is no discernible ganglion cell or optic nerve contribution to the ERG according to Tirala (1917). While many features of the various components of the ERG among different vertebrates are similar, the c-wave and standing potential differ markedly. In a comparative study, Kikawada (1968) reported on the variations in the corneoretinal standing potential in

response to light and dark adaptation of mammalia, aves, amphibia, reptilia and pisces. In man, a light peak (i.e., a sharp rise in the corneofundal potential following the d-wave of the ERG) occurs during light adaptation and a dark peak following dark adaptation. Similar variations of the standing potential (SP) occurred in other mammals such as the monkey, dog, cat, rabbit and guinea pig and also in the pigeon. This potential, termed the post-d-wave peak, is a positive variation of the SP. It occurs in mammals, birds and reptiles, but is absent in frogs, fish, newts and eels. No light peak or post-d-wave peak was ever observed among the amphibia. Täumer, et al., (1974) reported that in man subsequent to a stepped increase or decrease in luminance, a damped oscillation of the ocular dipole was evoked. This finding required sampling, for 10 seconds, of the electro-oculogram (EOG) of Tropicamide-treated volunteers every 1 to 2 minutes for periods up to 4 hours.

Lurie (1976) using very stable low drift dc recording equipment, studied the intact, circulated frog eye. His simultaneous recordings of the dc electroretinogram and single dimming fiber of the optic nerve (from class IV ganglion cells) indicate a close correlation between the activity of dimming fibers and the c-wave. He hypothesized that the slow transretinal current flow generated by means of an interaction between photoreceptors and pigment epithelium can

transmit information through the retina related to photoreceptor sensitivity, indicating a clear correlation between the c-wave voltage and the activity of optic nerve fibers. This fact, he suggests, might indicate another means by which information is transmitted to the nervous system. In his thesis (from which the above was abstracted), Lurie made preliminary observations of drug effects on retinal electrophysiology using the following pharmacological agents: acetazoleamide, strophantidin, ouabain, cyanide, azide and iodate. However, there was no attempt to assess the effects of putative neurotransmitters found in the eye or their antagonists.

#### The Electroretinogram

The electroretinogram (ERG) was described by Granit (1959) as a "polyphasic mass response with specific corneal positive deflections at the onset and cessation of illumination."

With a simple galvanometer, DuBois-Reymond (1849) discovered the existence of an electrical potential of several millivolts by attaching his electrodes to the cornea and optic nerve of the fish eye. This potential, he found, was positive in polarity at the cornea with respect to the back of the eye. Seventeen years later, Holmgren (1865-1866) confirmed the "current-at-rest" described by DuBois-Reymond in the frog eye. He noted that the eye produced a positive

deflection when exposed to light and another positive deflection when the light stimulus terminated. Dewar & McKendrick (1873a,b) independently discovered the same phenomenon and by 1876, Dewar extended his findings to include vertebrates of all classes. In 1877, Dewar described the ERG of the human eye.

In an attempt to eliminate the artifacts produced by injury potentials, muscle potentials and lens potentials, Kühne & Steiner (1880) isolated the retina from the intact frog eye and found the retina to be responsive while the sclera, choroid and pigment epithelium were entirely unresponsive to illumination. Gotch (1903) used the capillary electrometer, an advanced instrument in its time, to demonstrate the temporal characteristics of the ERG. Brück & Garten (1907) and Piper (1911) confirmed the earlier work of Dewar in a comparative study of the ERG's of a number of vertebrate eyes. Einthoven & Jolly (1908) studied the potentials of the frog eye with a directly-coupled string galvanometer, a more sensitive and responsive instrument. They attributed the origin of the components of the various waves to three substances contained within the retina. They termed the resultant potential evoked by light in order of occurrence, the A, B and C waves after the A, B and C substances. The d, which they attributed to a "darkening reaction of the first substance", or off-wave, was called

the A<sup>1</sup>-wave (Day, 1915, was responsible for the term d-wave). Figure 2 compares an ERG recorded by Einthoven & Jolly with a modern recording. Some features of the ERG are not seen in this figure due to the stimulus and recording parameters used.

In the modern version, the initial response to light, the a-wave is a corneal negative deflection followed by a positive b-wave which decays and is then followed by a somewhat later positive deflection, the c-wave. The stimulus used in both ERG's was too short in duration to demonstrate the d- or "off" potential which normally occurs as a positive going deflection. Chaffee et al., (1923) used the newly-developed vacuum tube amplifier (directly coupled) for more precise measurement of the "retinal action currents".

Tirala (1917) was able to show that various narcotics did not affect the ERG of an anesthetized animal but did cause a depression of the electrical activity of the ganglion cell layer of the retina, optic nerve and CNS. This supported an earlier hypothesis (Kühne & Steiner, 1880) that the ERG originated in the photoreceptor layer. Adrian & Matthews (1927) attributed the relatively-long but constant interval between the ERG and optic nerve potential (ONP) to conduction time.

Granit (1933) concluded that the origin of the ERG was more complex and involved other layers of the retina in

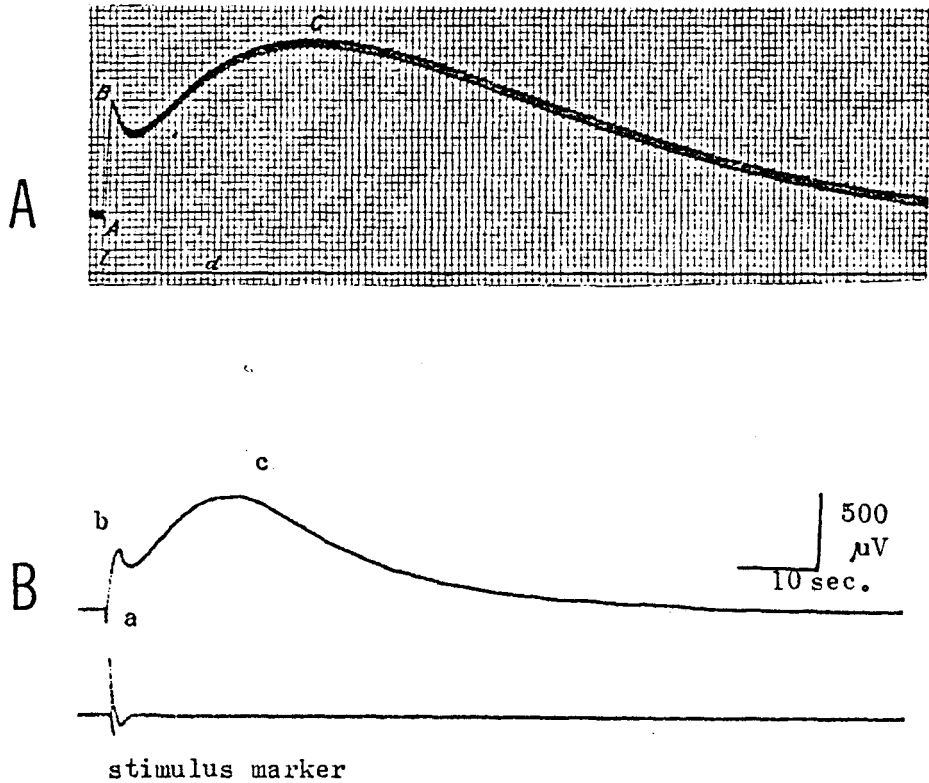

Figure 2 Comparison of ERGs recorded in the excised and isolated perfused frog eye.

- A. ERG recorded in 1908 by Einthoven & Jolly from the excised eye of a frog. Components are designated by the letters A, B and C. Calibration: Ordinate: 1mm = 10 microvolts; Abcissa: duration, 1 mm = 0.5 seconds. ERG evoked by green light of 0.01 seconds duration.
- B. ERG recorded about 70 years later using the intact, isolated perfused frog eye. Components are designated a, b and c-waves. Calibration: as indicated in Panel A. Lower trace: Stimulus marker for photostimulation by the discharge of a xenon flashtube. Duration: approximately 10 microseconds.



addition to the photoreceptors. He assumed that the various cellular components of the retina would respond differentially to chemical and physical intervention. He used the effects of ether narcosis and asphyxia on the eye to analyze the complex ERG response. The first response of the eye affected by ether was the disappearance of the c-wave, the faster waves, however, remained. Additional etherization caused the b-wave to disappear next. Both of these effects are reversible. Deeper anesthesia also abolished the a-wave, which generally did not recover. Since these phenomena had a regular sequence he considered that they were fundamental processes and he termed them PI, PII and PIII (c-wave, b-wave and a-wave, respectively). The complex waveform in the complete ERG, he states, is an algebraic sum of component processes of opposite signs. Armington states in his volume on the electroretinogram (1974), "Granit's (1933, 1963) component analysis is without doubt the most important yet made in electroretinography. Although it gives an oversimplified picture, it has retained descriptive value for over 40 years".

Granit (1935) distinguished two types of retinae - E-retinae and I-retinae - based on the reaction to intermittent light-stimulation upon the eyes of the frog, pigeon, owl, cat and rabbit. He suggested that the E-type retina was more typical of the rod-dominated eye of nocturnal

animals while the I-type is found among the cone-dominated eyes of diurnal species. EI (mixed) retinae, like those of the frog or owl, react when dark-adapted like E-retinae, while the I-type response appears when the eye is light-adapted. Granit's schematic description of E-and I-retinal responses is as follows: "The E-retina flickers with volleys of excitation, the I-retina with volleys of inhibition interrupting the 'rebound' of impulses at 'off'".

Motokawa & Mita (1942) discovered a wavelet in the human ERG which they called the x-wave. It is a fast initial positive response following the a-wave, and preceding the b-wave. Schubert & Bornschein (1952) obtained x-waves in the ERG's of normal, hemeralopic (rod-blind) and deuteranopic (green-blind) eyes but not in protanopes (red-blind). Armington (1952) studied the action spectrum of the x-wave and found it displayed greater sensitivity to red light. These data suggest that the x-wave (a fast b-wave) elicited from cone-containing retinas most likely originates from red sensitive cones.

Insight into retinal processing of light information was derived from studies of insect eyes. Their retinae yield simpler responses to light. In a novel and very useful way, layers could be removed leaving the remaining structures in a functional state allowing the investigator to explore the origin of some of the responses.

Two distinct types of ERG's were described for the invertebrate eye by Autrum (1951). In Calliphora, light generates a rapid positive wave. When the light is terminated, a fast negative wave occurs. The ERG can respond and follow flickering light at a rate of 200-300/second. In Tachines, however, light produces a sustained negative wave. Its flicker response is only 20-30/second. Removal of the cells near the photoreceptors in Calliphora reduced flicker fusion about 1/3. With only a pure receptor layer remaining, flicker responses was 10/second and its wave form was monophasic like that of Tachines. This suggests that ganglion cells are responsible for fast flicker responses. Vertebrate retinae do not lend themselves to this technique because of very small cell size. However, the ability to record from one neuron in a population of many was coming into vogue. Hartline (1938) used this technique and successfully recorded in response to illumination impulses from the optic nerve of Pecten as well as from single fibers of the vertebrate eye.

Localization of the ERG components by use of micro-electrodes recording at different depths of the retina was first studied by Tomita (1950) on an excised frog eyecup preparation. He found a normal ERG at the vitreal surface of the retina but when the electrode was advanced further there was a gradual inversion of polarity of the a-, b- and d-

waves. This inversion was complete at the outer plexiform layer but the c-wave retained the same polarity throughout. He found that no c-wave could be obtained in retinas detached from their pigment epithelium. Similar results were reported by Brindley (1956c,1958) on frogs and by Brown & Weisel (1961a & b) in cats.

#### The c-wave

Noell (1953) used iodoacetic acid (IAA), sodium azide and sodium iodate to produce structural changes in the retina that could be correlated to changes in ERG components and optic nerve potentials. Iodoacetic acid affects cellular metabolism and has a selective action on photoreceptor cells. A single injection reversibly abolishes electrical responses. Cell death occurs within a few hours after a second dose when drug elimination is retarded. After IAA, the photoreceptors are destroyed but the inner layers and pigment epithelium of the retina remains intact and functional. Injection of 5% sodium iodate selectively destroys the pigment epithelium cells causing the disappearance of the c-wave. Sodium azide produces a sudden increase of the standing potential of the eye and concomitantly enhances the c-wave response to illumination. Noell found that azide enhancement of the c-wave could be blocked by sodium iodate but not with iodoacetic acid. Thus, the selective destruction of the pigment epithelium by sodium iodate suggested

to Noell that the c-wave originates in the pigment epithelium. Brindley (1956a) discovered a barrier of high electrical impedance which occurred when the recording microelectrode is advanced beyond the position of the inverted a-wave. He termed it the "R"-membrane (tentatively) i.e., the external limiting membrane and surface membrane of the rods and cones. Brown & Weisel (1961) recorded the local electroretinogram (LERG) in the cat eye. Components ordinarily seen in the diffuse ERG with the exception of the c-wave were inverted in polarity. When the electrode penetrated Bruch's membrane (which contains the basement membrane of the pigment epithelium), the c-wave disappeared. This evidence strongly supports the hypothesis that the site of origin of the c-wave (PI of Granit) is the pigment epithelium. Intracellular recordings from intact pigment epithelial cells of the cat have characteristics very much like those of the c-wave (Steinberg et al., 1970). Using potassium-specific microelectrodes, Oakley & Green (1976) measured light-induced changes in potassium ion concentration of the frog eyecup preparation. This they termed the potassioretinogram (KRG). The KRG has the same temporal characteristics as the c-wave of the ERG including response to intensity changes, duration and chromaticity. The KRG has a rhodopsin action spectrum indicating that the rhodopsin rods of the frog interacting with the ROS are responsible

for this response. The mechanism proposed is that the RPE cells hyperpolarize in response to the decrease of potassium ion concentration surrounding the photoreceptors. The light-evoked decrease in potassium ion concentration in the receptor layer supports Steinberg & Miller's (1973) suggestion that a decrease in potassium ions surrounding the apical membranes of the retinal pigment epithelial cells generates the c-wave, "although the c-wave arises behind the retina, it is coupled in some fairly direct way to retinal action. It responds in some fairly direct way to retinal signals" (Armington, 1974).

#### The b-wave

Early extracellular microelectrode exploration of the retina (Tomita, 1950; Ottoson & Svaetichin, 1973) localized the origin of the b-wave (PII) to the bipolar cell layer. Using the extracellular technique the potential size is a function of the distance of the electrode from the source. The closer to the source the larger the potential. Brown (1968), using this method, suggested that the source of the b-wave lies in the inner nuclear layer. Miller & Dowling (1970), studying the large retinal cells of the mudpuppy (Necturus), obtained intracellular recordings of light evoked responses from cells verified by intracellular staining with "procion yellow" and concluded that the b-wave originates in the Muller cells which are glial in

nature. Tomita (1976), however, questions the conclusion of Miller & Dowling that the b-wave originates in the Müller cells in that the diffusion of potassium proceeds at an apparently slower rate than the rapid depolarization represented by the b-wave. It has been suggested by others that the light-induced activity in distal retinal neurons causes a local depolarizing potential in Müller cells possibly resulting from changes in extracellular potassium ion concentration (Miller, 1973; Karwaski & Proenza, 1977).

#### The a-wave

Brown & Weisel (1961) found that the amplitude of the a-wave of the cat retina was largest when microelectrodes were placed in the photoreceptor-pigment epithelium layer and was undiminished by local anesthetic. Various investigators have recorded ERGs from isolated retina preparations devoid of retinal pigment epithelium (Ottoson & Svaetichin, 1953; Brindley, 1956a; Tomita & Tarihami, 1956). This excludes the pigment epithelium as the site of origin of the a-wave. The outer segments of the photoreceptors appear to be the most likely source of the a-wave. Selective clamping of the primate central retinal circulation abolishes ERG components in the inner nuclear layer. When this was done one component remained which could be identified as the leading edge of the a-wave of the normal ERG (it should be noted that the choroidal circulation

which supplies the photoreceptors was not changed). This response was termed the late receptor potential (late RP, i.e. the PIII component of Granit). (Brown et al., 1965). Rodieck & Ford (1969) found that clamping the retinal circulation of the cat produced similar results. Murakami & Kaneko (1966), using isolated frog and turtle retinae, found that the PIII in these vertebrates had a dual origin which they identified as the proximal and distal PIII. The latency of response of the "proximal PIII" (identified by their technique as originating in structures more vitread than the photoreceptor) was longer than the latency of the "distal PIII" (which originates in the photoreceptors). This response does not occur in mammals. Brown et al., (1965) obtained pure cone responses from the fovea of the cynomolgus monkey (Maccaca irus) and pure rod responses from the all-rod retina of the night monkey (Aotes trivergatus). Comparison of these responses has shown that the decay of the cone signal occurs rapidly while that of the rods very slowly. Gouras (1965) used stimuli which selectively-excited the rods or cones of the rhesus monkey. When rods alone were stimulated the latency of response of the ganglion cells was considerably longer than when cones were excited. In a later report, Gouras (1967) stated that with all patterns of stimulation and adaptation threshold, rod signals arrive at the ganglion cells more than 50 milli-



seconds and threshold cone signals less than 50 milliseconds after the light stimulus.

In addition to the aforementioned late RP component of the a-wave reported by Brown et al., (1965) Brown & Murakami (1964) identified another biphasic receptor potential of the monkey retina with an extremely short latency. This response was elicited by a very brief (20  $\mu$  sec.) flash of light of very high intensity (Xenon flash tube of Grass photostimulator, Model PS-2). This response, however, could not be elicited with a tungsten light source. They named it the early receptor potential (ERP). Goldstein (1967) recorded the ERP of the isolated frog retina in response to light of different wavelengths. He found the spectral sensitivity of the ERP to peak at about 560-590 nm which suggests that the ERP of Rana pipiens is generated by cone pigments and not rods. Cone (1964) has shown that the amplitude of the negative phase of the ERP of the albino rat (all rod retina) is directly proportional to the percent of rhodopsin bleached by a short flash. Thus, the ERP seems to be a signal related to visual pigment kinetics.

#### The d-wave

The origin of the d-wave has received relatively little attention in the literature. Einthoven & Jolly (1908) attributed the  $A^1$  wave (d-wave) to a "darkening reaction of the first substance". Granit (1933) in his analysis noted

that the d-wave remains upon removal of PI (c-wave) and PII (b-wave) components. The only component necessary for the d-wave to appear is the negative PIII (a-wave). Further, the retinal off-effect (d-wave) is definitely connected with a discharge of impulses through the nerve. Brown et al., (1965) reported that the amplitude of the d-wave onset phase varies with that of the a-wave while its falling phase varies similarly to that of the b-wave. It therefore results from two different components of opposite polarity. In the monkey retina, the onset phase of the d-wave seems to originate from the decay of the cone late-RP, while the falling phase can be attributed to a decay of the d.c. component from the inner nuclear layer.

#### The e-wave (delayed off response)

The e-wave was discovered in the isolated frog retina by Sickel & Crescitelli (1967). It is an ERG potential having a lower threshold than the d-wave and its latent period or implicit-time increases as stimulus intensity augments. The e-wave occurs in the dark-adapted retina but can also be elicited in a retina subjected to a 95% bleach of rhodopsin (isolated retinae cannot regenerate rhodopsin in the absence of the RPE) (Ewald & Kühne, 1877, 1878; Baumann, 1965). Simultaneous spike discharges associated with the e-wave can be seen in the isolated retina preparation. A similar long-delayed response has been reported by

Pickering & Varju (1967). It was noted that bursts of ganglion cell activity occur after light stimulation ceases. Increased stimulus intensity produced a longer latency of the delayed response. The delayed-off response studied by Pickering & Varju (1969) was influenced by background illumination and the degree of dark-adaptation. Latency increased as background illumination decreased and as dark-adaptation increased (Pickering, 1968). These results suggest that the interaction of converging excitatory and inhibitory retinal processes produce the delayed response. The similar properties of the e-wave (Crescitelli & Sickel, 1968) and the delayed off-response in ganglion cells (Pickering & Varju, 1969) suggest they are manifestations of the same process.

#### Oscillatory Potentials

Granit & Munsterhjelm (1937) reported the presence of multiple b-waves which could be elicited in excised frog eyes with a single, weak monochromatic stimulus (470 nm). They termed this phenomenon "the switchboard effect". At higher intensities of stimulation only a single b-wave was obtained. Similar oscillations occurring during the rising phase of the b-wave were reported in the pigeon, turtle and rabbit by Noell (1951). The term "oscillatory potential" was given by Yonemura, Masuda & Hatta (1963). They reported the occurrence of oscillatory potentials (OPs) in a

variety of vertebrate species. Granit (1947) claimed that the oscillatory wavelets were due to the algebraic summation of various processes each having its own response latency and amplitude. Brown et al., (1965) recorded oscillations from the peripheral retina and fovea of the monkey. In the peripheral retina the oscillations begin on the rising phase of the b-wave and are rather large. In the fovea, the oscillations are smaller. When the retinal circulation was clamped the oscillations and the b-wave disappeared leaving only the receptor response. This suggests that the OPs probably do not originate from receptors or cells which generate S-potentials. Brindley (1956c) recorded oscillatory responses in the frog retina and since there was no reversal of sign over the ranged depths he examined, he concluded that they could not originate from radially-oriented structures (e.g., rods and cones are radially-oriented and act as radial dipoles, i.e. their responses are negative at their posterior and positive at their anterior poles). He hypothesized that the oscillations were due to tangentially-oriented structures in the inner nuclear layer of the retina, Yonemura & Hatta (1966) also found maximum OPs at the level of the inner plexiform layer. Kaneko (1970) identified oscillatory potentials in the bipolar cells of the goldfish retina. Of the multiple OPs found in pigeon, chicken and monkey by Ogden & Wylie

(1971) and Ogden (1973), the first three OPs were localized in the inner plexiform layer, suggesting that the terminals of bipolars, the processes of amacrine and the dendrites of ganglion cells could all participate in the generation of these potentials. Ogden found that wavelets in the optic tract could be dissociated from those of the intraretinal ERG by intracarotid injections of barbiturate together with the differential effects of adapting lights. Ganglion cell responses blocked by tetrodotoxin did not affect the OPs of the ERG. Korol et al., (1975) demonstrated that in response to injections of glycine the OPs disappeared from the ERG and morphological changes occurred in the amacrine cells in the rabbit retina. Wachtmeister & Dowling (1978) reported that the OPs of the mudpuppy retina were selectively depressed by application of GABA, glycine, glutamate and dopamine. They proposed that the OPs represent inhibitory feedback loops within the retina.

#### The Standing Potential (SP)

The standing potential was first described by DuBois-Reymond in 1849 who found that the SP was positive in polarity at the cornea with respect to the posterior portion of the eye. Holmgren (1879,1880) was the first to map the spatial distribution of the potential about the eye and noted that the largest potential was measured between the opposite poles. He observed that the SP was not constant

but drifts with time. Himstedt & Nagel (1902) found that as the resting potential swung upward from the baseline, ERGs elicited became larger in amplitude. Dewar & McKendrick (1876) discovered surprisingly that the polarity of the invertebrate eye was opposite that found in vertebrates. However, Toyoda et al., (1969) found that only the receptor cells of invertebrates are reversed in sign.

The SP of the excised frog eye has been reported to be 6 to 10 mV (Kohlrausch, 1931; Ottoson & Svaetichin, 1952; Brindley, 1956d; Dzendolet, 1960b). A SP of 10 to 30 mV with extremes of 2 to 41 mV were subsequently reported by Brindley (1956a). Brindley (1956d) demonstrated that the lens contributes to the SP. The retinal contribution when recorded by an advancing electrode is the sum of potential steps which occur in several layers (Tomita, 1950; Brindley 1956a). Ottoson & Svaetichin (1952) did not find the same pattern. Brindley (1956a) using the advancing electrode technique encountered a membrane of high resistance which he named the "R membrane". Gurian & Riggs (1960) determined that all electrical characteristics of the in vivo frog eye except the SP were indistinguishable from those reported by Brindley (1956a) and Svaetichin (1956) in the in vivo preparation. In the in vivo preparation the SP is apparently short-circuited by surrounding tissue.

### The Compound Potential of the Optic Nerve

The fibers of the optic nerve originate from ganglion cells in the retina and terminate in the lateral geniculate nucleus (LGN). The axons originating in the LGN extend through the optic radiation to their terminus in the visual cortex. Recording from individual ganglion cells reflects no more than the activity of that individual neuron. Ideally, it would be valuable to record the simultaneous activity of all the retinal ganglion cells individually but this is an impossible task since over one third of all the sensory neurons entering or leaving the CNS are located in the optic nerve (Pirie & Van Heyningen, 1956). However, after the onset and cessation of a visual stimulus the response pattern of ganglion cells is such that synchronous activity is likely to occur and the activity resulting from these transients overrides that of the other neurons in recordings made from the whole optic nerve (Bartley & Bishop, 1942; Adrian, 1946; Granit, 1947; Noell & Chin, 1950). The response obtained from gross optic nerve recordings assumes the complex shape of the compound action potential owing to variations in nerve fiber diameters (Gasser & Erlanger, 1927; Gasser, 1933). The optic nerve responds to diffuse light stimulation of the retina with remarkable synchrony at very exact times after "on" and "off" stimulation. Lederman & Noell (1969) found that all fast-conducting axons or a

fraction of this group were refractory for 5 to 20 m sec. after an electrical pulse was applied directly to the nerve. Oscillations in the optic nerve response correlates with groups of discharges at the single unit level (Doty & Kimura, 1963; Crapper & Noell, 1963). Using transretinal stimulation, (i.e., cathodal and anodal pulses applied between the vitreous body and the exterior of the eye), Lederman & Noell (1969) analyzed the inhibitory and excitatory phase of the stimulated retina and were able to differentiate between the fast (F) and slow (S) fiber systems and their corresponding retinal cell population. Outward (anodal) current similar to the "on" of diffuse light stimulation elicits a period of strong inhibition; while inward (cathodal) current like the "off" of diffuse light stimulation is excitatory to F-cells. When these systems are stimulated there is a rhythmical alteration in the response so that synchronous bursts of firing are separated by silent periods of 25 to 40 m sec. It was concluded that the rhythmic alteration seen was the result of interactions of excitatory and inhibitory systems. This suggests that a correlation in the action of excitatory and inhibitory neurotransmitters probably occurs at the retinal level. In gross recording of optic nerve responses, variations in amplitude occur in the isolated rabbit retina (Ames & Gurian, 1963), the isolated perfused feline eye (Niemeyer,



1975, 1976, 1977) and in in vivo preparations of rabbit, monkey and cat eye (Noell, 1953). These variations depend on progressive changes in the crushed end of the nerve, size and tip of the electrode, its position on the nerve and changes in the resistance of the nerve surface resulting from pooling of the surrounding fluid. However, the mere presence of optic nerve responses is already a good index of the viability of the retinal ganglion cells.

Cohen (1970) studied the activity of glial cells located in the optic nerve of Necturus. He used a method of current injection to selectively alter the membrane potential of glial cells without affecting that of the axons. Simultaneously, he recorded intracellularly from glial cells and by the sucrose gap method. When compared to the intracellular responses the sucrose gap recordings remained a constant fraction (40%) of the intracellular recordings at all intensities of stimulation used. His findings suggest that in surface recordings from the optic nerve the glial contribution is relatively large and is equivalent to the contribution from the neuronal membrane. Since glial cells are electrically-coupled to each other, they behave like a single "core" conductor. The low resistance pathway between cells is probably due to the "tight-junctions" which appear between the glial cell membranes. The resting potentials of glial cells are high

and they are sensitive to changes in  $K_o$ . They respond to externally-applied potassium ions by a slow depolarization, a response which also occurs during neuronal activity (Grossman & Hampton, 1968; Karahashi & Goldring, 1966; Kuffler et al., 1966; Orkand et al., 1966) because membrane potential changes run almost parallel to d.c. shifts in a variety of experimental situations and the membrane potential fluctuations of glial cells are closely-related to changes in activity of adherent neuronal structures. D.c. recordings would reflect neuronal excitation processes even if the steady potential is generated in part by glial membranes.

### Pharmacology of Retinal Blood Vessels

Blood flow in the retina can be measured in a number of ways: (1) by fluorescein angiography (Bullpitt & Dollery, 1971), (2) labeled microspheres (Alm, 1972) and (3) by quantifying close arterial oxygen tension (Alm & Bill, 1972; Tsacopoulos et al., 1973). With the latter technique it is assumed that the  $pO_2$  close to the retina reflects the oxygen tension within the retina. Vitreous oxygen consumption is considered negligible and changes in  $pO_2$  parallel blood flow changes, provided that arterial  $pO_2$  and  $O$  consumption of the retina are constant. Using this technique, Alm (1972) was unable to demonstrate any flow changes in retinal arterioles after the administration of

a variety of vasoactive drugs; viz., angiotensin, dihydroergotamine, histamine, isoproterenol, nicotinic acid, nor-epinephrine and xanthinol niacinate. Only the highly lipid soluble papaverine consistently augmented retinal blood flow.

#### Pharmacology of Choroidal Blood Vessels

Choroidal blood vessels in contrast with retinal blood vessels are vasoactive but not autoregulatory. They respond to sympathetic stimulation by vasoconstrictors (Alm & Bill, 1973) and appear to be alpha adrenergic in nature (Chandra & Friedman, 1972). In monkey facial nerve (Ruskell, 1971) the presence of cholinergic innervation to choroidal vessels together with the vasodilatatory response of choroidal vessels to acetylcholine (Chandra & Friedman, 1972) would suggest that the parasympathetic nervous system also participates in the regulation of choroidal blood flow.

#### Blood Flow Regulation in the Eye

Bill (1975) has defined the perfusion pressure of the eye as "the difference between arterial blood pressure in the small arteries entering the eye and the intraocular pressure". It can be reduced by augmenting intraocular pressure or by reducing blood pressure.

## METHODS

### Experimental Conditions

#### A. Animals & Environmental Conditions

Frogs: Large bullfrogs, Rana catesbeiana, and large leopard frogs, Rana pipiens, of either sex are used in these experiments. After receipt from the supplier (Nasco, Fort Atkinson, Wisconsin) they are maintained for a period of at least two weeks under fluorescent lamps (Vitalite, Duro Test Corporation, with a spectrum resembling daylight, i.e., 5400°K) on a regimen of 12 hours of light and 12 hours of dark each day at an average room temperature of  $22 \pm 1.0^{\circ}\text{C}$ , in tanks containing fresh water as well as dry areas. Tetracycline HCl (Polyotic<sup>R</sup>) dissolved in distilled water was administered per os twice a day at a dose of 5 mg/0.2 ml water/30 g of frog for a period of one week as a precaution because it is often difficult to obtain frogs in a healthy state. The frogs were allowed to recover and a minimum of three weeks was used to assure that the frogs were actually free of disease. According to Gibbs et al., (1966), the usual cause of high and rapid mortality are the combined effects of malnutrition and bacterial infection. The bacterial agents include Aeromonas hydrophilia (responsible for red-leg), Bacterium

alcaligenes, Citrobacter freundii and Staphylococcus epidermis. The slow growing Mimeae were also implicated. The treatment described above was R. pipiens but the authors state. and our results confirm, that the treatment has been used successfully with R. catesbeiana by increasing the dosage in proportion to the greater body weight. Gibbs et al., (1966) supplemented incandescent light with a period of daily exposure to UV light with sun lamps (GE275 watt 125V 60cps). "Vitalite" fluorescent lamps which, in addition, produce 365 nm (near UV) irradiation provide sufficient ultraviolet to maintain the animals in a healthy state.

The question of maintenance temperature was reviewed by Nace (1976).

Whereas mammals and birds are endothermal - they generate their own heat - amphibians are ectothermic - they maintain the stability of their body temperature by using heat from the environment. In natural habitats they control their temperature by selecting sun, shade or hidden positions. If amphibian species are not allowed to regulate body temperature by these methods in the laboratory, they may be stressed and become diseased, unless the temperature of their quarters is regulated.

Amphibians were formerly thought to be poikilothermic - having body temperatures which adjusted to environmental temperature, and it was thought that environmental temperature control was not important for these species. Current research indicates that temperature control is very important for proper maintenance of amphibians.

## B. Operative Procedures

The frogs are placed in a large light-tight container in the animal room and brought to the laboratory. Under low level illumination a frog is double-pithed and an eye is enucleated. The procedure begins with excision of the nictitating membrane. The upper lid is removed exposing the entire orbit. Gentle traction is applied to the eye by clamping the upper lid from behind with a mouse-tooth curved forceps reflecting the cut end. Blunt dissection using a small round-tipped curved scissors frees the eye from its attachment to the socket. The scissors is then directed toward the optic foramen to cut the optic nerve, ophthalmic artery and annulus of extraocular muscles. The eye is placed upon a small plastic dish containing a coiled cotton rope saturated with an oxygenated physiological salt solution. The remnant of the eyelid is severed from the eye by circumlimbal excision and the dish with the eye is placed upon the stage of the dissecting microscope. The cut end of the artery is located and freed from adherent connective tissue. A cannula of tapered No. 50 polyethylene tubing (method of Brooks & Muirhead, 1972) is inserted in the severed end and fixed there by means of a ligature of 6-0 surgical silk. The eye is perfused immediately with a modified Sickel's physiological salt solution (cf Appendix B) under pressure provided by a gravity system.

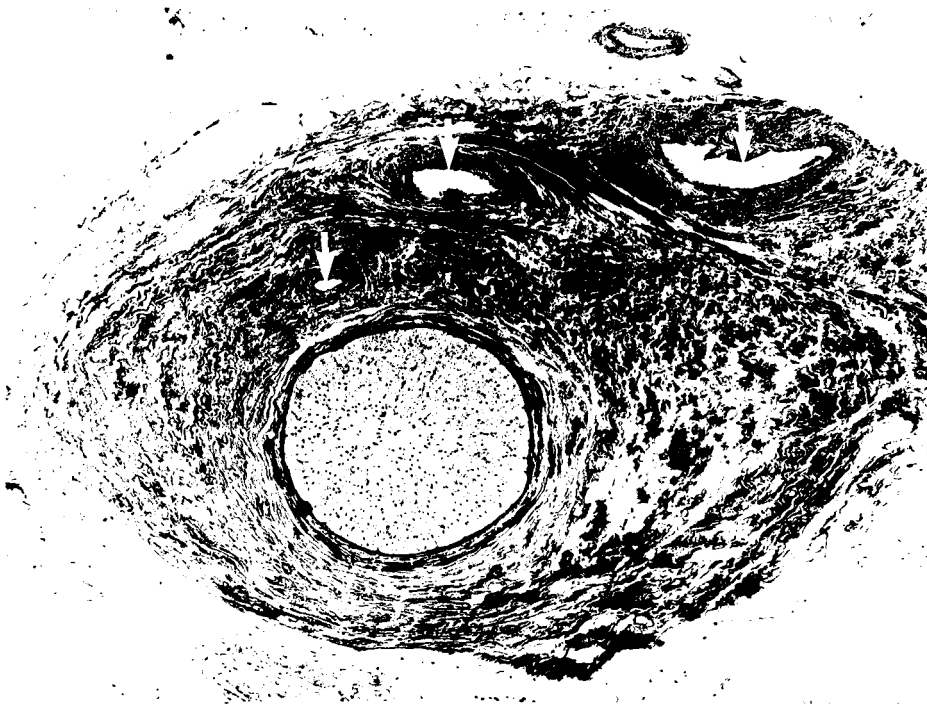

Figure 3      Cross-section of the frog  
                  optic nerve demonstrating its  
                  vascular supply

Arrows indicate some of the fine branches of the ophthalmic artery that nourish the optic nerve. The specimen is from an eye perfused with Sickel's medium.

NOTE: RBCs are absent in the vascular lumen.

Magnification 43X

The ophthalmic artery close to the eye sends off fine branches to the distal part of the optic nerve, forming a vascular network in the arachnoid layer (see Figure 3). Adherent tissues and extraocular muscles are dissected away under the microscope using care to avoid damaging and/or severing the ventral branch of the ophthalmic artery. This branch of the artery (Figure 4) runs forward to the ciliary region where it enters the eye and internally gives off two branches which run circumferentially around the ciliary body as an arterial circle. From this branch the superficial arteries of the iris emerge, then the ophthalmic artery turns backwards on itself as the "hyaloid artery" further dividing into the nasal and temporal branches, which then form an incomplete ring around the ora-serrata. Additional branches run posteriorly to form the membrana vasculosa retinae. Most, if not all, of the nutrition of the frog retina is supplied by these blood vessels. A branch of the posterior ciliary artery on the nasal side closely associated with the optic nerve is easily spared during the dissection procedure. However, the temporal posterior ciliary artery (Figure 3) which is embedded in the extraocular muscles and is normally invisible in the media-perfused eye, is invariably cut during the procedure. These branches, the nasal and temporal, supply the choriocapillaris. Ideally, the temporal branch should remain intact for optimum results but the use of 100% oxygen and an



SUPERIOR BULBAR VEIN

NASAL BRANCH  
of

POSTERIOR CILIARY ARTERY

OPTIC NERVE

TEMPORAL BRANCH  
of

POSTERIOR CILIARY ARTERY

OPHTHALMIC ARTERY

VENTRAL BRANCH  
of

OPHTHALMIC ARTERY

REGION of FETAL FISSURE

RETRACTOR FOR BULBI MUSCLE REMNANT

VENTRAL BULBAR VEIN

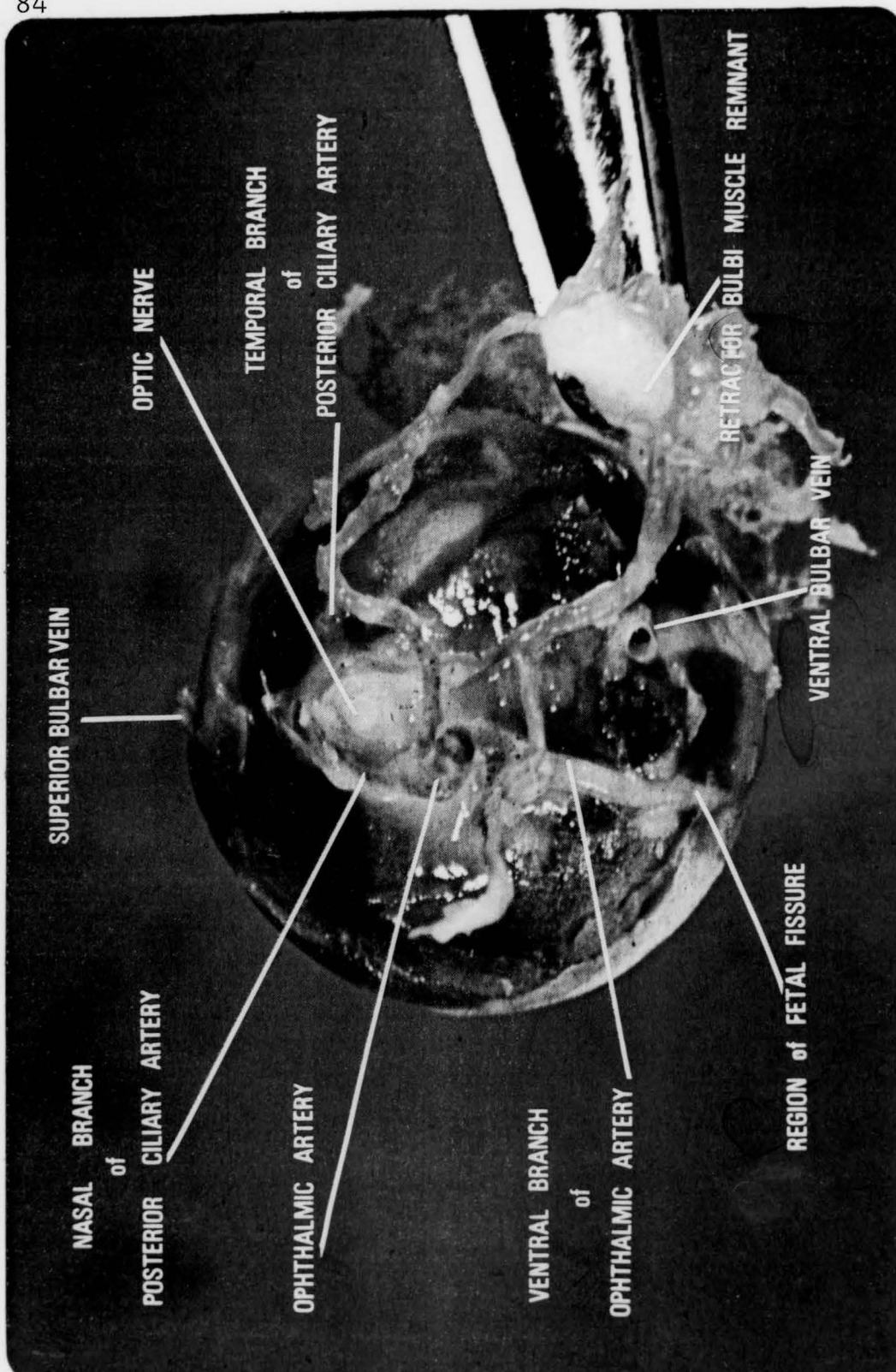

Figure 4 External vascular anatomy of the frog eye

adequate flow rate through the eye seems to be effective. Early experiments were carried out using No. 10 polyethylene tubing with increased perfusion pressure. It was found that the preparations did not last sufficiently long because even with increased pressure the bore of the No. 10 tubing was too small to provide adequate flow rates resulting in poor oxygenation. Then the system was changed to No. 50 tubing and 2% fetal calf serum was added to Sickel's physiological salt solution, the preparation remained stable and gave good results for the duration of the experimental procedure which could last for hours.

Two methods of supplying adequate flow rates were used: (1) Perfusion maintained at constant pressure - 25-45 mm Hg, i.e., to mimic frog arterial pressure, and (2) the use of a perfusion pump to maintain a constant flow rate. Using the former, agents which are vasoactive modified the results when vasoconstriction or vasodilatation occurred. The latter method overcame the resistance of the blood vessels and the electrophysiological events reflected neuroactive not vasoactive events.

Cats: Preliminary studies were performed in mature cats of either sex, obtained from our Animal Care Unit. They were anesthetized with  $\alpha$ -chloralose (60-70mg/kg) and sodium pentobarbital (Nembutal<sup>R</sup>) 50mg/kg, IP. Enucleation of the cat eye was performed in a manner similar to that

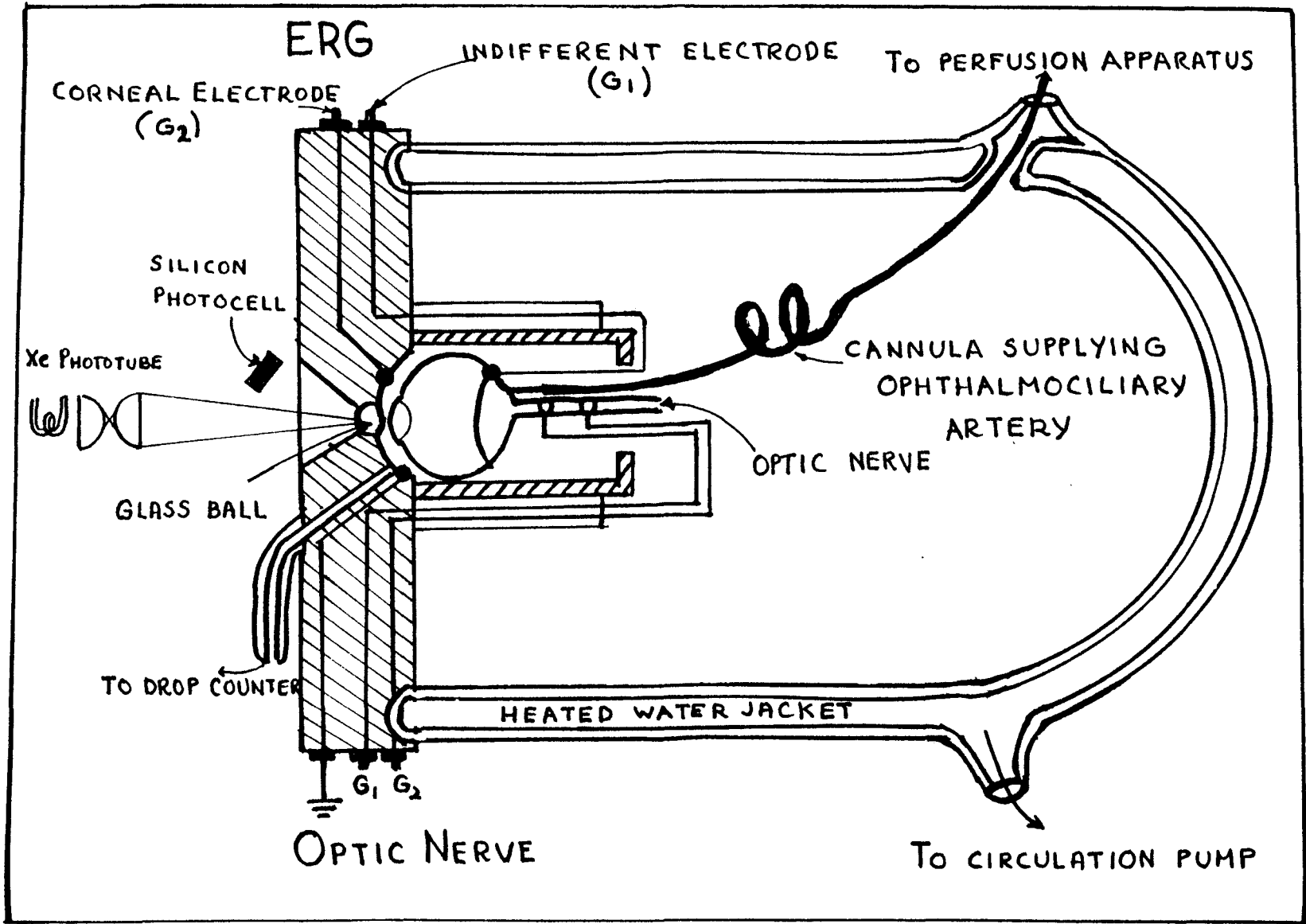

Figure 5      Schematic diagram of heated  
                 perfusion chamber for cat  
                 isolated perfused eye

The circular anterior wall of the chamber measures 1.2 cm X 8.4 cm. The heated water jacket has a circular internal cross-section of 5 cm and a depth of 7.5 cm (Volume 100 mls).

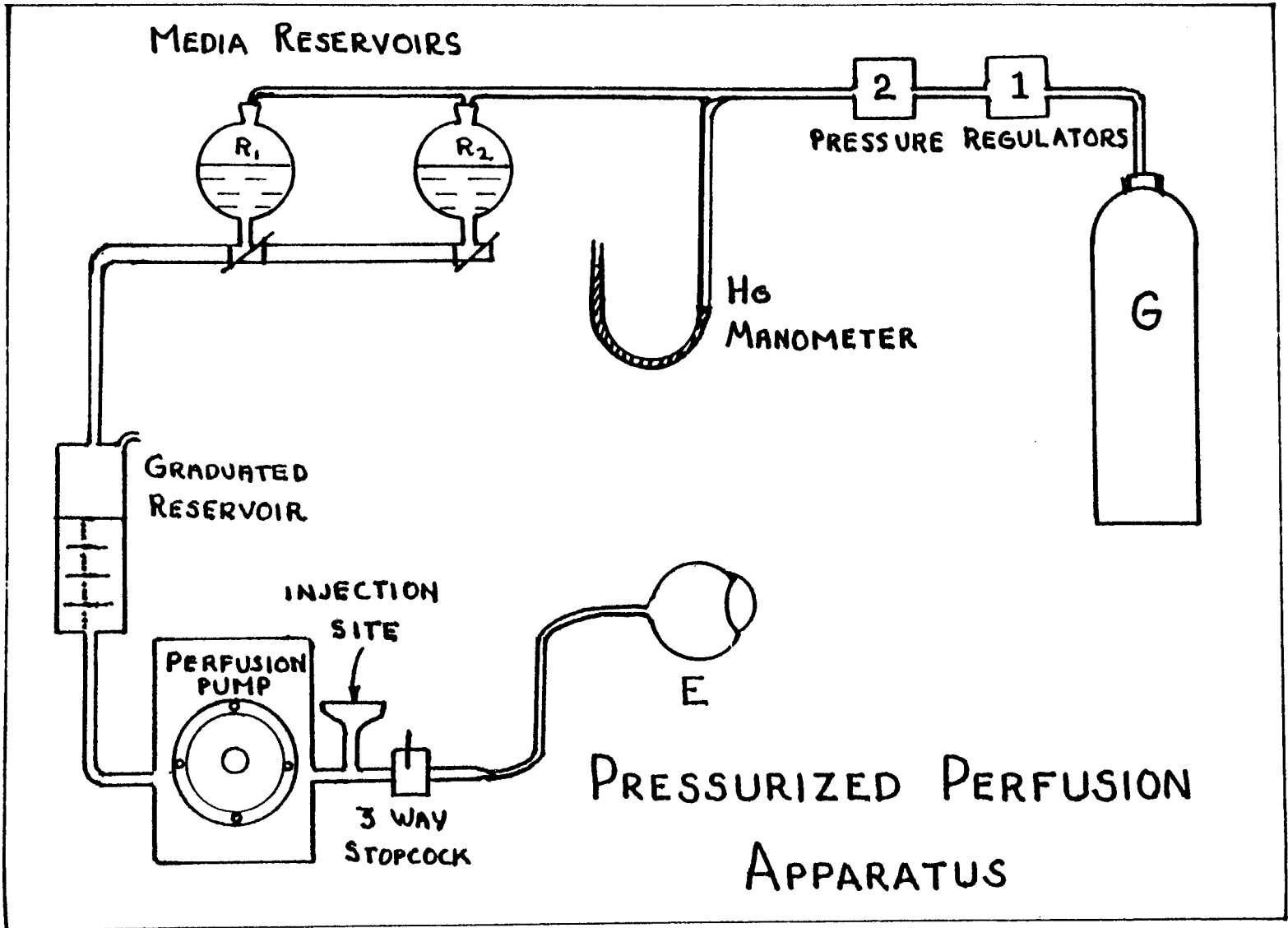

Figure 6 Pressurized perfusion apparatus

G-pressurized tank containing oxygenating gas mixture (see text). 1 & 2 state pressure regulators for constant pressure delivery;  $R_1$  &  $R_2$  pressurized media reservoirs; graduated reservoir for delivery of calibrated amounts of drug; perfusion pump for delivery of constant volume; rubber dam; injection site for retrograde injection of drugs; E-isolated eye.

the cornea. This served as the active electrode. Another chlorided silver wire contacting the rear of the bulb served as the indifferent electrode, while a third chlorided wire embedded in the bottom of the clear plastic cradle became the ground electrode.

A 5 mm hole was drilled into the center of the front piece and a 5 mm glass bead was cemented in place. A collimated beam of light was focused on the glass bulb in order to illuminate a large portion of the retina directly. A hole, drilled in the bottom of the cradle, at an angle directed toward the front piece led off the perfusate after it drained from the ocular veins. The entire isolated perfused eye holder assembly was mounted in a glass, water-jacketed tissue bath which served to keep the eye at the appropriate temperature (37°C). The electrodes used for the optic nerve of the cat eye were two fine, chlorided silver wires separated by several millimeters wrapped around the optic nerve stump. Care was taken to avoid damaging the vascular net surrounding the optic nerve near its exit from the eye and its tied, cut end (Wong & Macri, 1964). The perfusal delivery system consisted of two 500 ml glass leveling bulbs, sealed at the top with rubber stoppers and connected in parallel with a mercury manometer which was fed from a two-stage pressure regulator from the O<sub>2</sub> mixture tank used (Figure 6). At the opposite end of the bulbs



three-way control valves permitted the flow via tygon tubing from one or the other 500 ml bulb supply to the perfusion (#10 polyethylene) cannula. The perfusion pressure used for the cats eye was 140 mmHg and for the frog eye, 25-40 mmHg. These values were selected from the comparative blood pressure charts of the FASEB Biological Handbook Series, Biology Data Book. Drugs were administered by reverse injection into the tygon tubing, momentarily interrupting flow to the eye either through the injection site of the tubing or through the three-way stop cock joining the tubing to the perfusion cannula.

Perfusion rate was determined by counting drops per unit time. They seemed to be in agreement with the perfusion rates reported by Gouras & Hoff, viz., 7 drops per minute. Stimulation of field potentials was achieved with flashes of light delivered initially by a modified A.E.L. photostimulator and later by a General Radio Strobotac photostimulator. The power input to the A.E.L. unit was 5.64 Joules delivered into a G.E. #FT98 xenon flashtube, duration approximately 700 $\mu$ /sec. The G. R. Strobotac specifications are: peak light intensity at high, medium and low intensity ranges = 0.6, 3.5 and 11 million beam candles,  $6 \times 10^5$ ,  $3.5 \times 10^6$  and  $11 \times 10^6$  lux @ 1 meter distance at the center of the beam. Duration = 0.8, 1.2 and 3  $\mu$ s for high, medium, low @ 1/3 peak intensity (reflector beam

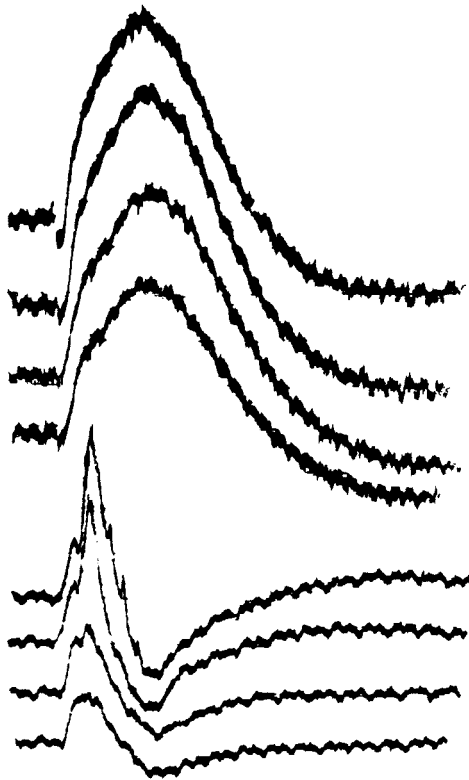

Figure 7      Responses of the isolated  
perfused cat eye to xenon  
flashes during dark-adaptation

Upper traces: a family of b-waves in ascending order.

Lower traces: a family of optic nerve potentials in ascending order.

NOTE: Both increase in size with dark-adaptation.  
Tracings were derived from a 16 mm time-lapse  
sequence.

intensity is approximately 200 X greater than bare lamp). Periodic stimulation of the eye with light flashes subsequent to its placement in the perfusion and recording apparatus allowed the recording of the ERG and optic nerve response during the dark adaptation process (Figure 7). The frog eye is much smaller than the cat eye, necessitating the construction of a different eye holder for the frog. Because the frog eye was maintained at room temperature, there was no need to use the water jacket. A light-tight box (Figure 8) was constructed of black 10 mm thick lucite. It, too, had an aperture with a 5 mm glass bead to concentrate the light onto the frog retina. The cradle in the box was designed to accommodate either a large (Rana catesbeiana) or a small (Rana pipiens) frog eye. Figure 9 shows a diagram of the holder used for all subsequent experiments, to maintain the frog eye aligned with the stimulating light and to catch the effluent for the drop counter and maintain a stable position for the recording electrodes.

### Electrodes

#### A. Silver-silver Chloride (Ag-AgCl)

The potentials encountered when recording from the eye and optic nerve dictated the choice of electrodes to be used. It was necessary to use electrodes free of noise and drift. Stainless steel electrodes can produce noise of 5 to 50  $\mu$ V with considerable drift. Metallic silver produced numerous spike-like "pops" (Kado & Adey, 1968). The silver-

# OPTIC NERVE POTENTIAL

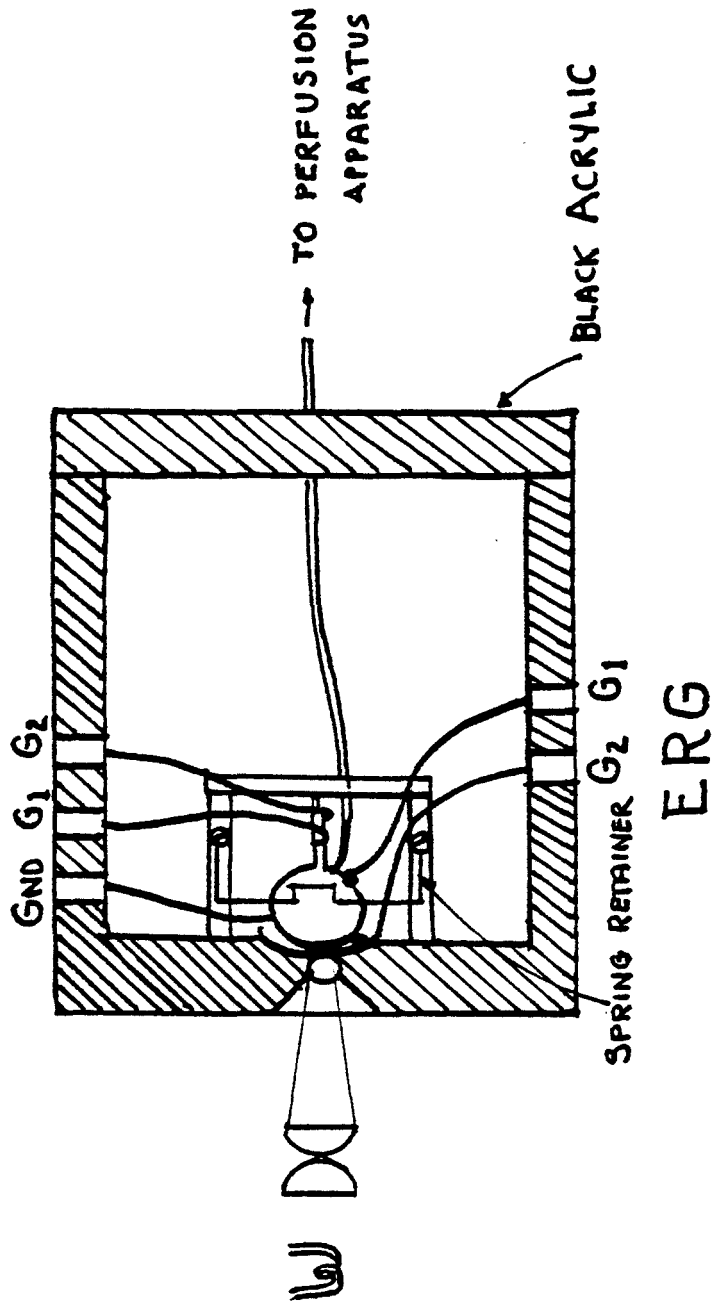
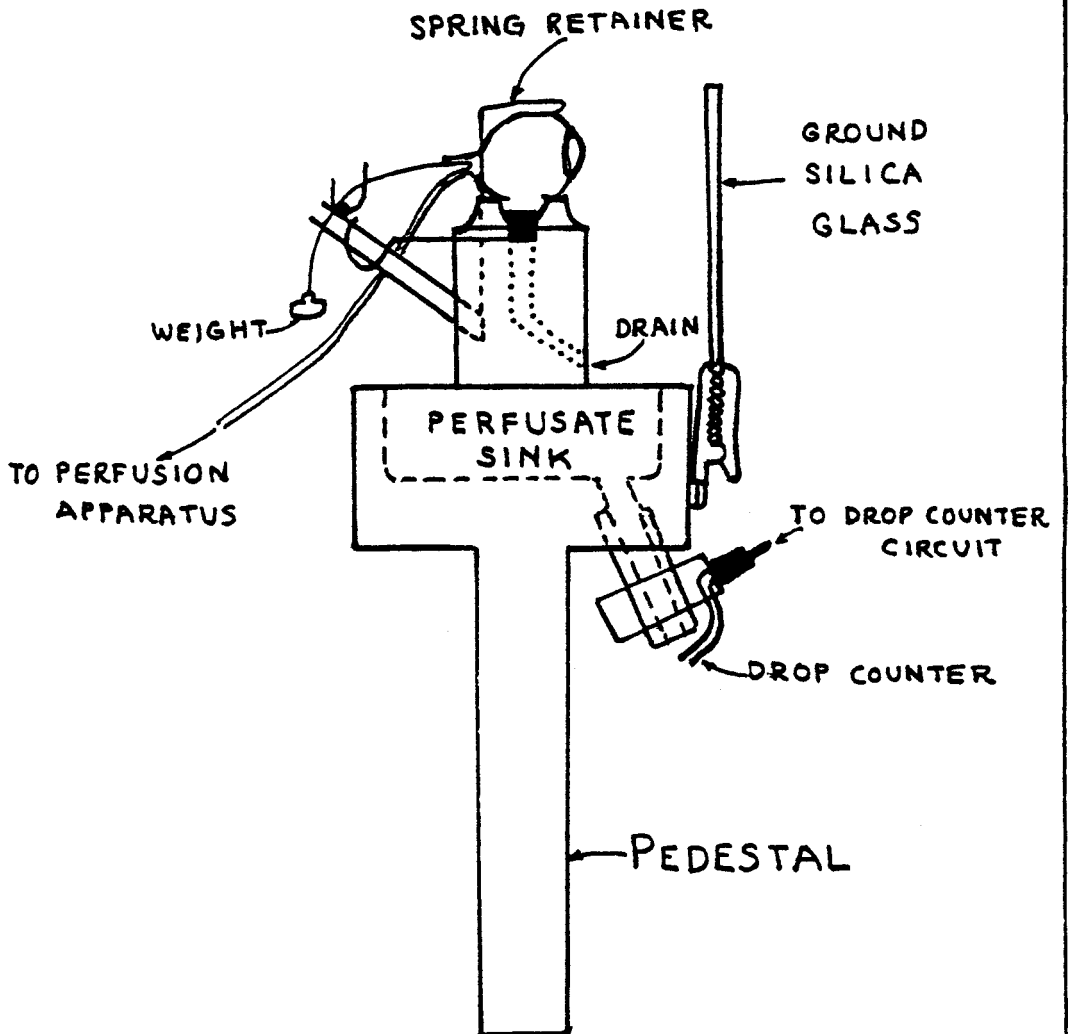

Figure 8 Schematic diagram of light-tight chamber for frog isolated perfused eye

The eye is held in place by a stainless steel spring. Light generated by a strobe lamp is focused on the retina by means of a system of condensers and a glass bead. Appropriate electrodes (cf. text) are placed to measure the optic nerve potential and the ERG. Drugs and perfusion media are delivered by means of a polyethylene cannula (PE #10) attached to the ophthalmic artery. Dimensions of the chamber are 7 X 7.5 X 10 cm. The black acrylic plastic is 9.5 mm thick.



ISOLATED EYE HOLDER

Figure 9                    Isolated eye holder

The holder was machined from acrylic plastic. The eye sits in a cup-like depression at the top and is maintained in place with gentle pressure by a fine stainless steel spring. A hole drilled through the center of the cup provides a drain path for the venous effluent, this in turn empties into a perfusate sink which drains through an acrylic tube. An adjustable drop counter monitors the effluent.

silver chloride (Ag-AgCl) electrode was chosen to record ERGs and optic nerve potentials for the early series of experiments. Ag-AgCl electrodes can be used in a variety of configurations, and they do not significantly contaminate the medium in which they are used (Janz & Ives, 1968). One problem encountered with the use of Ag-AgCl electrode is the production of transient potential artifacts when exposed to a flash of light. A similar change of electrode potential using a silver halide electrode was reported by van Peski et al., (1969). They found that a flash of light caused transient changes characterized as a fast deflection followed by a slow return to equilibrium when they recorded the potential of a silver-silver iodide pair of electrodes immersed in an electrolyte solution. This was one reason Ag-AgCl electrodes were discarded for recording the ERG. Another problem encountered was the tendency of the electrode-cornea interface to dry out, thus there was a constantly changing recording condition which produced artifacts.

Ag-AgCl electrodes were prepared from silver wire of 0.625" and 0.006" diameter. Ball tipped electrodes (for ERG) were produced by exposing the tip of the wire to the flame of an oxygen-butane torch. The wire pairs to be coated were placed in an electrolyte solution and formed the anode with a carbon rod as the cathode. A current of



1 mA/cm<sup>2</sup>/hr. was passed through the wires forming a smooth adherent buff-colored coat of AgCl (Janz & Ives, 1968). The electrode pairs were washed and stored, shorted electrically to one another in saline solution. To determine whether a galvanic potential existed after storage the electrodes were connected to the terminals of a Beckman model 72 pH meter. A measurement of zero volts indicated they they were fully discharged.

#### B. Calomel Electrodes

The Ag-AgCl electrodes initially used were unsatisfactory for long-term recordings from the surface of the eye. Even the relatively-slight dessication due to evaporation of media at the electrode-cornea and electrode-scleral interface caused problems of noise and drift. Intraocular micropipet electrodes fabricated from capillary tubing drawn to a fine tip produced stable ERG recordings (Brown & Weisel, 1961). However, they drift over a long time period. Lurie (1973) who encountered problems with long-term drift and noise reported failure with wick electrodes, Ag-AgCl surface electrodes and KCl-filled pipette electrodes. A moistened wad of cotton containing a Ag-AgCl wire placed in the mouth of his in vivo frog preparation made a more stable reference electrode but long-term baseline drift made this method unsatisfactory. His solution was to use two capillary electrodes filled with Ringer's

# CALOMEL HALF CELL ELECTRODES

(a)

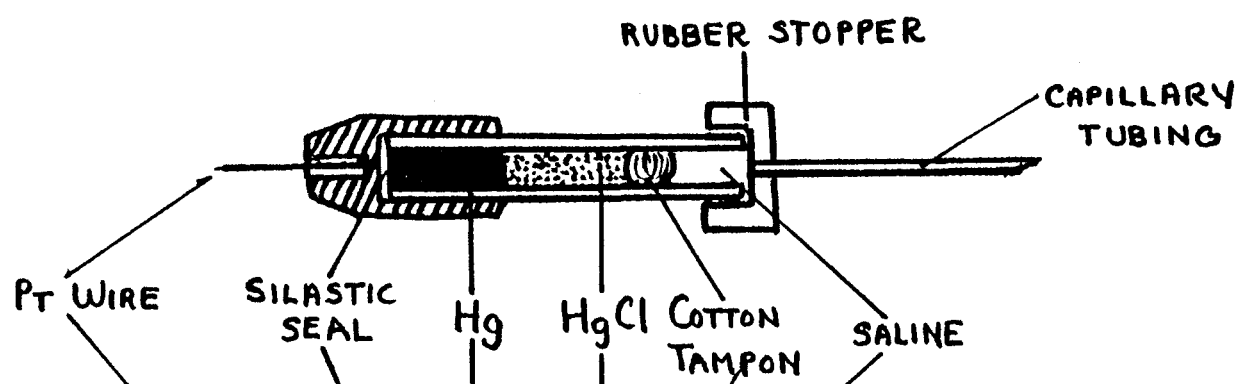

(b)

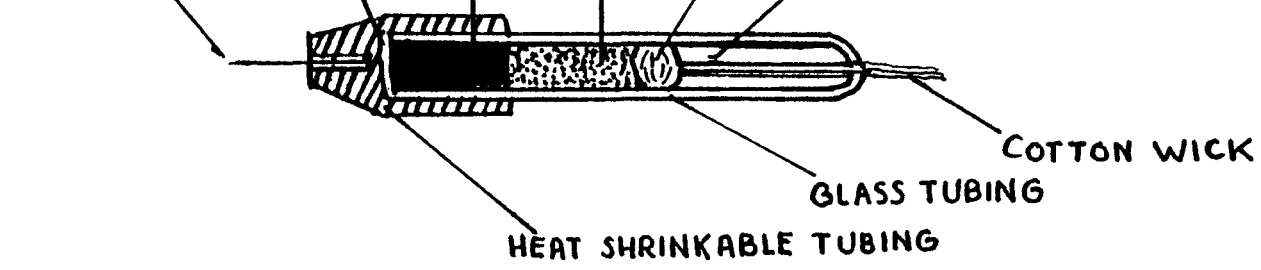
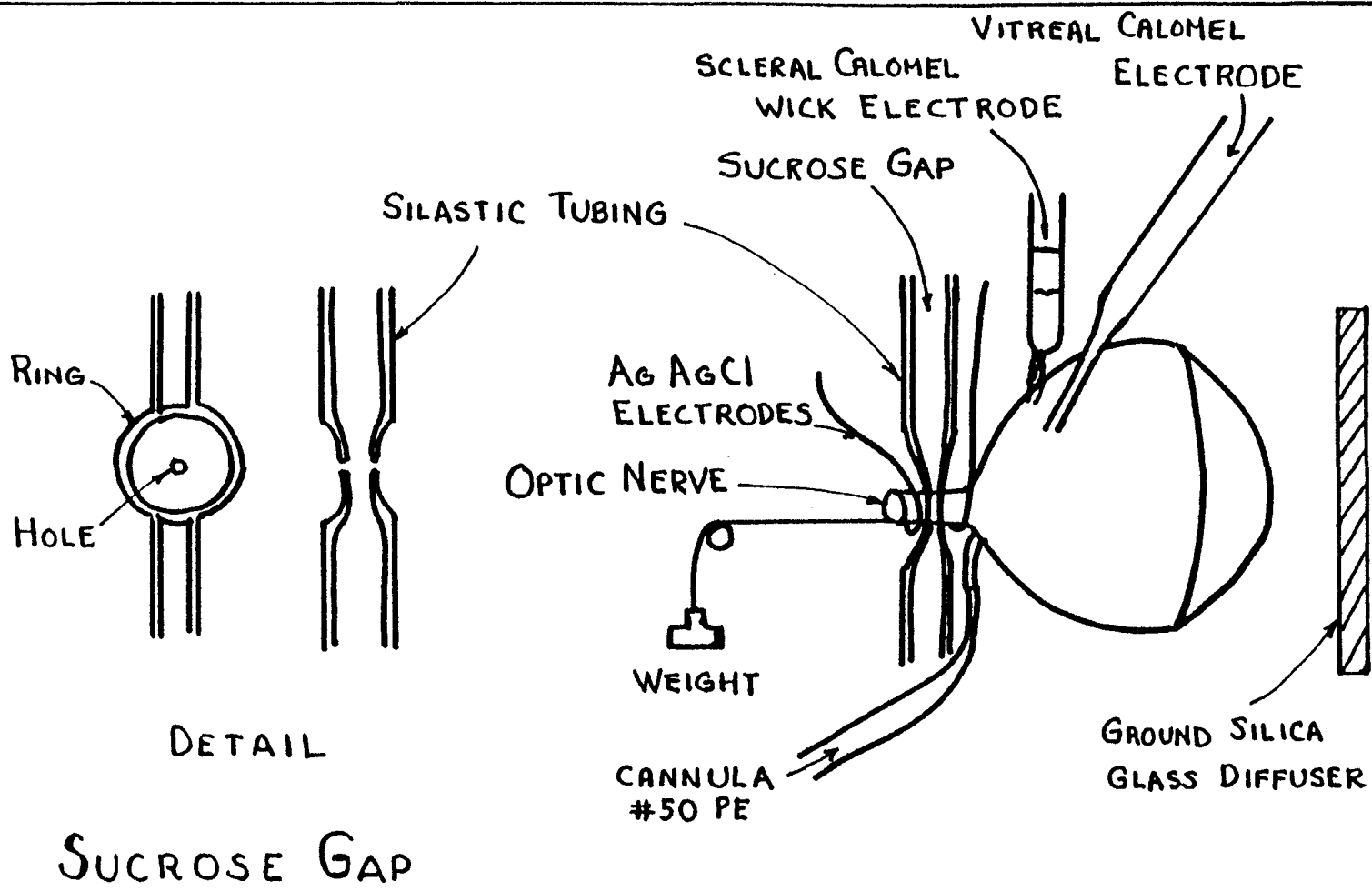

Figure 10      Construction details of  
                 miniature calomel half-cell electrodes

- (a) Intravitreal electrode. The capillary tubing tip approximately 3.5 cm long is inserted through a small hole in the sclera into the vitreous humor just behind the lens.
- (b) The scleral wick electrode is placed on the posterior pole of the globe where it is bathed continuously by the venous effluent of perfusal media.

saline and specially prepared Ag-AgCl wire to lead off the responses. Knave (1970) in long-term d.c. recordings of the ERG used two recording calomel half-cells connected to the preparation by saline bridges in polyethylene tubes filled at the tip with surgical cellulose sponge. The tips were inserted into low vacuum contact lenses. This system provided great stability and freedom from light-induced artifact. However, technical problems in producing such a lens for the isolated frog eye necessitated choosing an alternative method in using the calomel-half cell electrodes in the preparation. Miniature calomel-half cells were constructed after Burés et al., (1960). Figure 10 shows the construction details of the electrodes. Calomel ( $\text{Hg}_2\text{Cl}_2$ , reagent grade) was washed thoroughly with 0.9% NaCl. Redistilled mercury was filtered through several thicknesses of surgical sponge until all visible impurities were removed. A tampon of saline-moistened cotton was inserted into the lumen of 3 mm glass tubing, followed by approximately 10 mm of moistened, washed calomel. Sufficient mercury was placed almost to the tip of the lumen to cover the calomel. A loop of .005" platinum (Pt) wire inserted into the mercury making certain it did not contact the calomel layer. The tip containing the mercury and Pt wire was sealed with silicone rubber. Miniature gold-plated contacts were swaged onto the ends of the Pt wire and several layers

of heat-shrinkable tubing formed a stable strain-relief so that the wire could not be pulled out or broken off. Current (d.c., 1mA) was passed through the Ringer-filled electrode in alternate directions until zero current could be measured. The electrodes were stored until needed, shorted to one another in NaCl solution. They are stable, noise-free and accurately record the potentials occurring in the eye. These electrodes, however, are temperature sensitive necessitating the monitoring of temperature during an experiment. The forward ends of the calomel electrodes were filled with frog Ringers solution. Two types of electrodes were constructed. One was capped with a rubber stopper which was penetrated by a Ringer-filled smaller capillary tip forming the active electrode. The other was drawn to a smaller tip and a cotton wick inserted. This was the indifferent electrode. The wick was adjusted to contact the posterior sclera of the eye (Figure 11), so that the effluent from the superior and/or ventral bulbar vein continuously flowed over its tip. Penetration of the eye was accomplished by puncturing it with a sharp hypodermic needle (#21). The fine-tipped capillary microelectrode about 20  $\mu$  in diameter was pushed through the puncture into the vitreous using a micromanipulator.



SUCROSE GAP

Figure 11 Schematic diagram of electrode  
placement, isolated perfused eye

Detail illustrates construction of sucrose gap from  
silastic tubing. The gap measures approximately 1.5 mm  
in diameter; central chamber 3 mm in diameter.

## Recording from the Optic Nerve

### A. Special Problems with the Perfused Eye

To assess the simultaneous activity of the ganglion cells whole nerve recording was chosen. Normal recording requires that adherent tissue be removed to improve contact with the nerve. The nerve must be moist but not wet to prevent shorting out the signal. Artifacts due to muscle activity and injury potentials are eliminated by cleanly dissecting the preparation after enucleation. Numerous cut veins draining over the eye causes pooling (Figure 3) of effluent media to occur especially in the region of the optic nerve. The low electrical resistance of the saline solution tends to short out the signals from the nerve. The length of the nerve dissected was 3-5 mm seriously limiting access to recording electrodes. The following approaches to solving the problem were attempted:

1. Wrapping Ag-AgCl electrodes around the nerve insulated with mineral oil proved unfeasible because the oil was washed away by the effluent.
2. An active calomel cell electrode was placed surrounding the cut end of the nerve assuring optic nerve recordings. However, because of the limited nerve length it was not possible to place the indifferent calomel electrode in such a manner as to isolate it from signals originating distal to



the ganglion cells. Consequently, a mixed response was obtained part optic nerve and part retro-orbitally-obtained ERG.

3. Ag-AgCl electrodes were used with a thin rubber dam to insulate the electrodes from one another. Again, the venous effluent built up an ohmic bridge between the electrodes and reduced their effectiveness.
4. Finally, a sucrose-gap was designed and constructed (see Figure 11) using surgical grade silicone rubber tubing (2.5 mm OD). A stainless steel ring approximately 5 mm diameter was inserted into the lumen of the tubing to produce a double-walled flattened area. A hole was made through the double wall with a 26 gauge hypodermic needle. The tubing was connected to a bottle containing isotonic sucrose. Inserting a fine tipped jewelers' forceps through the punched holes and allowing a slight separation to occur to insert the 6.0 silk ligature from its tied cut end, the nerve could be pulled through with gentle traction. It should be noted that the reason for the sucrose gap is that capillary spaces between individual fibers on the bundle form a considerable ohmic shunt. Isotonic

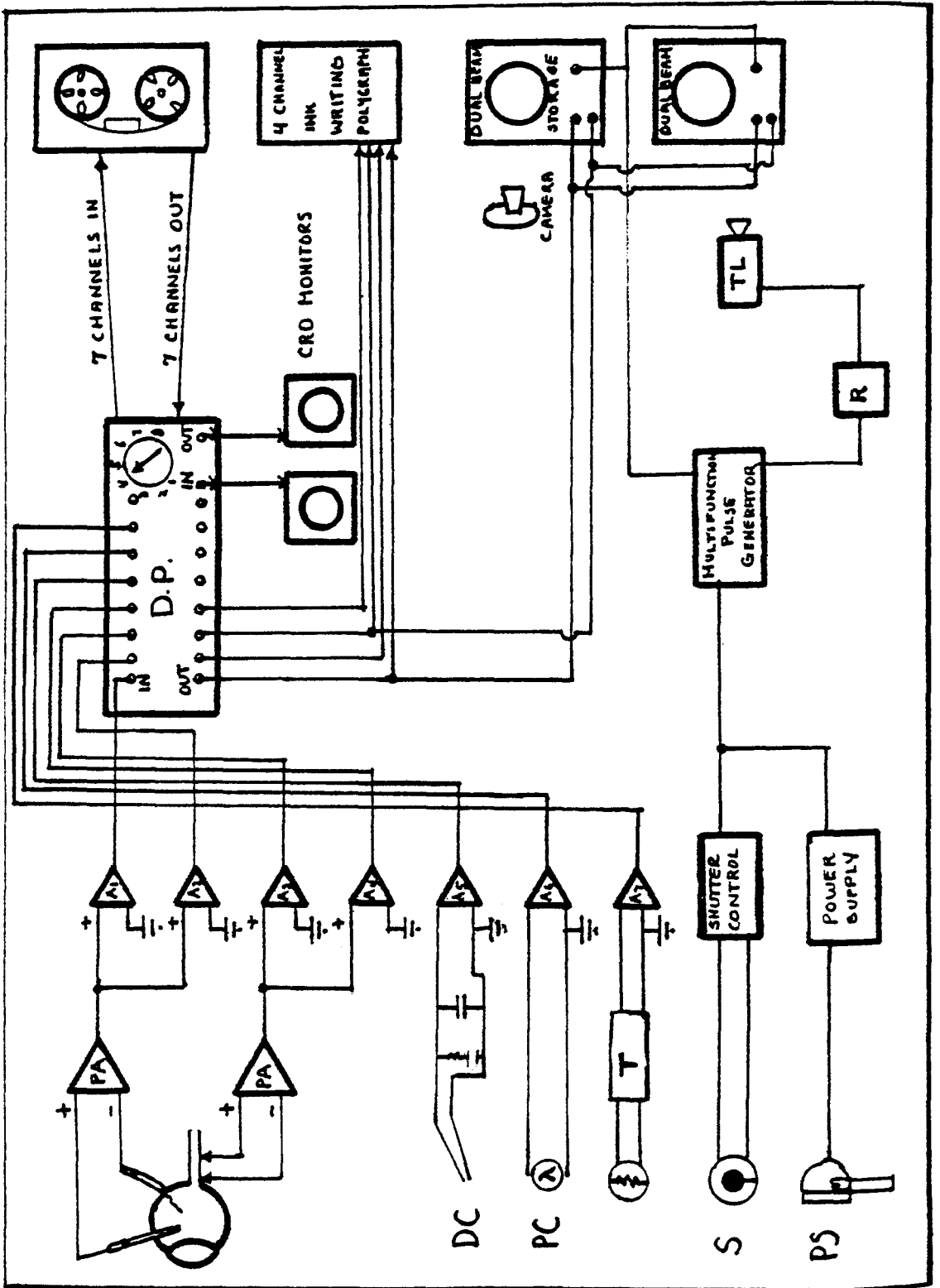

Figure 12 Schema for electrophysiological recording of isolated perfused frog eye

PA - preamplifiers for intravitreal and wick calomel electrodes, A-A<sub>7</sub> amplifiers, DC, drop counter; PC photocell; T, thermister probe; S, shutter; PS, photostimulator DP, distribution panel with monitor selector switch, tape recorder, 8-channel, polygraph, 4 channel; CRO, cathode ray monitors, camera single frame recording; R, relay; TL, 16 mm Time lapse recording camera, dual beam storage oscilloscope, dual beam oscilloscope, multifunction pulse generator, power supply.

sucrose fills these spaces, thus increasing the effective interelectrode resistance (Burés et al., 1960).

### Summary of Electronic Methods Used to Record the Isolated Perfused Eye Potentials

Potentials generated by the eye were led off by the electrode systems described to differential preamplifiers (Figure 12). The ERG and SP were differentially connected to the cathode follower input ( $>10M\Omega$ ) of a Grass P6 d.c. preamplifier, the corneal or vitreal electrodes were positive (+) and the indifferent electrode negative (-). The optic nerve electrodes were similarly connected to the input stage ( $>2 \times 10^8\Omega$ ) of a Grass P18 B d.c. preamplifier. The differential output of the P6 amplifier was connected to ground providing single ended output. Each preamplifier was connected to the input stage of a Grass DP 9B a.c. amplifier with  $\frac{1}{2}$  amplitude frequencies set at 2 hz (low) and 2000 hz (high). The output stages of the P6 and DP9B a.c. amplifiers were connected to the input stages of buffer amplifiers which raised the output voltages of the preamplifiers to a level compatible with the tape recording system used. (Cf. Figure 13 for a.c. vs d.c. recorded ERGs).

Drop counting was accomplished by placing two exposed electrodes in the path of the perfusal effluent, each drop produced a pulse which discharged a R-C network. A photo-cell placed in the path of the light beam from the photo-

A

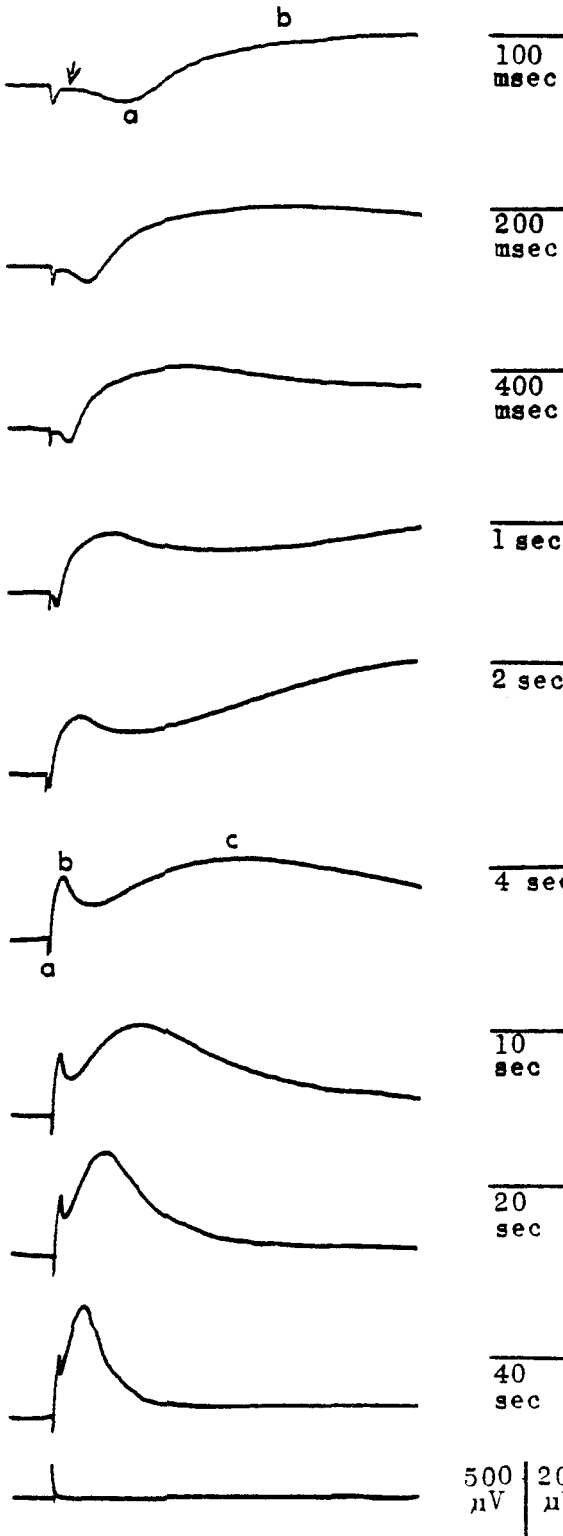

B

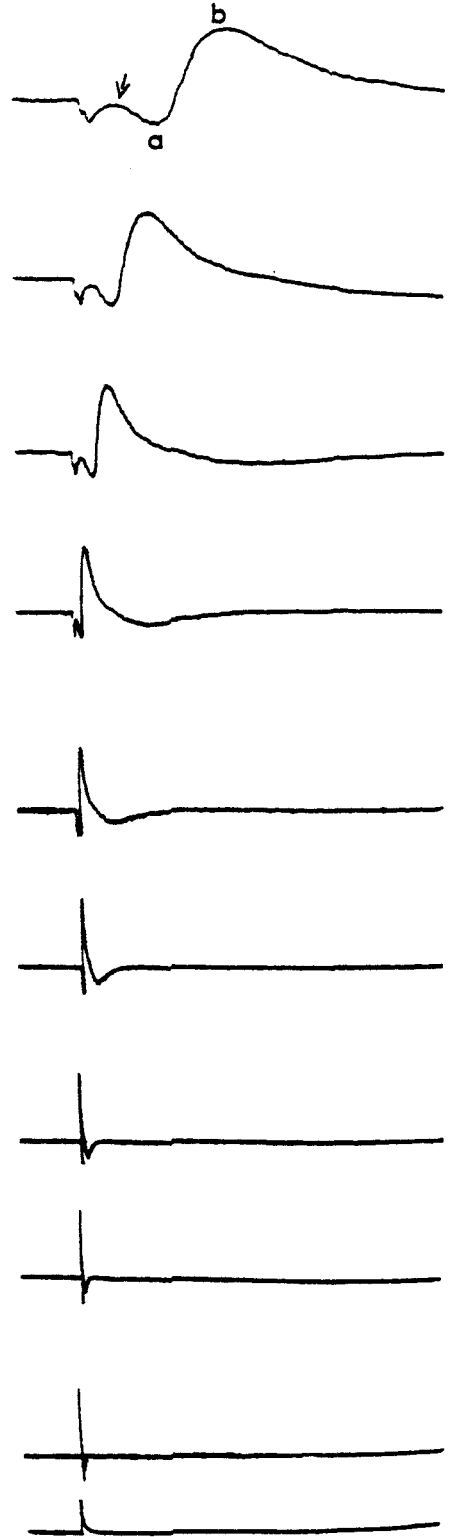

Figure 13 The electroretinogram of the  
isolated perfused frog eye

&

Comparison of ERGs recorded simultaneously  
using d.c. and a.c. recording techniques

Column A shows the development of the components of the d.c. ERG at different polygraph recording speeds. The c-wave is remarkable for its long time-course and it is notably absent when recorded by the a.c. technique (column B). Arrows at the top of the figure indicate a positive-going component with similar time and voltage characteristics of the early receptor potential (ERP). The marker at the base of each column indicates the stimulus produced by the discharge of a xenon flash tube.

Coupling the d.c. amplifier through the a.c. amplifier causes a differentiation of the ERG signal. A property of differentiating circuits is that their output is directly proportional to the slope of the input voltage. The components of the ERG as can be seen in A occur at the low end of the frequency spectrum accounting for the attenuation of the b-wave. The reason the b-wave is smaller in B, even though it is calibrated at a higher gain setting, is because a.c. amplifiers are nonlinear at low frequencies and the output voltage at these frequencies is lower.

stimulator provided an indication of the stimulus period. A YSI telethermometer thermister probe was placed close to the isolated eye preparation and monitored ambient temperature. The above instrumentation was connected to appropriate buffer amplifiers which were led off to the Distribution Panel. The distribution panel received the input from the seven buffer amplifiers and allowed the signals generated during the experiment to be recorded simultaneously on a seven channel d.c. tape recorder and 4 channel Grass ink writing polygraph. Selected input and output was monitored on oscilloscopes. The output monitor displayed the tape recorded signal. Two additional oscilloscopes were used. A Tektronics Model 502 dual-beam instrument displaced individual responses for the 16 mm time-lapse camera while individual photographs were made from the face of the Tektronics Model 564B storage oscilloscope with a Polaroid camera. A Grass Model S-88 stimulator served as a multifunction pulse generator providing signals which the oscilloscope sweeps, activated the photostimulator and time-lapse camera. It also provided the interval between stimuli.

#### The Photostimulator

Light from a 6V-18A tungsten ribbon filament operated at 5.0, 5.5 and 6.0 volts was focused on the input slit of a Bausch & Lomb grating monochromator. The output beam of

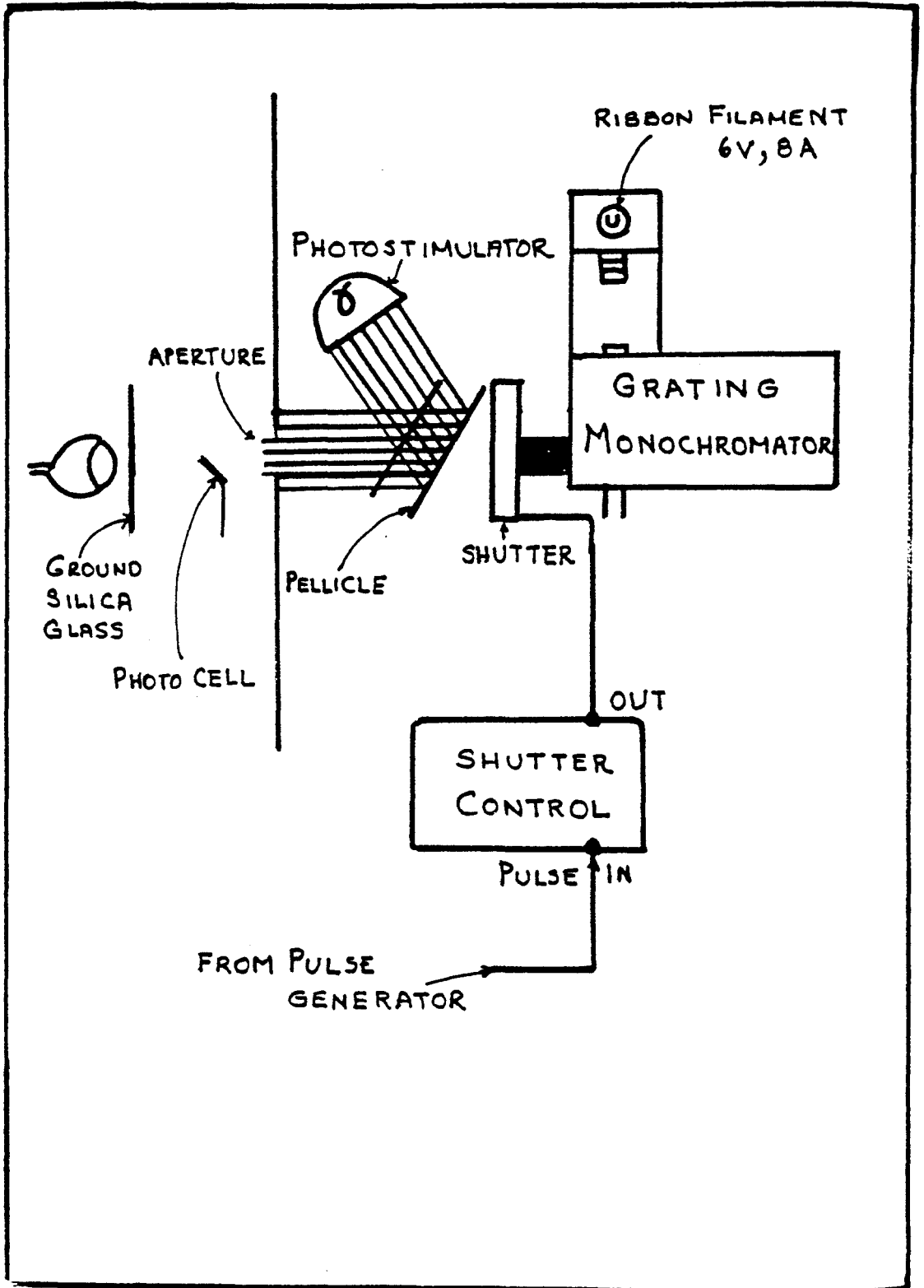



Figure 14      Arrangement of components  
                  controlling light stimuli

Light from ribbon filament lamp passing through a monochromator produces collimated beam of monochromatic light. Electromagnetic shutter occludes or passes beam to eye. Pellicle at angle in front of monochromator provides minimal attenuation of monochromatic beam and also provides coaxial beam path for xenon flash photostimulator.

the monochromator is focused for parallel rays of light and is directed at the isolated perfused eye. A ground glass diffuser is placed 25 mm from the eye (Figure 14).

Square wave shaping of the stimulus was accomplished by using a Vincent Associates Model 225 electromechanical shutter operated by a V.A. Model 310 shutter time control. A Grass PS-2 photostimulator was used to provide pulses of very short duration (10  $\mu$ sec.). Rays from the photostimulator were directed to a transparent, partially reflecting pellicle which reflected the flashes to the eye using the same light path as the monochromator.

#### Time-Lapse ERG

Time-lapse cinematography allows processes too slow to be perceived by eye at original time to be detected by time compression. What is achieved is the visualization of ongoing processes as a continuum. The human mind is able to discriminate signals from a noisy background by suppressing noise. This could also be achieved but at a considerably greater cost using on-line computers with an analog-to-digital interface for the conversion of data to specific units. Time-lapse photography produces a permanent record of a dynamic process at a relatively low cost and with less technical problems than with a computer system. A single ERG can be described by an infinite series of points which the human mind can appreciate at a glance, but

which a digital computer can only approach by approximation. Analysis of the film record can be accomplished by viewing the film projected at the usual 24 frames per second or by using special motion analysis equipment. The film can be projected at any rate from 0 frames per second to projection rates greater than 24 frames per second thus slowing down or speeding up the activity recorded on the film. Repeated projection of loops of time-lapse records allows one by repetition to visualize phenomena which are missed when seen only once or twice.

It was necessary to modify a 16 mm motion picture camera to take the time-lapse pictures of the ERG. A synchronous motor was mounted coaxially with the single frame shaft of a Kodak Cine-Special camera so that one rotation of the motor caused one frame of the cine film to be exposed. The motor operated at three revolutions per minute, thus establishing a 20 second period as the maximum time of exposure per frame. Allowance had to be made for start-up time and run-on time after exposure. This was accomplished by mounting a cam machined from plexiglass (Rohm & Hass<sup>R</sup>) on the shaft of the motor. A micro-switch with a roller actuator engaged the detent in the cam to stop the motor and a timed pulse delivered to a relay from S-88 stimulator closed the circuit allowing the motor to start up when the micro-switch actuator was seated in the cam detent (its

normally off position). The variable shutter mechanism of the cine special camera was adjusted to remain open only during the sweep time of the oscilloscope. 16 mm Kodak Tri-X or Plus-X cine film exposed in the camera was processed as a negative and projected. Processing as negative instead of reversal allows the preparation of individual prints an example of which can be seen in Figure 7. It should be noted that when the C-4 Kymograph camera (Grass) was used the absence of a positive intermittent advancing mechanism in this camera caused the image to wander in a vertical manner much like a television set with maladjusted vertical sync. control and limited its use for cinematographic purposes.

### Experimental Design

The cannulated eye was mounted on its supporting pedestal and oriented toward the stimulating light (Figure 9). The electrodes were placed on the optic nerve, intravitreally and on the surface of the globe. A thermally insulating box covered with foil and light-tight except for the light path entry, enclosed the eye. The ground glass was adjusted to assure that the entire retina would be stimulated by diffuse light. The preparation was allowed to adapt for about a half-hour while various adjustments were made with respect to flow rates, perfusion pressures, drop counting, electronic and photographic equipment. The preparation was

stimulated every 100 seconds for 10 seconds. Stimulus intensity which was at a level that did not normally evoke an a-wave was chosen such that the c-wave amplitude returned to baseline (SP) within the 100 second period. The eye is in a state of near total dark-adaptation.

It should be stated that the amount of visual pigment bleached by each stimulation was such that it was probably regenerated during the intrastimulus interval as evidenced by the stability of the standing potential baseline. The association of a constant effect, e.g., b-wave amplitude, with constant stimulus intensity is a common property of photochemical systems known as the Bunsen-Roscoe Law. Drugs dissolved in Sickel's media were delivered by either of two methods: (1) as a single retrograde injection into the perfusing system while momentarily interrupting flow by the use of a 3-way stop cock. (2) In a reservoir containing a specific volume of the diluted drug. The usual inter-drug interval for single injections was 10 minutes. The time for the perfusion of a volume of diluted drug, e.g., 20 ml, was determined by the flow rate of the particular eye. The preparation was viable for periods of up to 9 hours.

#### Data Handling, Treatment and Analysis

As many as seven experimental parameters were measured simultaneously using the Grass P7 polygraph and/or the Hewlett-Packard 8 channel FM tape recorder. Polygraph

records were analyzed directly. Tape recorded records were rerecorded on the polygraph to generate working records for analyses. By varying tape speed and amplification, one can generate working records of potentials that range over three log units and at the same time pick up details ordinarily lost at slow or fixed recording speeds (cf. Figure 13). Standing potentials, ERG components, temperature, perfusion pressure and flow rates graphed on polygraph records were measured by eye and the data was transferred to IBM compiler sheets for keypunching on cards or direct transfer to floppy discs. These data were then fed into a plotter to produce graphs that comprise some of the figures of the dissertation. Data derived from these studies are primarily treated in a qualitative manner. Occasionally quantitative analyses were performed and subject to standard statistical procedure.

#### Chemical Agents and Drugs

Drugs and chemical agents used in the experiments are listed in Table II.

TABLE II                    CHEMICAL AGENTS AND DRUGS

<u>Chemical Agents</u>	<u>M.E.</u>
Acetylcholine chloride	181.7
Aspartic acid	133.1
Atropine SO <sub>4</sub>	698.82
Bicuculline	367.34
Carbaminoylcholine chloride (Carbachol)	182.7
1-DOPA	197.2
Dopamine HCl	189.0
Edrophonium chloride	201.65
Epinephrine (base)	183.2
"          as HCl	219.7
"          as bitartrate	323.0
Gamma amino butyric acid (GABA)	103.1
Glycine	75.1
Haloperidol	375.88
Hexamethonium chloride	273.29
Histamine, as di-HCl salt	184.1
"          as di-Phosphate salt	305.65
Insulin	6000
Lactic acid	90.08
Methacholine chloride (Mecholyl)	195.7
Neostigmine bromide	303.2
"          "          as methyl SO <sub>4</sub>	334.39
Norepinephrine HCl	205.63
"          as bitartrate	337.3
Nicotine salicylate	300.23

TABLE II                      CHEMICAL AGENTS AND DRUGS  
 (Cont'd.)

<u>Chemical Agents</u>	<u>M.W.</u>
Ouabain (base)	584.64
"        as octahydrate salt	728.64
Oxotremorine (base)	206.28
"        as picrolonate salt	250.28
Phenoxybenzamine	303.84
"        as HCl salt	340.29
Physostigmine (serine)	275.34
Picrotoxin	602.57
Propranolol	259.34
Reserpine	608.70
Serotonin (5-OH tryptamine) (base)	176.21
"        as HCl salt	212.7
"        as creatine SO <sub>4</sub>	436.0
Sodium azide (NaN <sub>3</sub> )	65.02
Strychnine SO <sub>4</sub>	856.96
Taurine	125.14
Tetraethylammonium chloride, TEA Cl	165.71
Tetrodotoxin, TTX	319.28
Tremorine (base)	190.3
"        as methiodide salt	347.3
d-Tubocurarine-chloride	695.67
Tyramine	137.18



## RESULTS

The ERG of the isolated perfused frog eye has not previously been studied. In order to demonstrate that its light evoked responses (ERGs) do not differ basically from other frog preparations, ERGs were obtained under a variety of conditions. Figure 15A shows superimposed dark-adapted a & b-wave responses to increasing stimulus intensities. B represents the intensity-amplitude curves derived from the a & b-waves depicted in A. The measurement criterion used was that described by Krill (1972). The a-wave amplitude is measured from the baseline to the lowest point of the wave. The b-wave amplitude is measured from the trough of the a-wave to the highest point of the b-wave. The implicit time (peak time) for each component is the interval from the beginning of the stimulus to the highest point of the wave. Implicit time for a & b-waves increases as stimulus intensity decreases. These data are plotted in B, Figure 15 (closed circles & triangles). The results are consistent with those reported by Krill (1972) in the human. The curve of the b-wave responses (open circles) is consistent with the results reported by Hartline (1925) in the in situ bullfrog eye. Present results coincide with the lower portion of Hartline's curve. The reason the entire curve does

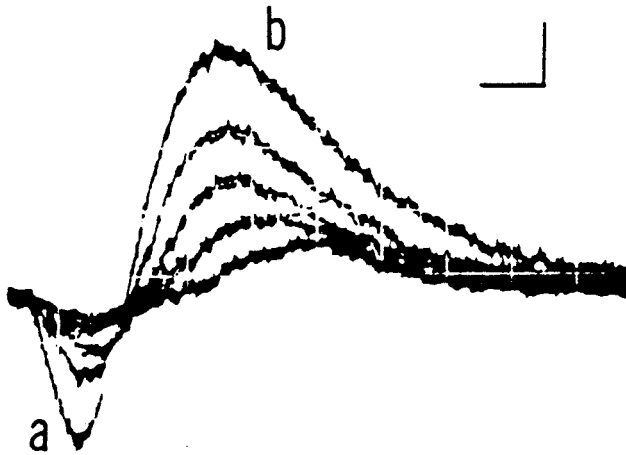

**A**

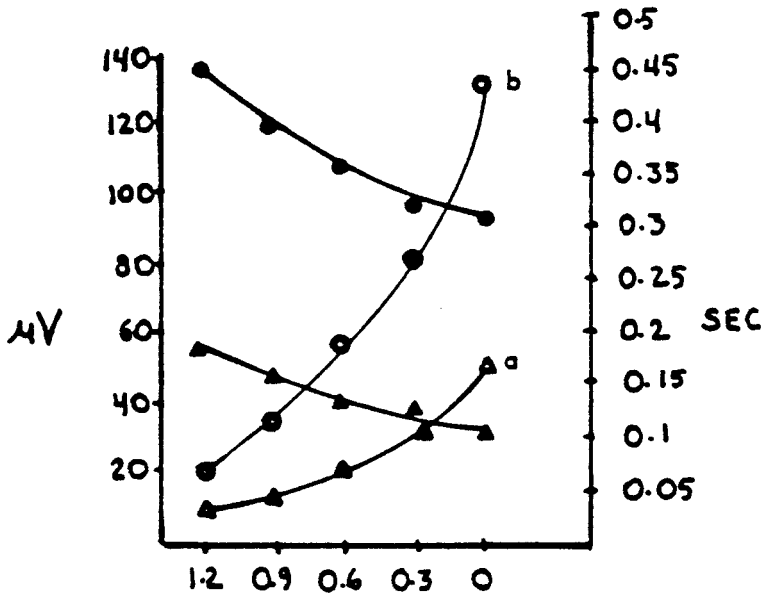

NEUTRAL DENSITY

**B**

Figure 15 (A) Superimposed a-and b-wave responses to increasing stimulus intensity

The uppermost response (maximum a-and b-wave) was elicited by the unattenuated output of the photostimulator; the balance of the responses were attenuated by neutral density filters (0.3, 0.6, 0.9 & 1.2 N.D.). Onset of 1.5 sec. duration stimulus triggered oscilloscope sweep.

Calibration: Amplitude = 20 uV

Time = 0.1 seconds

Preamplifier  $\frac{1}{2}$  amplitude frequencies: low = 1 hz  
high = 2000 hz

(B) Intensity-amplitude and implicit times of the a-and b-waves  
(derived from the ERGs in part A of this figure)

The open triangles and circles are the intensity-amplitude curves of the a-and b-waves while the closed triangles and circles show the effect of intensity on implicit time.

not match is that he used a stimulus lamp of greater intensity which spanned a greater range of values. The plot of a & b-wave vs stimulus is similar to the curves of Knave et al., (1972) obtained using the d.c. recorded sheep ERG. A lower stimulus intensity was used in my experiments in order that the d.c. recorded ERG would return to the dark baseline between each stimulus interval. Figure 16 shows the development of the c-wave as a function of stimulus duration. It can be seen in this continuous polygraph recording that when the c-wave amplitude grows progressively larger that the return to the dark baseline is impeded, thus raising the general level of the standing potential. The slight return to a lower resting level seen toward the end of the recording is due to "cycling" of the recording system which is temperature sensitive. When the ambient temperature varies, the baseline rises and falls accordingly. At 64 and 100 seconds, the c-wave amplitude grows but then reaches a plateau, when the stimulus ceases. A transient rise in voltage occurs (the d-wave) which is followed by a long, slow return to the dark-adapted baseline. Note that the b-wave at each stimulation grows successively smaller. This probably indicates that the preparation is becoming somewhat "light-adapted" since it is known that the b-wave amplitude diminishes during light-adaptation (Boynton & Triedman, 1953). The d-wave also increases



Figure 16 Continuous recording of c-wave amplitude as a function of stimulus duration

The electroretinogram from the perfused frog eye was elicited by a stimulus of constant intensity and wave length (540 nm) and of increasing duration (1,2,4,8,32, 64 & 100 seconds). At 64 and 100 seconds the c-wave amplitude reaches a plateau.

NOTE 1: The relatively small b-wave (arrow). Note also that b-wave (2nd arrow) diminishes with rising standing potential. A d-wave is clearly evident after stimulus durations > 32 seconds.

NOTE 2: The shift in baseline is attributable to temperature induced drift of the recording system.

Calibration: Amplitude = 700  $\mu$ V, Time = 25 seconds

progressively in amplitude beginning with a 32 second stimulus and continuing at 64 and 100 seconds. Brindley (1970) notes that the "off-effect" or "d-wave" is generally more prominent in the light-adapted than the dark-adapted eye of cold-blooded vertebrates, birds and a few mammals. A possible explanation for the fall in the plateau potential in the 100 second ERG is that the eye did not have sufficient time to recover to a true dark baseline because of the frequency and duration of the previous stimulations. The effects shown here are consistent with those reported by Lurie (1973) in the intact frog eye.

Figure 16 illustrates the effect consecutively of increasing duration of light stimuli on the ERG. To determine the effect of increasing stimulus duration on the rising phase of c-wave development successive ERGs of increasing stimulus length were superimposed on the screen of the storage oscilloscope (cf. Figure 17). The traces are obtained in ascending order of duration. The slope of the rising phase of the c-wave at constant light intensity remains the same for all stimulus durations. However, the peak amplitude of the c-wave grows as stimulus duration augments. Although not shown here, longer low intensity exposures are able to produce a c-wave when shorter ones do not (Lurie, 1973) c-wave development after shorter stimulus continues beyond the termination of the stimulus. The responses shown

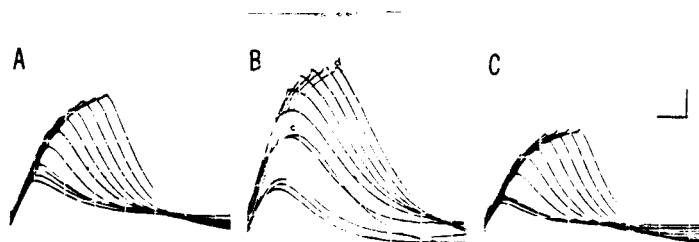

Figure 17 Superimposed c-wave responses  
to stimuli of increasing duration

Duration: 0.7, 0.9, 1, 3, 5, 7, 9, 11, 13 and 15 seconds. Traces are in ascending order of duration, i.e., the lowest trace represents the shortest time to reach the acuminate peak or d-wave (off response).

Panel A: 405 nm	Calibration: Amplitude +500 $\mu$ V
Panel B: 540 nm	Time: 5 seconds
Panel C: 640 nm	

NB: Shifting of standing potential is responsible for the gaps seen between stimulus 3 and stimulus 6, center panel (instrumentation artifact).

in panels A, B & C indicate that c-wave development at 405, 640 and 540 nm is similar.

It has been reported that the action spectrum of the c-wave is like that of rhodopsin (Granit & Munsterhjelm, 1937). Liebman, et al., (1969) demonstrated that the absorption spectrum of frog myeloid bodies (rod outer segment discs = phagocytized by the RPE) was indistinguishable from rhodopsin. Different wavelengths of radiation at equal energies and relatively high intensity were used to stimulate an isolated perfused frog eye and an eye of a curarized frog (Figure 18). This figure compares results in the in situ eye to an excised perfused eye. The amplitudes reached using relatively-broad band filters were not selective enough to determine with sufficient accuracy whether there was compliance with the rhodopsin curve. The large response of both eyes to 60 seconds of near ultraviolet (365 nanometers) was unexpected. It is to be noted that all the visible and near UV stimuli were presented for 60 seconds through an infrared-absorbing system. No measurable amount of infrared-radiation penetrated this system. Examining Figure 18, it will be noted that although a relatively large stimulus was presented to the eye in each case, only with visible light stimulation did the c-wave reach a plateau. In subsequent experiments stimulus intensity was about 1.5 log units less than that used in this



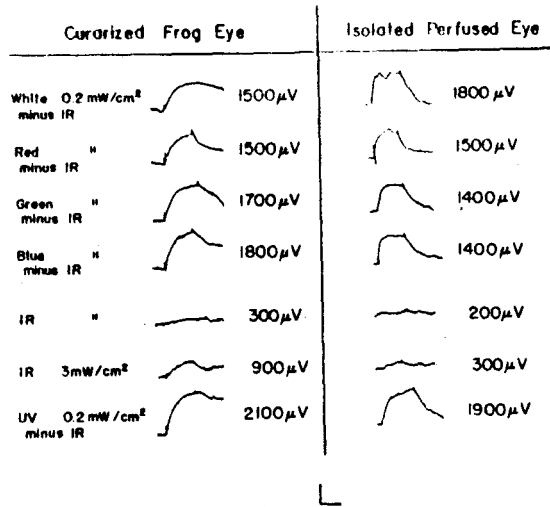

Figure 18 Action spectrum of the SP of a curarized vs an isolated perfused frog eye

This is a comparison of the spectral sensitivity of the standing potential of the intact curarized frog eye with that of the isolated perfused frog eye using wavelengths of red, green, blue and near-UV light as well as unfiltered white light and near-infrared. The intensity of the white light stimulus was chosen to approximate the level used by Kikawada (1968), i.e., 500 lux. The flux density equivalent of this level is indicated in the figure. Thus,  $0.2 \pm 0.02$  milliwatts/cm<sup>2</sup> served as a paradigm for other wavelengths of radiant energy and was measured at the corneal surface with a Hewlett-Packard Flux Density Radiometer. Comparison of results is possible because equal energy stimuli were used. Amplitudes of the intact frog eye versus the isolated eye are comparable at all wavelengths. However, the absence of IR exerts a more profound effect on the intact system.

Calibration: Amplitude = 100 μV

Time = \_\_\_\_\_ seconds

NOTE: Plateau formation is absent in the curarized eye. Compare this Figure with Figure 16.

A

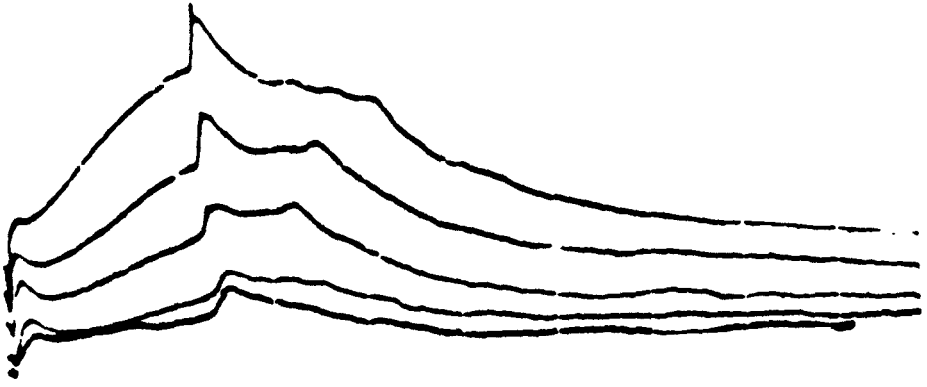

B

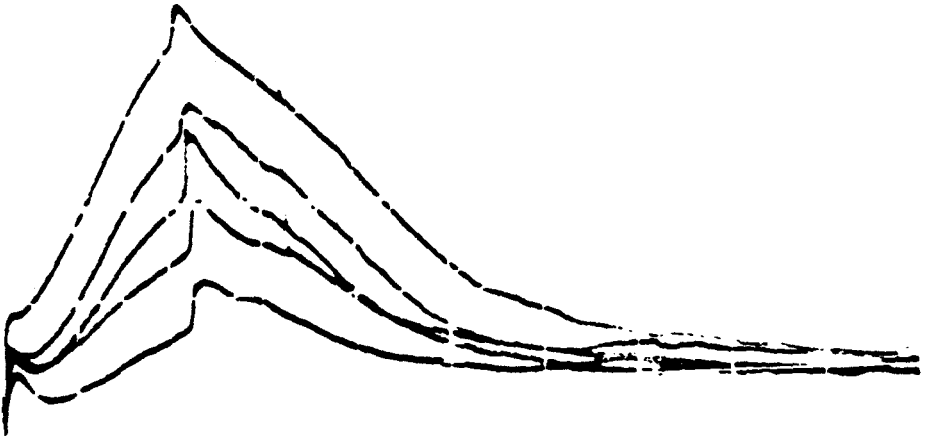

C

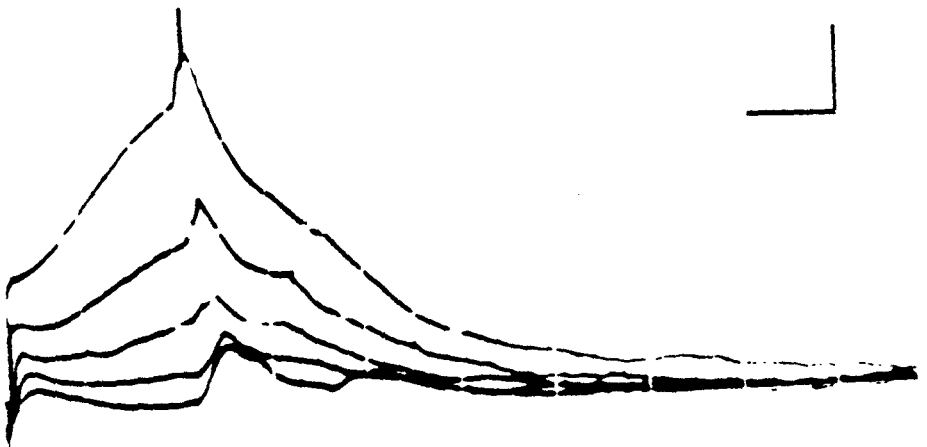

Figure 19 Isolated perfused frog eye  
c-wave in response to different  
stimulus wavelengths and stimulus intensities

Duration: constant @15 seconds. Panel A: 405 nm, B:  
540 nm and panel C: 640 nm. The uppermost  
response in each panel was elicited by the  
unattenuated output of the photostimulator;  
the balance of the responses were attenuated  
by neutral density filters (0.3, 0.6, 0.9 &  
1.2 N.D.).

Calibration: Amplitude = 200  $\mu$ v

Time: 5 seconds

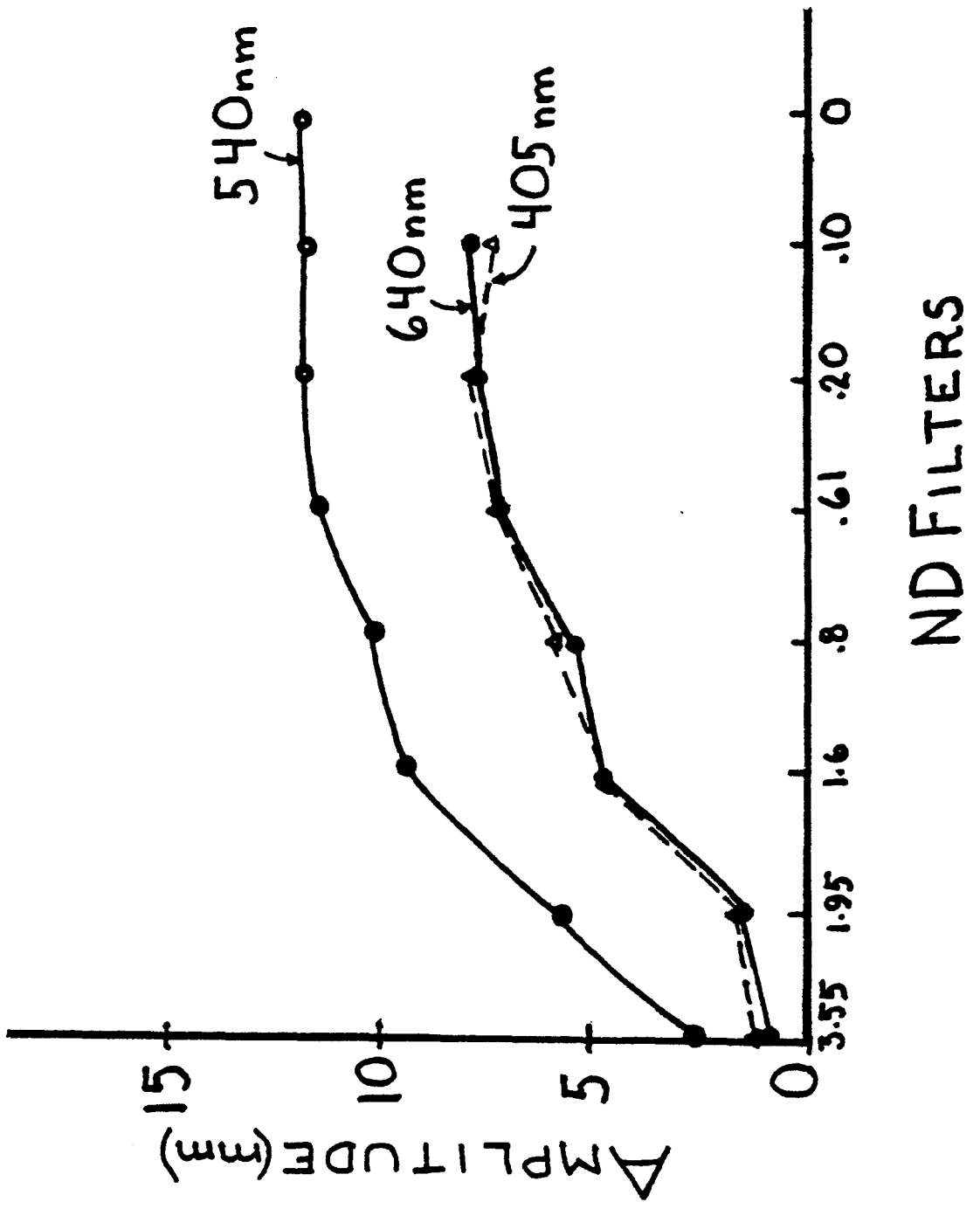

Figure 20 Growth of c-wave amplitude at  
different intensities at 405, 540 and 640 nm

Ordinate: Amplitude in millimeters. Each millimeter  
represents 80 microvolts.  
Abscissa: Intensity reduced from (0) by neutral density  
filters (ND).  
Pulse duration = 10 seconds

experiment. Whenever stimuli were delivered for more than 30 seconds, a plateau was reached. Subsequently, similar experiments were performed using narrow slit monochromatic wavelengths. These are illustrated in the following figures. Figure 19 shows the response at five intensity levels to blue, green and red stimulation. While it was preferred to use 365 nm near UV stimuli, 405 nm stimuli were chosen because the photostimulator was not capable of sufficient output at the lower wavelength and was insufficient to stimulate the eye. The plotted results of a similar experiment are shown in Figures 20 & 21. Equal energy responses were obtained from these graphs and from an additional experiment not illustrated here. The data were compared with Granit & Munsterhjelm's (1937) Fig. 4, p. 166, in J. Physiol. (Lond), in which the b-wave amplitude is plotted against wavelength. This curve actually displays the response of visual purple (rhodopsin, rod pigment). The authors suggest that this curve also represents the frog c-wave response. At 405 nm the responses from my three experiments were 92.5, 55 and 74.6% respectively, compared with their response of 30%. At 640 nm, the responses were 60, 59.4 and 67.9% respectively, as compared to 20%. The reference value at 540 nm was set to 95% in each case. The responses shown here including those in Figure 18 show a much greater sensitivity to 405 nm blue light and near UV

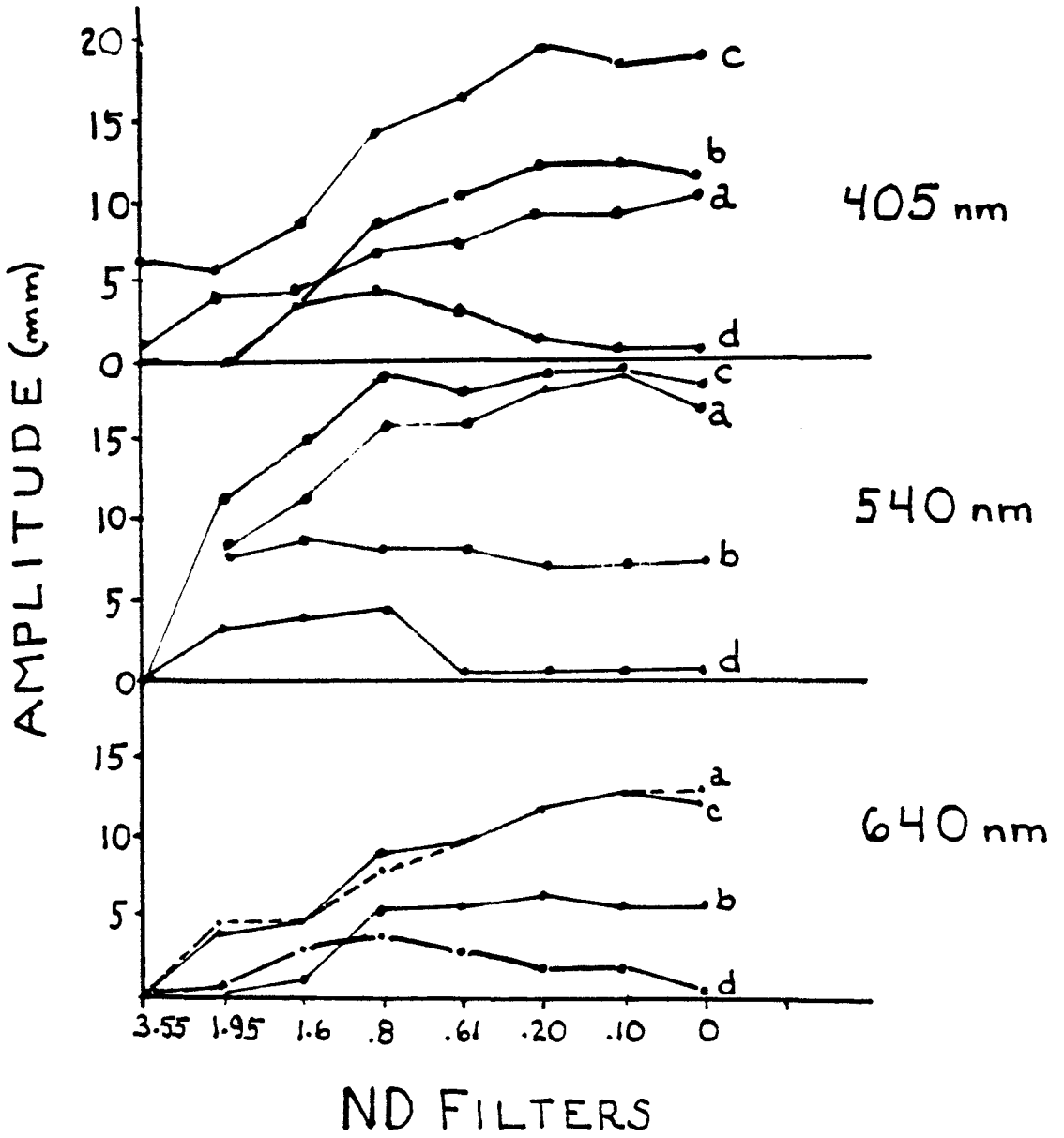

Figure 21 ERG potentials as a function  
of stimulating wavelength and intensity

Ordinate: Indicates amplitude in millimeters. For a, b, and d-waves each. Millimeter = 5  $\mu$ v for c-wave each. Millimeter = 80  $\mu$ v.

Abscissa: Light intensity modified by neutral density filters. At 0, stimulating light is unattenuated. ERG a=a-wave; b=b-wave; c=c-wave; d=d-wave or off-wave.

Upper trace: 405 nm stimuli (blue)  
Middle trace: 540 nm stimuli (green)  
Lower trace: 640 nm stimuli (red)  
Stimulus duration: 10 seconds



(365 nm) and red (640 nm) than the values found in the literature.

### Drug Effects

Several classes of drugs were administered to some of the preparations in order to assess the responsiveness of the isolated perfused frog eye to different drug types and to determine the reproducibility of these effects (Table III). This approach was used in order to derive as much information as possible from each experiment in view of the complex and difficult nature of each experimental set up. It was also realized that since a preparation was naive only to the first dose of a drug administered it would be in most instances uneconomic to restrict a study to single doses or to single drugs. Drug effects will usually be described qualitatively. Computer-generated plots of drug effects depict and summarize prodigious amounts of data. The legends describing such figures are deliberately-detailed to assist the reader. Quantitative data is also represented in the thesis either in tabular form or as dose-response plots.

Figure 22 illustrates the effects of drugs and ions on the standing potentials of the eye and optic nerve of a dark-adapted, photically-unstimulated preparation. Potassium, NE, GABA, DA and Na azide produce positive-going deflections of the SP of the eye while  $Ca^{++}$ , ACh, carbachol and

TABLE III

SUMMARY: NUMBER OF  
PREPARATIONS PER DRUG

<u>Drug</u>	<u>No.Preparations</u>	<u>No.Naive</u>	<u>% Naive</u>
Norepinephrine	6	1	16.6
Phenoxybenzamine	2	0	0
Epinephrine	3	0	0
Dopamine	14	6	42.9
Haloperidol	4	0	0
Picrotoxin	3	0	0
Glycine	5	0	0
Histamine	7	0	0
Serotonin	4	0	0
Acetylcholine	12	5	41.7
Mecholyl	4	1	25
Carbachol	8	3	37.5
TEA	3	0	0
C-6	1	0	0
Nicotine	5	0	0
Edrophonium	2	0	0
Neostigmine	1	0	0
TTX	1	0	0
Strychnine	2	0	0
Tubocurarine	1	0	0
Atropine	2	0	0
Reserpine	1	0	0

TABLE III (Cont'd)

<u>Drug</u>	<u>No. Preparations</u>	<u>No. Naive</u>	<u>% Naive</u>
Tremorine	1	0	0
Oxotremorine	1	0	0

UNSTIMULATED PERFUSED FROG EYE

PERFUSION PRESSURE

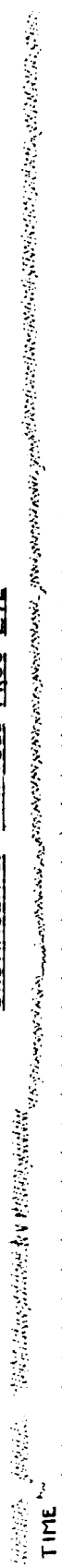

TIME

SP, EYE

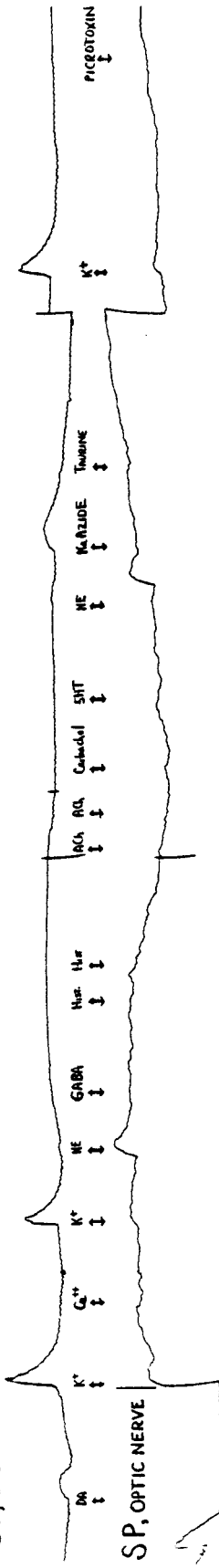

SP, OPTIC NERVE

Figure 22 Effect of drugs on the standing potentials of the eye and optic nerve of the photically-unstimulated frog eye in a pressurized perfusion system

Upper trace: relative perfusion pressure  
 2nd trace: time (16 seconds/division)  
 3rd trace: SP of the eye  
 4th trace: SP of the optic nerve

Drugs

Dopamine	$2.7 \times 10^{-3} \text{M}$	Ach	$3.3 \times 10^{-7} \text{M}$
$\text{K}^+$	$1 \times 10^{-3} \text{M}$	Carbachol	$5.5 \times 10^{-7} \text{M}$
$\text{Ca}^{++}$	$1 \times 10^{-4} \text{M}$	5-HT	$2.3 \times 10^{-7} \text{M}$
NE	$1.1 \times 10^{-3} \text{M}$	NE	$1.6 \times 10^{-3} \text{M}$
GABA	$2.5 \times 10^{-3} \text{M}$	NaAzide	$1.5 \times 10^{-5} \text{M}$
Histamine	$6.5 \times 10^{-4} \text{M}$	Taurine	$2.5 \times 10^{-3} \text{M}$
ACh	$3.3 \times 10^{-8} \text{M}$	Picrotoxin	$5 \times 10^{-8} \text{M}$

Positive deflections of the standing potential of the eye occur after dopamine,  $\text{K}^+$ , NE and NaAzide. The maximum excursion seen following  $\text{K}^+$  attains 0.65 mv. Small negative-going deflections are detectable after  $\text{Ca}^{++}$ , acetylcholine, carbachol and taurine. This is accompanied by an upward deflection of the standing potential of the optic nerve after Dopamine (not seen in this derivative record but clearly detectable in the original polygraph recording and tape of the experiment),  $\text{K}^+$ , and NE. The deflections seen after NE are: -0.88, -0.92 mv, respectively. NE: upward deflections in the optic nerve SP are negative-going.  $\text{Ca}^{++}$ , histamine, ACh, carbachol, 5-HT produce small downward deflections of the SP of the optic nerve. Oscillatory activity becomes more prominent after GABA. Azide, taurine and picrotoxin slowly increase the upward deflection. Normally light-evoked potentials in the optic nerve precede ERG potentials (Noell, 1953; Gouras & Hoff, 1970). This occurred after  $\text{K}^+$  and  $\text{Ca}^{++}$  in this experiment. However, with respect to administered drugs, there is a delay in the onset of action on the SP of the optic nerve. The delay approaches 40 seconds with the second dose of NE. Spiking activity of the optic nerve (not shown) detected by audio-monitoring of this preparation is modifiable by drug action. Dopamine,

## Figure 22 (Cont'd)

NE and histamine increase while GABA decreases spiking activity noise from optic nerve fibers behaving like ON detectors.

.....  
-----  
\*Upward deflection indicates increased perfusion pressure.

taurine produce negative-going deflections that are quite small in comparison with the positive deflections. The sign of deflection for SP (optic nerve) after DA, NE and  $K^+$  are opposite to that of SP (eye), i.e., negative-going. The deflections of SP (optic nerve) for  $Ca^{++}$ , histamine, ACh carbachol and 5-HT are small and positive. The SP (optic nerve) after azide, taurine and picrotoxin becomes progressively more negative. Drug effects on optic nerve spiking activity are detailed in the legend of Figure 22.

#### Norepinephrine

The standing potential of the eye consistently moves in a positive-going direction at NE doses ranging from  $1 \times 10^{-5}$  to  $10^{-3}M$  (6/6 preparations) and is not reversed by phenoxybenzamine. The c-wave amplitudes increase in most preparations in a dose-dependent fashion (see Figures 23-27, Table IV). It can be seen from Table IV that the greatest increase in amplitude occurs between  $5 \times 10^{-5}$  and  $10^{-4}M$ . Phenoxybenzamine  $10^{-3}M$  reverses this effect and effectively blocks a subsequent challenge of a high dose ( $10^{-3}M$ ) of NE, (Fig. 23, Table IV).

The b-wave amplitude is significantly and consistently increased by NE with doses as high as  $1 \times 10^{-4}M$  (Figure 23, Table IV). At higher doses, Table IV, Figure 23, the b-wave amplitude is depressed and not reversed by phenoxybenzamine.

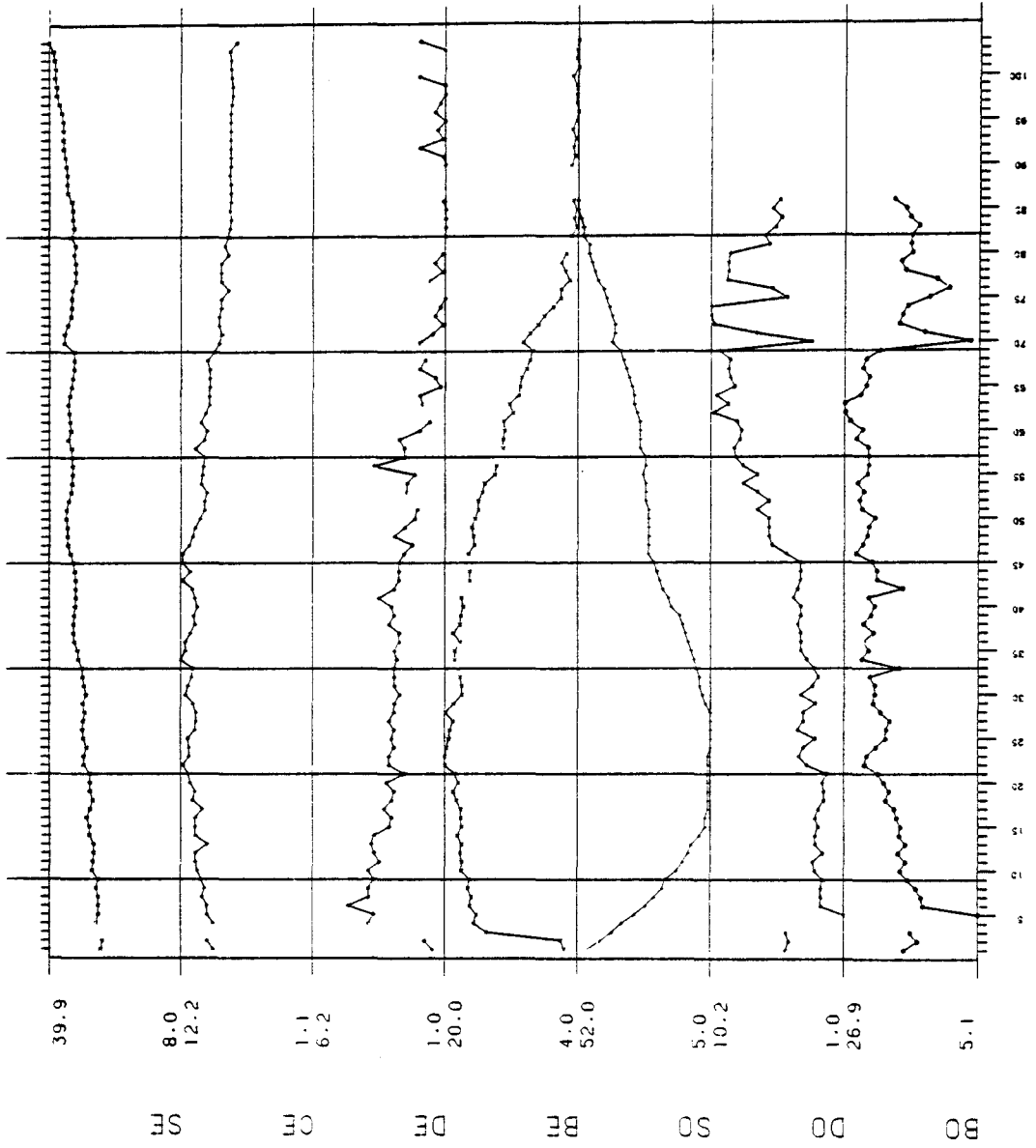

1 2 3 4 5 6 7



Figure 23 Computer plot of dose-related effects of NE on components of the ERG & optic nerve potential (ONP)

SE = standing potential of the eye  
 CE = c-wave amplitude (ERG)  
 DE = d-wave amplitude (ERG)  
 BE = b-wave amplitude (ERG)  
 SO = standing potential of the optic nerve  
 DO = "d"-wave amplitude (ONP)  
 BO = "b"-wave amplitude (ONP)

Explanatory Note: Treatments are indicated by large arabic numerals in this and subsequent computer plot figures.

Scale at base of each figure indicate 100 second stimulus interval.

Vertical lines indicate onset and/or completion of a treatment.

Ordinate scale indicates range of values in mm of excursion for each parameter as found on the original record.

NE Doses: (1)  $10^{-5}$ M; (2)  $5 \times 10^{-5}$ M; (3)  $10^{-4}$ M; (4)  $5 \times 10^{-4}$ ; (5) and (7)  $10^{-3}$ M  
Phenoxybenzamine dose (6)  $10^{-3}$  M

SE increases progressively after doses (1), (2) and (3), plateaus after doses (4) and (5); phenoxybenzamine, an antagonist of NE (6) produces a biphasic effect - A transient rise is followed by a fall below the plateau level. NE (7) further augments the standing potential. C-wave amplitudes (CE) increase with (1) and (2); plateaus after (3); falls after (4) and (5); phenoxybenzamine further depresses c-wave amplitude; (7) falls to reverse the depression

DE decreases progressively over entire NE dose range. Phenoxybenzamine (6) enhances the depression which is partly reversed by (7).

B-wave amplitude (BE) rises until after (2) then falls progressively with increasing NE doses. Phenoxybenzamine (6) produces a transient increase in amplitude; (7) substantially depresses b-wave amplitude.

SO falls progressively during control and after (1) and (2). It then rises progressively after both NE and phenoxybenzamine reaching its maxima after (7).

## Figure 23 (Cont'd)

B0 and D0 parallel each other as their amplitudes rises with increasing doses of NE and reach a maximum at (5); phenoxybenzamine (6) initiates a pronounced, slow oscillation with a period of about 10 minutes and the "b"-wave amplitude (overall) is somewhat more depressed than the "d"-wave.

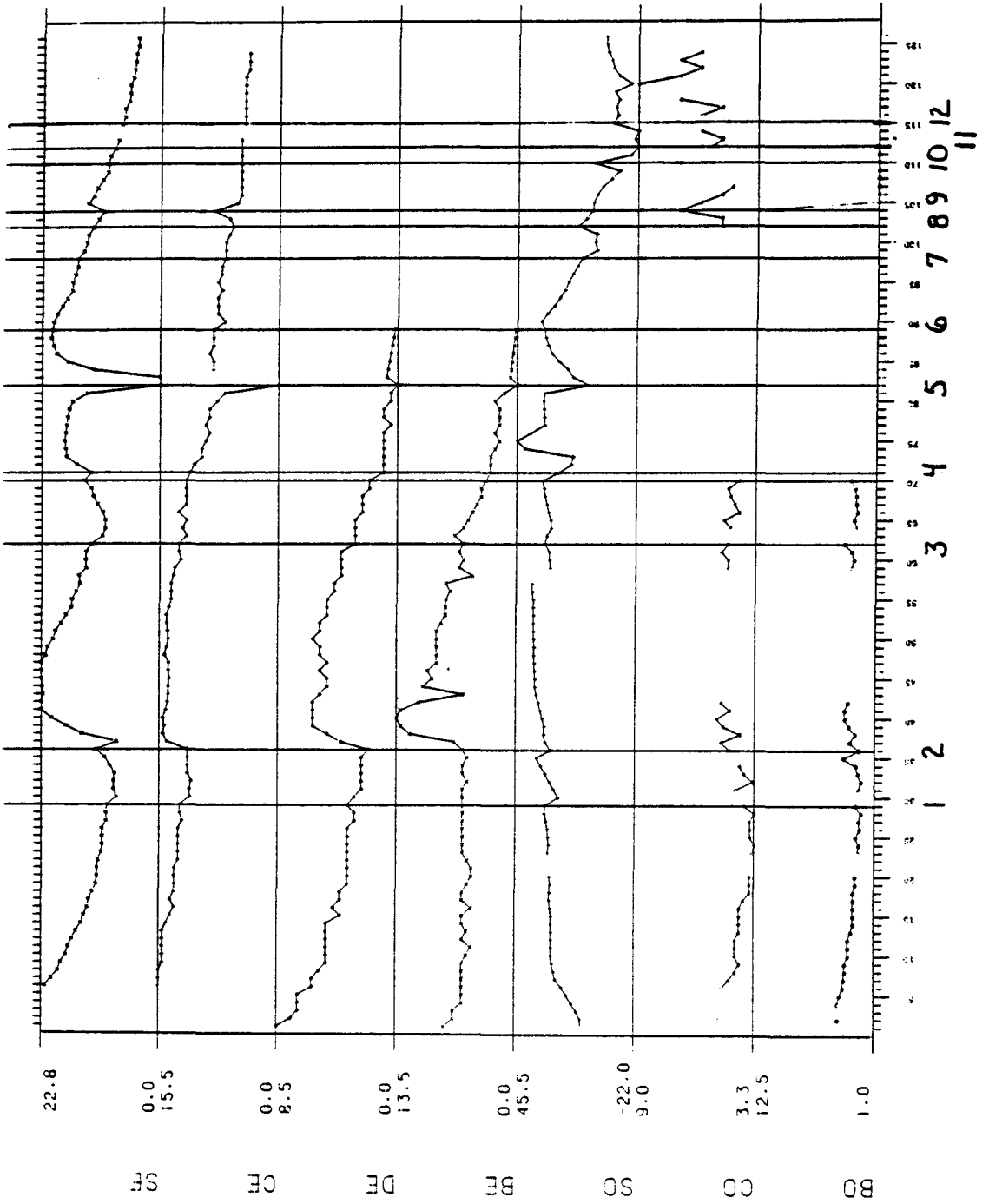

Figure 24 Computer plot of multiple drug effects on components of the ERG and the ONP  
Constant volume perfusion

SE = standing potential of the eye  
 CE = c-wave amplitude (ERG)  
 DE = d-wave amplitude (ERG)  
 BE = b-wave amplitude (ERG)  
 SO = standing potential of the optic nerve  
 CO = "c"-wave amplitude (ONP)  
 BO = "b"-wave amplitude (ONP)

(1)	ACh	$2.8 \times 10^{-5} \text{M}$	(7)	Carbachol	$1.1 \times 10^{-5} \text{M}$
(2)	NE	$4.9 \times 10^{-7} \text{M}$	(8)	Gain adjustment	
(3)	Strychnine	$1.2 \times 10^{-5} \text{M}$	(9)	Reserpine	$4.1 \times 10^{-2} \text{M}$
(4)	Mecholyl	$5.1 \times 10^{-5} \text{M}$	(10)	NE	$4.9 \times 10^{-5} \text{M}$
(5)	NE	$2.5 \times 10^{-5} \text{M}$	(11)	dTC	$2.2 \times 10^{-4} \text{M}$
(6)	Histamine	$3.3 \times 10^{-4} \text{M}$	(12)	Neostigmine	$3.0 \times 10^{-4} \text{M}$

SE depressed by (1) and becomes positive-going after (2), (5) depressed by (3) rises then falls with (4); decreases with (6), (7) and (9). At (10) there is a slight rise (compare with 2,5). The decline continues after (12).

CE follows a pattern similar to that of SE but is less prominent.

DE, BE patterns are parallel and reflect SE and CE.

SO parallels patterns above, but the polarity is always inverse to that of SE, i.e., an upward excursion indicates increasing negativity. After (10) and (11) polarity moves sharply positive and with (12) in a negative direction, i.e., upwards.

CO a rise in amplitude is the only clear effect seen.

---

Explanatory notes for components of computer plots are found in the legend of Figure 23.

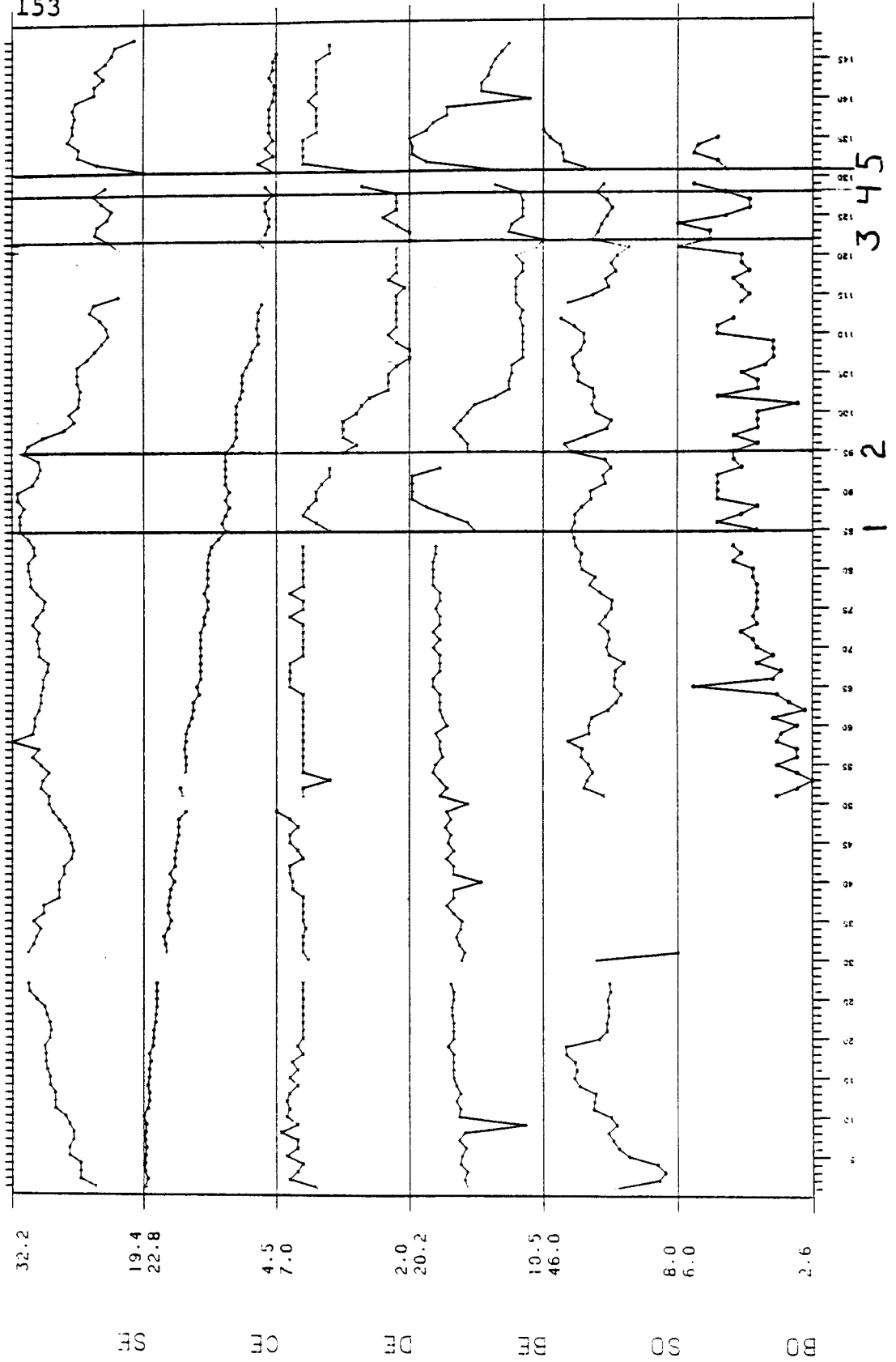

Figure 25 Computer plot of drug effects  
on components of the ERG and the optic  
nerve potential (ONP)

SE = standing potential of the eye  
CE = c-wave amplitude (ERG)  
DE = d-wave amplitude (ERG)  
BE = b-wave amplitude (ERG)  
SO = standing potential of the optic nerve  
BP = "b"-wave amplitude (ONP)

(1)	carbachol. Cl	$1.1 \times 10^{-5}M$
(2)	"	5.5 "
(3)	strychnine. SO4	$2.3 \times 10^{-4}M$
(4)	NE.HCl	$2.4 \times 10^{-5}M$
(5)	ACh.Cl	$1.3 \times 10^{-3}M$

All components of the ERG are depressed by (1) and (2) the effects on SO and BO are more variable; (3) appears to stabilize ERG components but enhances optic nerve components. The rapid succession of the administration of (4) and (5) makes it unclear which drug is responsible for the augmented effect seen in all components displayed.

---

Explanatory notes for components of computer plots are found in the legend of Figure 23.

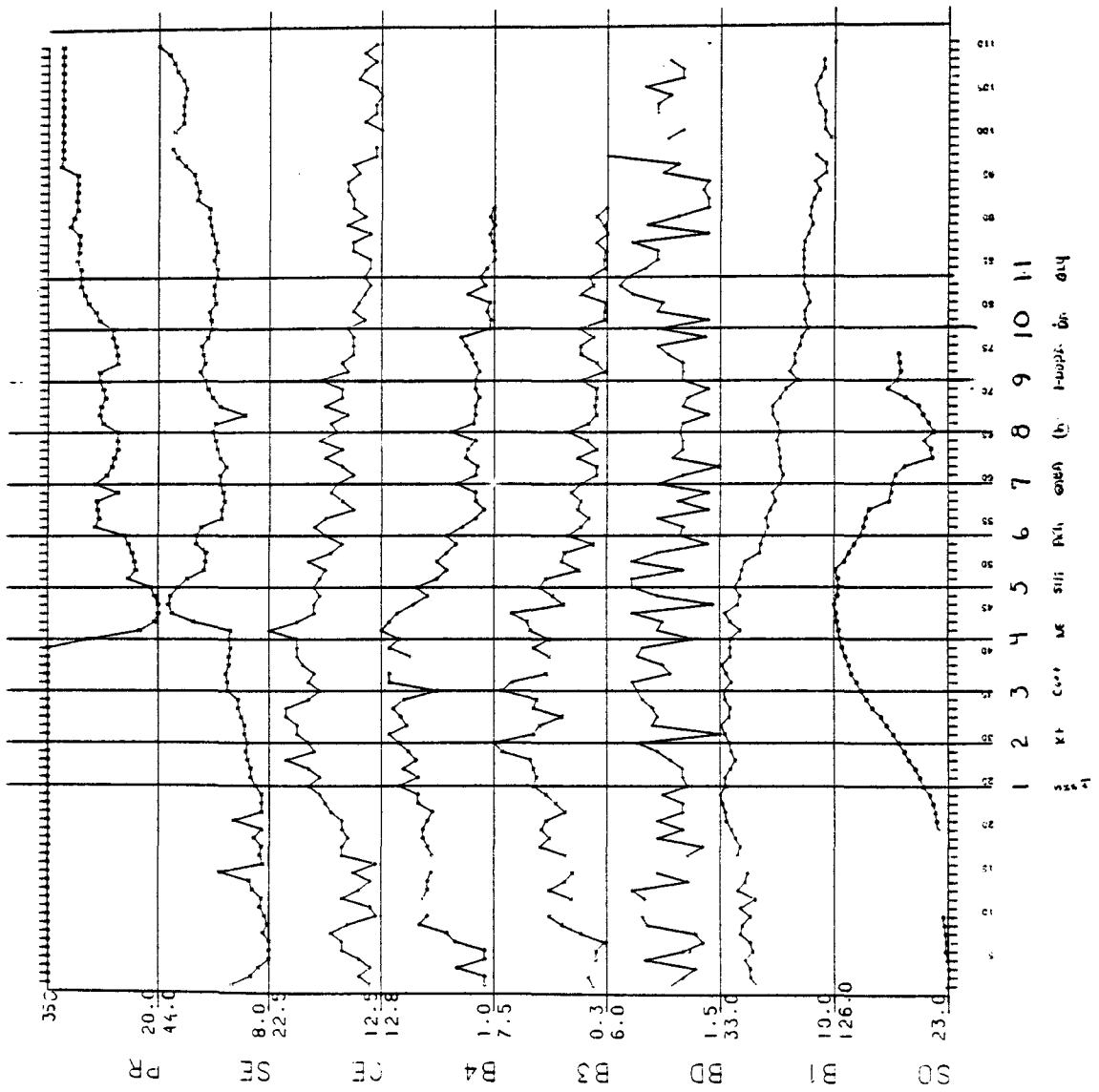

Figure 26 Computer plot of drug and ion effects on various components of the ERG, the standing potential of the optic nerve and perfusion rates

PR = perfusion rate (tachygraph readings represent min.-max. of 16.8, 34.2 drops/minute)

SE = standing potential of the eye

CE = c-wave amplitude (ERG)

B1, B3, B4 = b-wave amplitudes multiple stimuli (ERG)

BD = d-wave amplitude (ERG) confounded with a secondary b-wave (cf. Methods)

S0 = standing potential of the optic nerve

- |                              |                                   |
|------------------------------|-----------------------------------|
| (1) Sham-distilled water     | (7) GABA $1 \times 10^{-3}M$      |
| (2) $K^+$ 2.4 mM             | (8) Histamine $1 \times 10^{-3}M$ |
| (3) $Ca^{++}$ 0.12 mM        | (9) 1-DOPA $1 \times 10^{-3}M$    |
| (4) NE $1 \times 10^{-3}M$   | (10) dopamine $1 \times 10^{-3}M$ |
| (5) 5-HT $1 \times 10^{-3}M$ | (11) glycine $1 \times 10^{-3}M$  |
| (6) ACh $1 \times 10^{-3}M$  |                                   |

Flow rates in a pressurized system rather than in a constant volume system, vary as blood vessel diameter changes. Drugs affect the lability of the ocular circulation. Administration of (4) slows flow while (5), (6) and (8) increase flow. Flow rates augment with DA, (10) and its precursor DOPA (9) and SE stabilizes with (1) rises after (2) and reaches a steady state after (3). NE (4) markedly increases the positivity of the SP of the eye, (5) partly depresses it while (6) stabilizes it & (7) has little effect. (8) produces a biphasic response, initially a depression. (9) and (10) stabilize SE after its rebound from (8). At the conclusion of the experiment just after (11) it rises progressively.



Figure 26 (Cont'd)

CE: Even distilled H<sub>2</sub>O evokes a transient increase in c-wave amplitude. (2)<sup>2</sup> produces a more prolonged increase while (3) initially depresses it. (4) clearly augments while (5) tends to diminish it after (6) the effect is biphasic (7) produces an oscillation which (8) does not modify. (9) and (10) depress amplitudes while (11) partly augments them.

B1, B3, B4: evoked by successive strobe pulses during a square wave light pulse tend to parallel each other with B3 most sensitive to drug action. Drift in the rate of strobe impulses complicate evaluation.

NOTE: the parallelism between these and the c-wave amplitude.

BD: which reflects a d-wave and a drifting b-wave is variable however there is a clear increase after (9) and (10). (11) produces a transient depression.

SO: rises more rapidly (i.e., increased negativity) after (2) reaches a maximum after (4). (5), (6) and (7) decrease it (i.e., increased positivity), while (8) clearly reverses it.

---

Explanatory notes for components of computer plots are found in the legend of Figure 23.

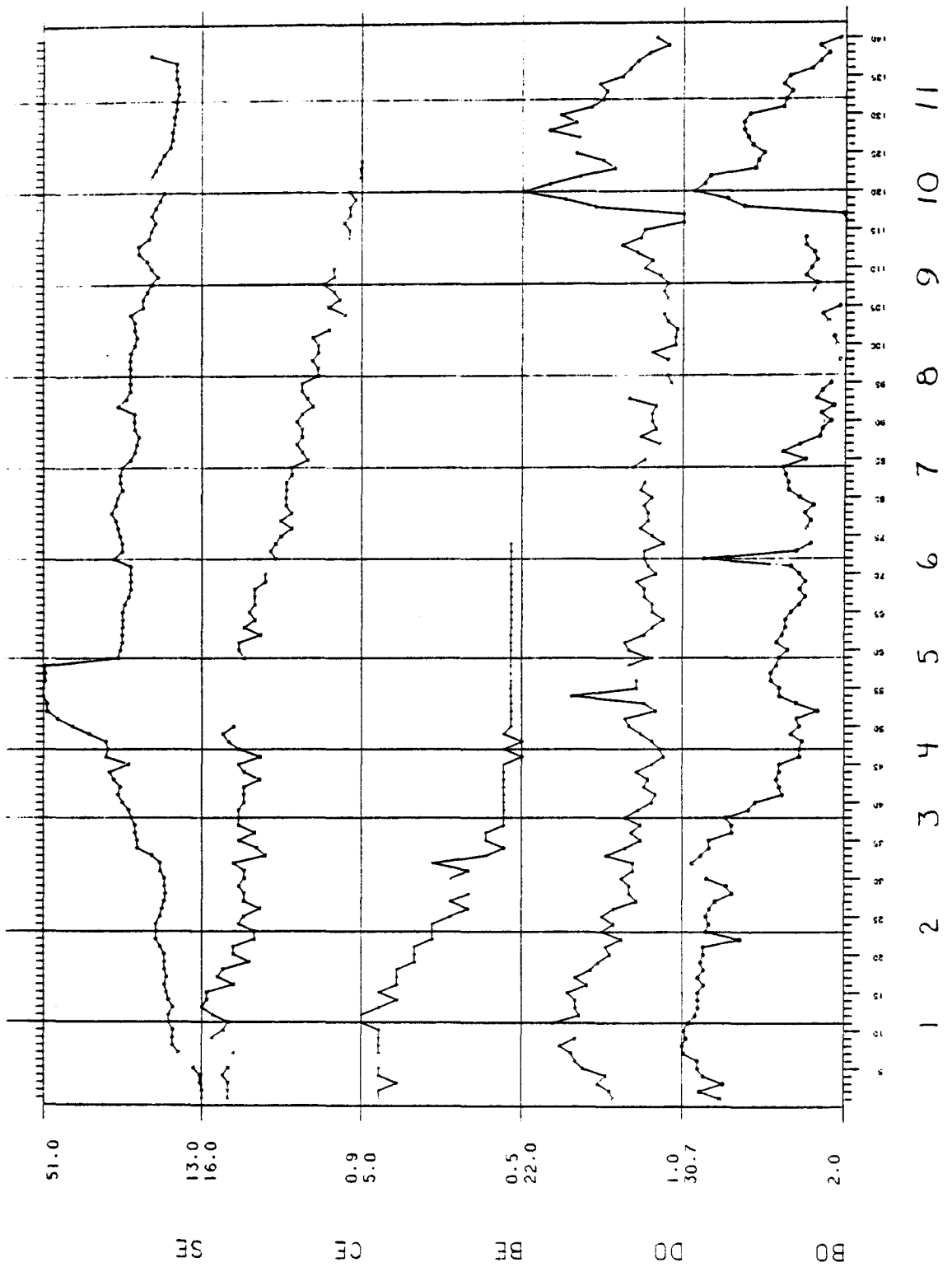

Figure 27 Computer plot of drug and ion effects on various components of the ERG and ONP (constant volume perfusion and sucrose gap recordings)

SE = standing potential of the eye  
 DE = c-wave amplitude (ERG)  
 BE = b-wave amplitude (ERG)  
 DO = "d"-wave amplitude (ONP)  
 BO = "b"-wave amplitude (ONP)

(1) Sham-distilled water	(7) GABA	$1 \times 10^{-3}M$
(2) $K^+$ $4 \times 10^{-3}M$	(8) Histamine	$1 \times 10^{-3}M$
(3) $Ca^{++}$ $2 \times 10^{-4}M$	(9) 1-DOPA	$1 \times 10^{-3}M$
(4) NE $1 \times 10^{-3}M$	(10) Dopamine	$1 \times 10^{-3}M$
(5) 5HT $1 \times 10^{-3}M$	(11) Glycine	$1 \times 10^{-3}M$
(6) ACh $1 \times 10^{-3}M$		

SE rises slightly with (1) is depressed by (2) rises with (3). Rises sharply and characteristically with (4), is depressed by (5), elevated slightly by (6), falls transiently with (7), stabilizes, then falls with (8), rises slightly with (9) and (10), stabilizes and swings up with (11).

CE oscillates downward at (1) levels off but varies at (2) and (3), rises at (4) (points omitted by computer). C-wave amplitude falls progressively thereafter.

BE malfunctioning of a.c. amplifiers necessitated obtaining b-wave amplitudes from d.c. record which are at lower amplification.

DO, BO follow essentially parallel time-courses, falls slightly with (1), rises with (2); in BO falls, sharply after (3), rises with (4), falls with (5); (6) produces a sharp peak in BO followed by a fall that recovers. At (7) depression is maximal. (8) and (9) produce a large increase in the amplitudes of both parameters, while (10) clearly depresses both.

---

Explanatory notes for components of computer plots are found in the legend of Figure 23.

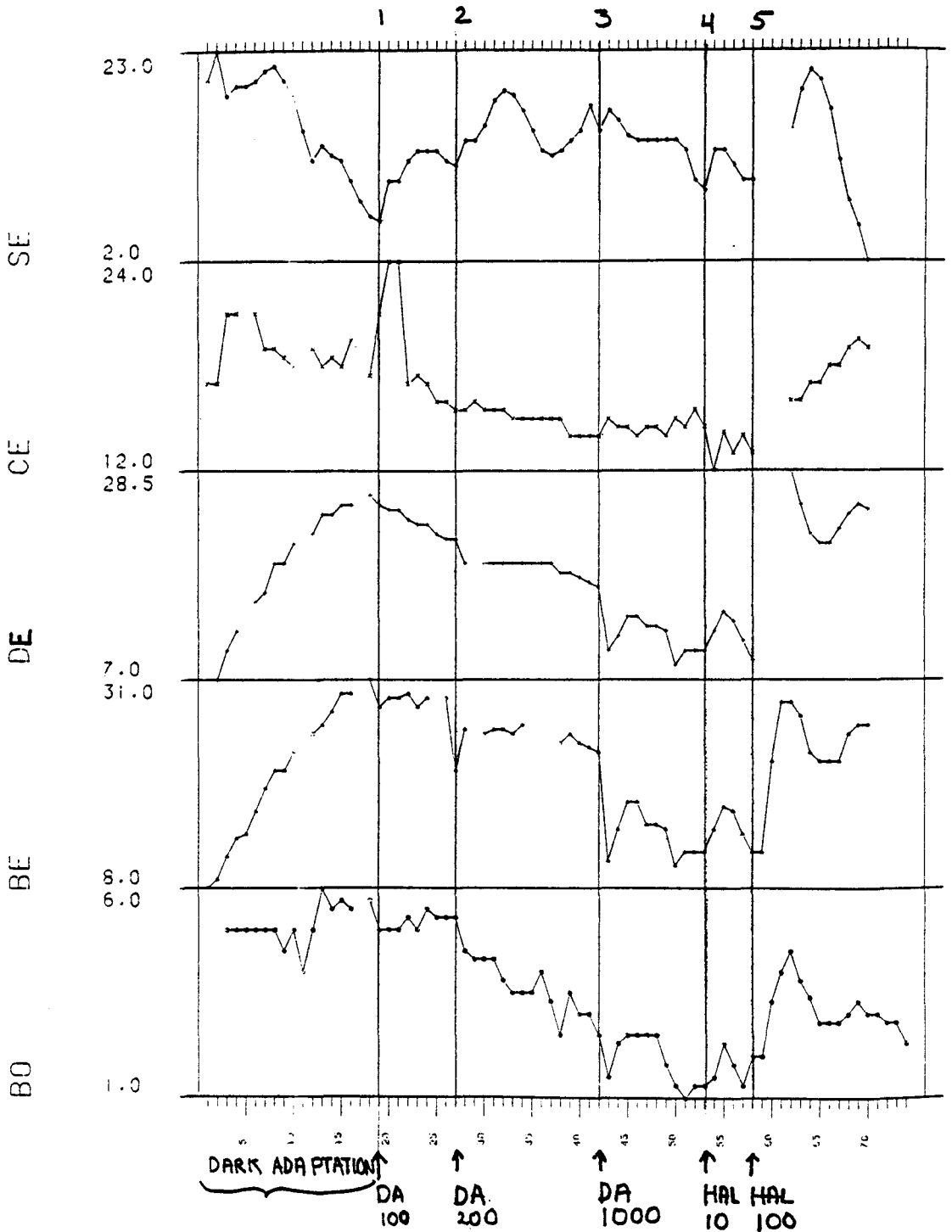

Figure 28 Computer plot of dose-related effects of dopamine and haloperidol a dopamine antagonist on components of the ERG and the "b"-wave of the ONP as a function of time

SE = Standing potential of the eye  
 CE = c-wave amplitude (ERG)  
 DE = d-wave amplitude (ERG)  
 BE = b-wave amplitude (EG)  
 BO = "b"-wave amplitude (ONP)

Dopamine (DA) doses: 100,200, 1000 micrograms/ml td  
 Haloperidol doses: 10,100 micrograms/ml td

Parameters change variously during dark adaptation; SE decreases progressively; DE and BE increase progressively, while CE and BO are variable. SE rises with increasing DA dose, plateauing at the highest dose. The haloperidol effect is biphasic, a rise followed by a fall which is most prominent at the higher dose. CE amplitude rises sharply with the first DA dose, then falls and is further depressed by increasing doses. The higher dose of haloperidol reverses the decline. BE, DE and BO follow parallel time-courses. They are progressively depressed by DA and restored by the higher dose of haloperidol.

---

Explanatory notes for components of computer plots are found in the legend of Figure 23.

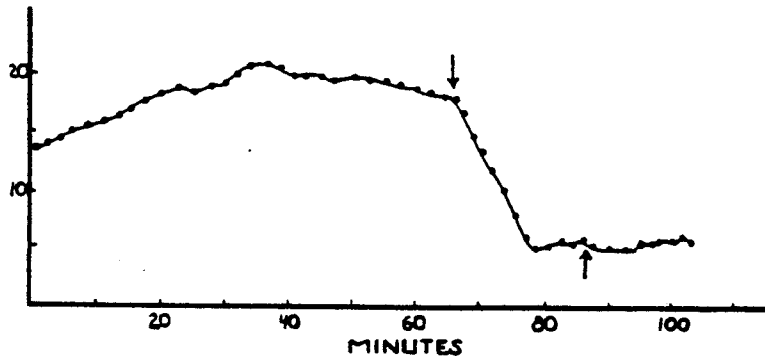

Figure 29 THE EFFECT OF PERFUSED DOPAMINE  
ON b-WAVE AMPLITUDE OF THE ERG OF THE  
ISOLATED PERFUSED FROG EYE

ORDINATE: b-wave amplitude in mm (calibration: 2mv/cm).  
 ABSCISSA: Perfusion time in minutes. Perfusion rate is  
 7 drops/minute. ERGs are elicited every 100 seconds.  
 The progressive increase in b-wave amplitude denotes  
 dark adaptation which plateaus in about 30 minutes.  
 Dopamine ( $5.29 \times 10^{-6}$ M/ml) is perfused through the eye  
 at the first arrow. At the second arrow perfusion with  
 Sickel's medium only resumes. Maximum depression of  
 the b-wave amplitude to 28% of control occurs 13.3  
 minutes after dopamine perfusion begins. The difference  
 between control and experimental treatment is signifi-  
 cant statistically ( $p < 0.01$ ). Mean b-wave amplitude  
 $\pm$  S.D. for control and dopamine treatment are  $19.1 \pm$   
 $0.7$  and  $8.2 \pm 5.1$  mm, respectively.  $n = 10$ .

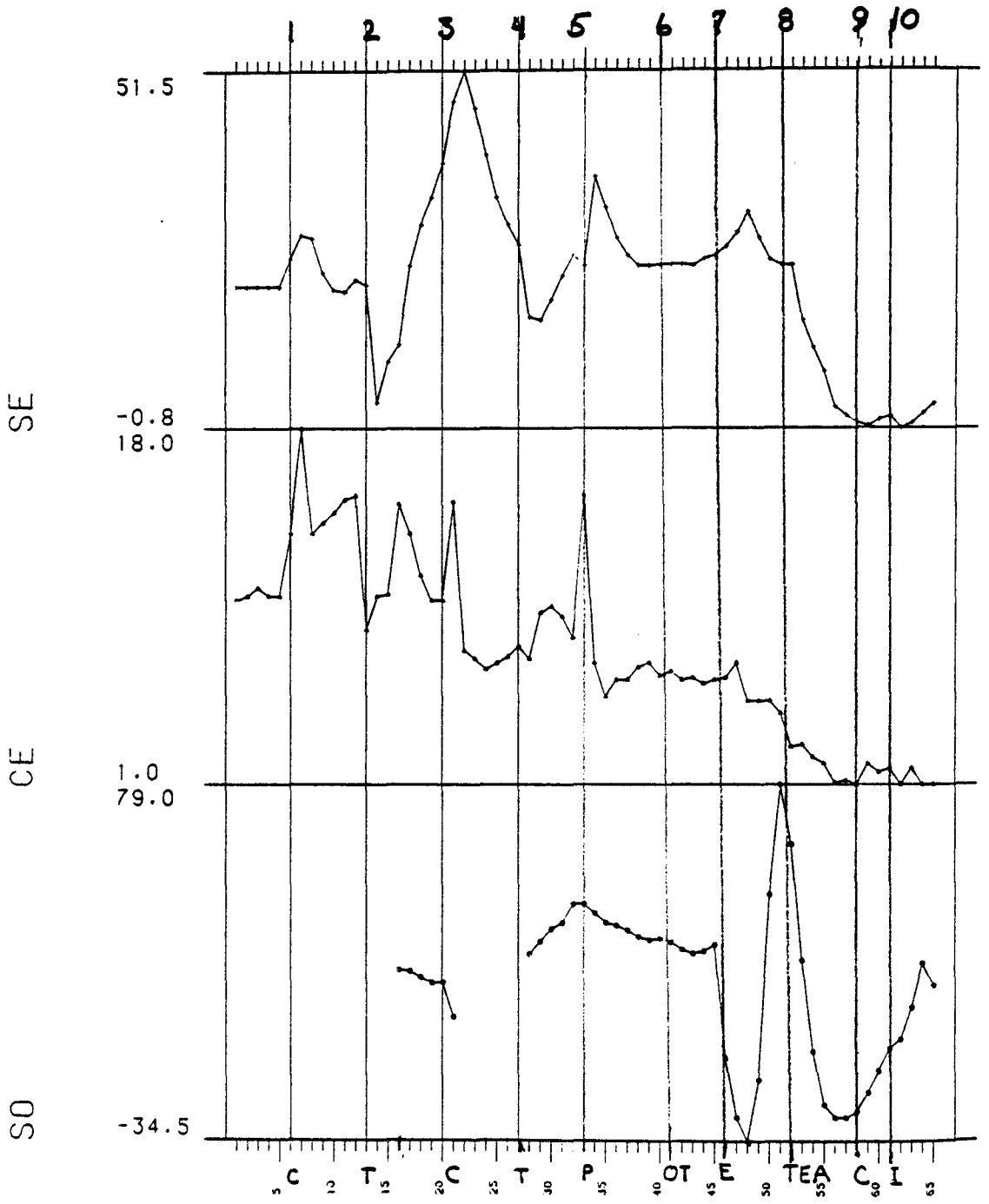

Figure 30 Computer plot of drug effects  
on the standing potential of the ERG and the  
optic nerve and on the amplitude of the c-wave

SE = standing potential of the eye  
SO = standing potential of the optic nerve  
CE = c-wave amplitude (ERG)

(1), (3), (9) carbachol	1.1, 2.7 and 2.7 X 10 <sup>-5</sup> M
(2), (4) tremorine	1.7 and 1.2 X 10 <sup>-3</sup> M
(5) picrotoxin	1.2 X 10 <sup>-3</sup> M
(6) oxotremorine	1.6 X 10 <sup>-3</sup> M
(7) edrophonium	1 X 10 <sup>-2</sup> M
(8) TEA	1 X 10 <sup>-1</sup> M
(10) insulin	1.6 units

SE increases transiently with (1) biphasically with (2). The action of (2) appears to persist during (3) and is depressed during (4), increased by (5) stabilized by (6), increased by (7), fails precipitously with (8); (9) is ineffective. (10)'s action suggests onset of restoration.

CE essentially reflects the changes in SE.

SO also follows this pattern but the effect after (6) is marked especially after (7), (8) and (9).

---

Explanatory notes for components of computer plots are found in the legend of Figure 23.



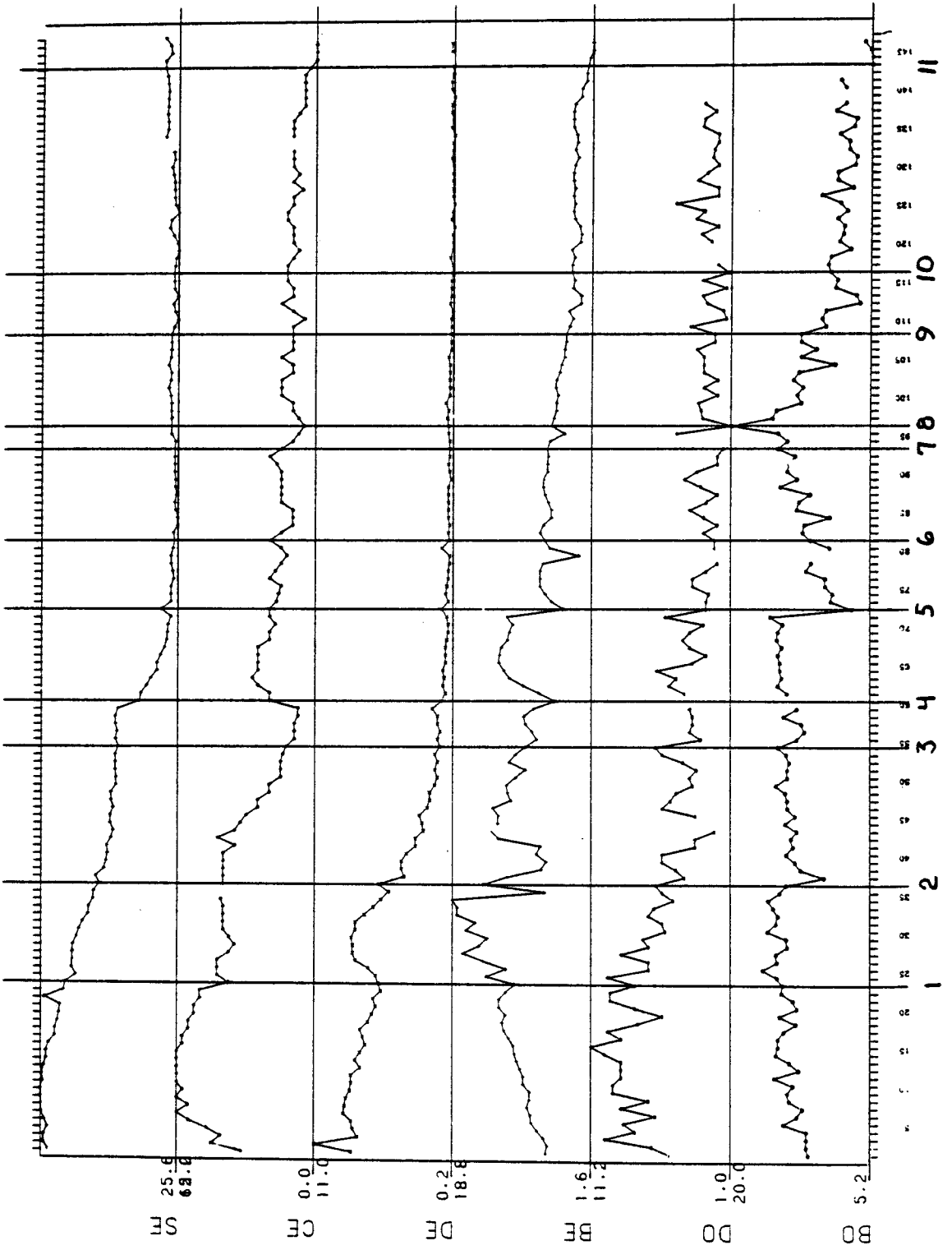

Figure 31 Computer plot of cholinergic drug effects on ERG and ONP components  
Constant volume perfusion and sucrose gap recording of ONP

SE = standing potential of the eye  
CE = c-wave amplitude (ERG)  
DE = d-wave amplitude (ERG)  
BE = b-wave amplitude (ERG)  
DO = "d"-wave amplitude (ONP)  
BO = "b"-wave amplitude (ONP)

- |                   |                              |                                               |
|-------------------|------------------------------|-----------------------------------------------|
| (1) Mecholyl      | 10ml of $1 \times 10^{-4} M$ | (7) Fresh media, addition artifact            |
| (2) Carbachol     | $1 \times 10^{-4} M$         |                                               |
| (3) Hexamethonium | $1 \times 10^{-4} M$         | (8) Mecholyl $1 \times 10^{-4} M$             |
| (4) Mecholyl      | $1 \times 10^{-4} M$         | (9) Carbachol $1 \times 10^{-4} M$            |
| (5) Carbachol     | $1 \times 10^{-4} M$         | (10) $K^{+} 20mM (10 \times \text{Sickel's})$ |
| (6) $ATSO_4$      | $1 \times 10^{-4} M$         | (11) NaAzide $1.5 \times 10^{-2}$             |

SE - negative-going effect of (1), (2), (4), (5) and (6); slight reversal after (7) and (8). Decreases further with (9) and moves in a positive direction after (10). (11) only produces slight change.

CE - is biphasic and decreased after (1), markedly so after (2), slightly more after (3). (4) increases amplitude which diminishes with (5) and is biphasic after (6). (7) now decreases amplitudes, (8) is restorative, (9) and (10) produce a variable relatively-stable state. (11) Does not restore a depressed preparation.

DE - increases with (1) decreases with (2), is unchanged by (3), depressed by (4), (5) and (6), and does not recover subsequently.

BE - in control period increases in amplitude, indicating it is not fully dark-adapted. It is augmented by (1) and (4), biphasic after (2) with initial reduction in amplitude. It follows a trend line with (3). The biphasic effect of (5) begins with an increase in amplitude. Stabilization occurs with (6). The trend line is now in a downward direction with increasing depression at (9) and stabilization at (10).

DO - tends to oscillate. It decreases with (1), is biphasic with (2) and (5) decreased by (3), augmented by (4) and (6), stabilized by (8), decreased by (9) and partly restored by (10).

Figure 31 (Cont'd).

BO - augments with (1), (4) and (6) and is biphasic with (5) and (8), decreased by (3) and (9) and stabilized by (10). Like DO activity is oscillatory.

NB: Left top of SE scale should read 65.0 (Calcomp error).

---

Explanatory notes for components of computer plots are found in the legend of Figure 23.



Figure 32 Computer plot of drug-related effects on components of the ERG and ONP

SE = standing potential of the eye  
 CE = the c-wave (ERG)  
 DE = the d-wave (ERG)  
 BE = the b-wave (ERG)  
 DO = the "d"-wave (ONP)  
 BO = the "b"-wave (ONP)

- (1), (2) GABA  $5 \times 10^{-4}$ M (perfusion period)  
 (3) GABA  $5 \times 10^{-4}$ M perfusion 20ml  
 (4) DA  $5 \times 10^{-4}$ M perfusion 20 ml  
 (5), (6) ACh  $3 \times 10^{-4}$ M (perfusion period)

SE After a 2nd perfusion period with GABA, the standing potential rises significantly. DA (4) augments it. After (5), (6) transient decrease is followed by stability until an upsurge occurs in the last 33 minutes of the experiment. CE undergoes continuous depression after (1), (2), (3) augment prior to and just after (4) BE b-wave amplitudes decrease after (2) and (3) transiently maintained then depressed after (4); continue to decrease after (5).

DO, BO following (1), (2) large amplitude oscillations occur with a period of ca. 10 min. At (3) they augment in amplitude and the period extends by about 50% to ca. 15-16 minutes. The oscillations which decrease during washout are further enhanced after (4). Following the perfusion of (5) the oscillations diminish and the amplitudes and to a lesser extent DO stabilize at a high level.

NB: Vertical lines prior to (2) excluding treatment lines are the result of different monochromatic light stimuli.

---

Explanatory notes for components of computer plots are found in the legend of Figure 23.

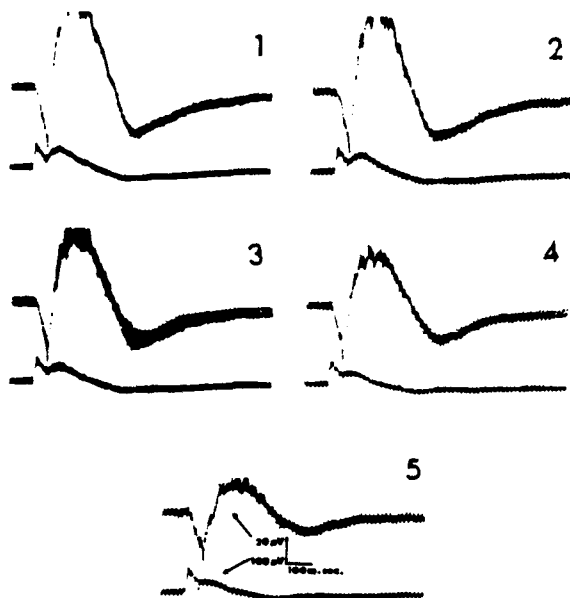

Figure 33 The effect of GABA on the b-wave (ERG) and the late component of the optic nerve potential

The upper trace in 1 shows a fully-developed dark-adapted ERG elicited by a very short duration (10  $\mu$  sec.) xenon flash. The a-wave amplitude is 50  $\mu$ V, b-wave amplitude is 120  $\mu$ V. Approximately 100 milliseconds after the stimulus two prominent peaks can be seen in the optic nerve response (lower trace), an early component, which rises sharply soon after the stimulus, followed by a late component, which peaks. The early and late components of the optic nerve reflect the simultaneous activation by a very brief stimulus of the cones. The early component represents cones and the late component rods which have a longer response latency after stimulation. The early and late component reflect neuronal processing occurring in the retina. (It is not meant to suggest here that there is a direct connection between the photoreceptors and optic nerve).

Upper trace 2 is an ERG 15 minutes after the initial control indicating stability of responses. GABA was given in split doses totalling  $4.8 \times 10^{-3}M$  before 3 and 5. A progressive reduction in b-wave amplitude and late component of the optic nerve to approximately half the control values occurs. This effect simulates features of a light-adapted ERG.

In other experiments (not shown here) the effects of endogenous retinal GABA and exogenously-applied GABA, were antagonized by bicuculline at doses of  $3.3 \times 10^{-4}M$ .

The d-wave amplitude which is considerably smaller than the b-wave, generally parallels the behavior of the b-wave. This is seen most clearly in Figure 28 during dark-adaptation wherein the curves are in almost perfect concordance. The amplitude increases at doses of NE as low as  $2.5 \times 10^{-5} \text{M}$  (Figures 24,25). In Figure 23, however, the overall effect is one of depression of the d-wave. The standing potential of the optic nerve generally moves in a negative-going direction in a dose-related fashion (Table IV, Figure 23). In 4/5 other experiments this effect occurs with single doses of NE (cf. Figures 24, 25, 26). Phenoxybenzamine does not impede the negative-going direction of the standing potential of the optic nerve, but appears to enhance it. It also increased  $dv/dt$  for the ONP SP (see Table IV). In constant pressure preparations in which flow rates vary, NE decreased the flow rate (Figure 26). The behavior of the amplitudes of the "d" and "b" waves of the ONP also parallel each other in response to NE. Their amplitudes, overall, increase significantly (cf. aforementioned figures and especially Table IV). Phenoxybenzamine triggers a long period oscillation in these parameters of the ONP.

### Epinephrine

Epinephrine  $3.1 \times 10^{-5} \text{M}$  was assessed in 3 preparations none of which were naive. The SP of the eye after this

TABLE IV DOSE RELATED EFFECTS OF NOREPINEPHRINE

NE (MOLES)		10 <sup>-5</sup>	5 x 10 <sup>-5</sup>	10 <sup>-4</sup>	5 x 10 <sup>-4</sup>	10 <sup>-3</sup>	PHENOXY-BENZAM. 10 <sup>-3</sup>	10 <sup>-3</sup>
AC ERG	CONTROL							
B-WAVE	16.7 <sup>±</sup> 0.4 (16.2-17.2)	18.2 <sup>±</sup> 0.5 (17-19)	19.1 <sup>±</sup> 0.8 (18-19.8)	18.1 <sup>±</sup> 0.7 (17-18.8)	15.8 <sup>±</sup> 1.1 (13.8-17.2)	11.7 <sup>±</sup> 1.2 (9.8-13)	7.3 <sup>±</sup> 1.9 (5.4-9.5)	4.5 <sup>±</sup> 0.2 (4.2-4.8)
D-WAVE	4.1 <sup>±</sup> 0.4 (3.8-4.8)	3.5 <sup>±</sup> 0.4 (3.1-4)	3.0 <sup>±</sup> 0.2 2.6-3.1	3.1 <sup>±</sup> 0.3 (2.8-3.6)	2.6 <sup>±</sup> 0.5 (2.1-3.8)	2.0 <sup>±</sup> 0.5 (1.4-2.8)	1.3 <sup>±</sup> 0.3 (1-2)	1.2 <sup>±</sup> 0.3 (1-2)
DC ERG								
C WAVE	10.0 <sup>±</sup> 0.3 (9.5-10.4)	10.9 <sup>±</sup> 0.4 (10-11.4)	11.4 <sup>±</sup> 0.4 (10.9-11.8)	10.4 <sup>±</sup> 0.4 (10.9-12.2)	10.3 <sup>±</sup> 0.7 (10-12)	10.8 <sup>±</sup> 0.4 (9.8-11)	8.8 <sup>±</sup> 0.3 (8.2-9.4)	8.1 <sup>±</sup> 0.1 (8-8.2)
AC ONP								
B-WAVE	15.2 <sup>±</sup> 0.5 (14.1-16.2)	18.3 <sup>±</sup> 1.3 (16.6-20.5)	21.7 <sup>±</sup> 1.3 (19.5-23.6)	21.9 <sup>±</sup> 2.2 (17.4-23.8)	23.5 <sup>±</sup> 0.9 (22.3-25)	24.4 <sup>±</sup> 1.4 (23-26.9)	15.1 <sup>±</sup> .39 (6.6-17.8)	16.7 <sup>±</sup> 1.5 (15-19)
D-WAVE	2.6 <sup>±</sup> 0.5	2.8 <sup>±</sup> 0.3	3.5 <sup>±</sup> 0.6	4.0 <sup>±</sup> 0.3	6.4 <sup>±</sup> 1.1	8.8 <sup>±</sup> 0.6	8.0 <sup>±</sup> 2.2* (3.3-16.2)	5.8 <sup>±</sup> 0.4 (5.4-6.5)
S.P.								
ERG	27.9 <sup>±</sup> 0.6	29.7 <sup>±</sup> 0.7	31.3 <sup>±</sup> 0.5	33.4 <sup>±</sup> 0.6	34.9 <sup>±</sup> 0.7	34.6 <sup>±</sup> 0.5	34.4 <sup>±</sup> 1.0	35.0 <sup>±</sup> 0.8
ONP	34.6 <sup>±</sup> 9.5	10.4 <sup>±</sup> 5.1	6.3 <sup>±</sup> 1.6	11.6 <sup>±</sup> 4.9	27.3 <sup>±</sup> 1.0	31.7 <sup>±</sup> 2.5	42.9 <sup>±</sup> 3.8	51.0 <sup>±</sup> 1.0
DV/DT ONP S.P. (IN MV/MIN.)	~1.0 <sup>†</sup>	stable	0.3 <sup>†</sup>	0.3 <sup>†</sup>	0.75 <sup>†</sup>	0.22 <sup>†</sup>	0.41 <sup>†</sup>	-

PARENTHESSES ENCLOSE RANGE OF VALUES  
 UNITS UNLESS OTHERWISE STATED ARE ARBITRARY  
 N: RANGES FROM 5-12

\*BIPHASIC: DECREASES, THEN INCREASES, THEN DECREASES



catecholamine in contrast to NE, moved in a negative direction in all three preparations. The SP of the optic nerve also moved in a negative direction. The amplitudes of the b- and d-waves generally increase although in one preparation multiple doses depressed the b-wave. In one experiment the a-wave amplitude increased. The "b"-wave of the optic nerve increased in amplitude while the "d"-wave amplitude diminished.

### Dopamine

Dopamine was evaluated in 10 perfused eye preparations in concentrations ranging from  $2.6 \times 10^{-5} \text{M}$  to  $10^{-3} \text{M}$ . In some of these preparations, haloperidol, a dopamine antagonist, was also perfused in concentrations ranging from  $2.7 \times 10^{-5}$  to  $2.7 \times 10^{-4} \text{M}$ . The experiment depicted in the computer plot in Figure 28 is a good representation of some of the effects dopamine exerts on the isolated perfused frog eye.

As the b- and d-wave amplitudes build up during dark-adaptation the SP of the eye diminishes. After DA the SP builds up in a dose related fashion until a concentration of  $10^{-3} \text{M}$  is reached. Then the SP stabilizes. Haloperidol at  $2.7 \times 10^{-5} \text{M}$  is relatively-ineffective in restoring the SP, but ten times this dose brings a rapid sharp rise in the SP followed by a fall. The c-wave amplitude initially is augmented by DA, then becomes depressed. This occurred

in 8/8 preparations in which good c-waves were recorded. The b-wave amplitude changes parallel those of the d-wave. An example of b-wave depression by dopamine is seen in Figure 29. The depression of b- and d-waves by dopamine is clearly dose-dependent (cf. panels 1, 2 and 3, Figure 28). The restoration of amplitude by the high dose of haloperidol is prompt. The effect of DA on SP of the optic nerve is variable and dose-dependent. Low doses tend to move it in a positive direction, higher doses, toward the negative; "b" wave amplitude of the optic nerve is depressed in most preparations (cf. Figure 28). Optic nerve "d"-wave effects tend to parallel those of the "b"-wave. A positive-going effect on the optic nerve and a negative-going effect on the eye was already seen in the photically-unstimulated dark-adapted eye as was the enhancement of spiking activity recorded in the optic nerve. Not unexpectedly dopamine increased flow rates in the vasculature of the eye (cf. Figure 26).

### GABA

GABA was studied under various experimental conditions in early and more recent experiments. In early studies stroboscopic flash was used as a stimulus to elicit the ERG. An example is shown in Figure 33, which depicts b-wave depression by  $4.8 \times 10^{-3}$  M GABA. Subsequent studies used incandescent light pulses of 10 seconds duration as stimuli.

Only one of 7 preparations was naive (cf. Figure 32). In 4/7 the SP of the eye became more positive. This is clearly seen in Figure 32 after the second perfusion of  $5 \times 10^{-4}$  M GABA. The c-wave was depressed in 6/7 preparations (cf. Figures 26, 27 and especially 32). The b- and d-wave amplitudes were depressed in a majority of preparations, sometimes the effect seen was biphasic (compare Figures 32 and 26). In half the preparations in which the standing potential of the optic nerve was recorded the preparation becomes more negative. A positive-going SP occurred when the highest dose of GABA ( $1 \times 10^{-3}$  M) was used (Figure 26). A rather striking effect was uncovered with respect to the "b"- and "d"-waves of the ONP. After perfusion with  $5 \times 10^{-4}$  M GABA in a naive preparation, their amplitudes developed long-term oscillatory activity (Figure 32). Amplitudes increased and decreased with a period of about 10 minutes. The period lengthened with subsequent doses of GABA. These long-period oscillations were further modified by dopamine and finally terminated by acetylcholine.

### Picrotoxin

Picrotoxin, a GABA antagonist, was used in three preparations that were not naive. Figure 30 represents one of these: SP (eye) moves in a positive-going direction in 3/3 preparations. C-wave amplitude changes are biphasic rising initially and falling sharply. Multiple doses used

in another experiment (not illustrated) indicate the possibility of tachyphylaxis in that these effects were reversed after three doses of the same size. SP (optic nerve) moves in a positive direction (downward by convention). B- and d-waves augment in a parallel fashion.

### Glycine

Glycine in doses of  $2.7 \times 10^{-4}M$  to  $10^{-3}M$  was always given late in an experiment, in essence to a deteriorated overly-challenged preparation, so that the reliability of the glycine data generated is suspect. As a generalization, for five preparations, the SP of the eye became positive e.g., Figure 26) or displayed biphasic action at first moving in a positive direction followed by a change to negative. The c-wave amplitude is depressed but stabilized. The b-wave is enhanced at a low dose, depressed at a high dose. The SP of the optic nerve like the "b" and "d"-wave of the ONP are more frequently reduced than augmented, i.e., the SP becomes more positive and the amplitudes are smaller.

### Strychnine

Strychnine, a glycine and taurine antagonist, at doses ranging from  $1.2 \times 10^{-5}M$  to  $2.3 \times 10^{-4}M$  produced effects illustrated in Figures 24 and 25. The SP (eye) moves in a negative direction (Figure 24). The c-wave is slightly depressed while b- and d-waves are clearly depressed in (Figure 24) but tend to increase in (Figure 25). Opposite

effects are seen in these figures with respect to SP (optic nerve).

### Histamine

Histamine was administered to five preparations but not to naive preparations in doses ranging from  $5.4 \times 10^{-5}M$  to  $10^{-3}M$ . The SP of the eye generally moved in a negative direction and that of the optic nerve in a positive direction. Biphasic activity in these responses was not unusual. The c-wave amplitude was usually depressed (Figure 27) but sometime showed oscillatory activity (Figure 26). B- and d-waves of the ERG decreased in amplitude at  $5.4 \times 10^{-5}M$  and were increased at the higher doses. Effects on these parameters parallel each other. ONP "b" and "d"-waves are variable but parallel each other in their responses. In one experiment at a-wave threshold, histamine ( $5.4 \times 10^{-5}M$ ) initially augmented and then depressed a-wave amplitude. Blood flow in a constant pressure system increased after histamine  $1 \times 10^{-3}M$  (Figure 26).

### Serotonin

Serotonin (5-HT) was evaluated in 4 preparations, none of which were naive. Given just after NE, effects seen are often confounded with those of NE. The SPs of the eye usually augmented (Figure 26) but under constant volume perfusion, 5-HT produced an SP that moved in a negative direction. The c-wave amplitude usually decreased after an

initial increase (Figure 25) b-wave amplitude was reduced (cf. B1 in Figure 25) while d-wave effects were variable. The a-wave in one eye became depressed by a dose of  $2.3 \times 10^{-5}$ M. The SP of the optic nerve moved in a negative direction. The example in Figure 26 is biphasic - the "b" and "d" components of the ONP are not easily characterizable except that they are multiphasic and overall are slightly depressed.

### Cholinergic Drugs

An interrelated group of a dozen drugs acting at muscarinic and nicotinic receptors were examined with respect to their effects on the isolated perfused eye preparation. These include acetylcholine, methacholine, Carbachol, nicotine, TEA, hexamethonium, edrophonium, tremorine, oxotremorine, neostigmine, d-tubocurarine and atropine. Results for the last five are to be found in Appendix D.

### ACh

ACh was perfused in ten preparations in doses of  $5.5 \times 10^{-6}$  to  $1.4 \times 10^{-3}$ M. Figures 22, 24, 25, 26 and 32 illustrate and describe effects obtained. In three naive preparations the SP of the eye is depressed (Figure 24), while in non-naive preparations it moved in either direction (Figures 25, 27, and 32). The SP of the optic nerve tends to be depressed especially in naive eyes, b-wave as well as ONP "b"-wave augmentation occur more frequently,

than depression, while d-wave and ONP "d"-wave changes are more diverse. C-wave amplitude is usually reduced.

### Mecholyl

Figure 31 illustrates the effects of Mecholyl  $10^{-4}M$ , in a naive eye. The SP (eye) initially more positive becomes negative. The c-wave, b- and d-wave, augment. The "b"-wave increases while "d"-waves diminish. The SP of the optic nerve moves in a negative direction (negative, by convention, is up for optic nerve).

### Carbachol

At a dose of  $10^{-4}M$  Carbachol, in a preparation that had previously received a single dose of Mecholyl (Figure 31) decreases SP (eye) positivity and c-, d-, "b", and "d"-wave amplitudes. B-wave amplitudes increase while SP (optic nerve) (not plotted) becomes positive. In a naive eye (Figure 30) the SP is clearly biphasic and the c-wave augments.

### Edrophonium

This drug, at the high dose of  $10^{-2}M$  produces a marked biphasic effect (Figure 30) especially on its second leg when the SP (optic) rises spectacularly. This is accompanied by smaller biphasic effects on the SP (eye) and c-wave.

### TEA and Hexamethonium (C-6)

In the same figure,  $10^{-1}M$  moves the SP (eye) in a negative-going direction, the SP (optic nerve) in a positive-

going direction and all but eliminates c-wave responses. Similar effects were seen in two other preparations at considerably lower doses of  $1.2 \times 10^{-4} \text{M}$ . C-6 at  $10^{-4} \text{M}$  also moves the SP (eye) in a negative direction, depresses the c-, b- and d-wave and moves the SP (optic) in a positive direction. Figure 31 depicts C-6 activity in an eye that is not naive. The SP (eye) decreases as does c-, b-, "d"- and "b"-wave. Interestingly, the SP (eye) becomes much more positive after perfusion ceases. There is a remarkable rebound increase in c- and b-wave amplitude.

#### Nicotine

At doses of  $6.7 \times 10^{-5} \text{M}$  to  $10^{-4} \text{M}$ , nicotine in non-naive eyes produces variable effects on SP (eye) and c-wave amplitude. The b-wave and usually the d-wave are augmented. SP (optic nerve) is also variable, but the "b"-wave tends to increase in amplitude. In a single preparation  $6.7 \times 10^{-5} \text{M}$  increases a-wave amplitude.



## GENERAL DISCUSSION

The isolated perfused frog eye preparation was developed in order to enable an investigator to examine, under carefully-controlled conditions, underlying ocular processes principally in the retina that subserve visual and light-mediated functions in the central nervous system. This study represents the first step toward that goal.

Approximately 15% of the retina is specialized for photoreception, the rest is analogous to the grey matter of the brain (Graham, 1974). Retinas are classified on the basis of ganglion cell organization and function as simple (man) or complex (frog, pigeon) (Dowling, 1970). While the retinas of vertebrates differ in some details from species to species the overall design of structure and cellular elements have common features which allow for interspecies comparisons when subjected to physiological study (Armington, 1974). The frog eye has been studied extensively since the very beginning of electrophysiological investigations (DuBois-Reymond, 1849). DuBois-Reymond's preparation, the excised eye can yield "normal" responses for a relatively-brief time following enucleation. A major disadvantage of this preparation is that it lacks the supportive elements necessary to maintain prolonged homeostasis since no circulatory fluid

is used. In vivo preparations are often unsatisfactory due to the presence of reflex activity originating in the CNS and artifacts arising from the activities of the cardiovascular system. Substances are present in blood (e.g. hormones, ions, amino acids, etc.) which further complicate experimental design and makes interpretation of results more difficult. In vitro systems, while extremely important and useful (Ames & Pollen, 1969; Brindley, 1956 a,b,c,d; Ottoson & Svaetichin, 1953, etc.), also have major deficiencies.

The neural retina is separated from the pigment epithelium layer, which plays an important role in photoreceptor function. In addition, the retina must be nourished by diffusion of materials from its surface to deeper layers, preventing easy separation of inflow from outflow and producing an uneven and undoubtedly abnormal distribution of metabolites in thicker areas of this actively metabolizing tissue. Also, a certain amount of damage must inevitably occur whenever the entire retina or a fragment of it is removed from the eye (Gouras & Hoff, 1970).

Thus isolated, retina and eye cup preparations (Kramer, 1971) which generated much important and useful information, still suffer from absence of parts of the "black-box" that are present in the intact eye.

Küchler et al., (1956) obtained ERG's from the incubated intact frog eye for 14 hours by maintaining the eye in an atmosphere of 100% oxygen. Its circulatory system was not used. Wong & Macri (1964) did the first vascular perfusion of the enucleated mammalian eye. They studied

aqueous humor dynamics. O'Rourke and Berghoffer (1966) used heparinized whole blood in the isolated perfused canine eye to examine uveal tissue respiration. Gouras & Hoff (1970) adapted Macri's technique to study electrophysiological function in the cat eye. Using Eagle's (1959) tissue culture medium with calf serum their preparation lasted as long as 10 hours. Tazawa et al., (1969, 1971, 1972, 1977), Imaizumi et al., (1972, 1974) and Seamen et al., (1965, 1969, 1971) studied the effects of anoxia and hypothermia of the ERG as well as CO<sub>2</sub> elaboration and glucose consumption of the isolated perfused (whole, heparinized blood) bovine eye. They also looked at intravascular hemagglutination and thrombosis in this system. Modification and further development of Gouras' technique with the cat eye is described in a series of papers by Niemeyer & Gouras (1973) and by Niemeyer (1975, 1976). The retinal physiology of this eye was studied and the preparation was proposed as a model system to be used in neurobiologic research (Niemeyer, 1977).

Marchese and Friedman (1973a) were the first to report the use of the isolated perfused frog eye as an experimental paradigm for retinal function studies. At that FASEB meeting in Atlantic City, N.J. they also introduced their new technique of time-lapse electroretinography. The retina of the frog eye was one of the first to be studied using electrophysiological methods. Its behavior when dark-adapted

is like that of the E retina (rod-dominant). Oscillatory or ripple-like activity of the b-wave can occur (Granit & Munsterhjelm, 1937) suggesting photopic activity. Some of the properties of the frog eye, e.g., "rod-cone" break, spectral shift and difference of wave shape in the dark vs. the light adapted ERG are similar to the human eye (Armington, 1974). However, the retina of the frog has its own set of unique characteristics (green rods, complex inner retinal organization, etc.) and differs from that of the human (Dowling, 1968). The retina of the cat is mainly of the scotopic type reacting thusly over low to moderate levels of stimulation (Armington, 1974). The cat retina also has a simple type inner plexiform layer organization like that of the human. While a mammalian retina might be preferred as an experimental tool, over the amphibian, a major disadvantage when recording the SP is the occurrence of oscillations. Knave et al., (1974 a&b) studied the effect of barbiturates on the ERG of the intact sheep eye. Their technique included the use of low drift d.c. recording. They noted that thiopental at doses (>10 mg/kg) resulted in negative-positive cyclic variations resembling damped-oscillations. Damped-oscillations in the human EOG were reported by Täumer et al., (1974) and in the directly-recorded ERG of the human by Skoog (1974). The report by Kikawada (1968) that the frog eye does not exhibit such a cyclic

variation of S.P. suggested the usefulness of this animal for long term isolated perfused eye experiments. Recently Lurie (1973, 1976), using d.c. recording techniques, has explored in situ, in the frog, the effects of the c-wave and/or c-process (alterations of SP) on class IV neurons (Maturana et al., 1960) in the optic nerve "in their entirety". He found that the patterns of neuronal discharge in these optic nerve fibers (dimming fibers) encoded the log quantal content of the light flashes and that modulation in ganglion cell activity is causally-related to the transretinal current associated with the c-wave.

The lability of the standing potential of the eye and optic nerve in response to drugs is clearly seen in the results (cf. Summary, items 16 through 37).

The standing potential recorded from the ERG electrodes measures activity originating from the inner limiting membrane to the R-membrane (Brindley, 1956). The term, standing potential, has been used interchangeably with steady-potential (Ottoson & Svaetichin, 1952; Noell, 1953; Brindley, 1956a) resting-potential (Brindley, 1956a) and slow-voltage, (Lurie, 1973).

The relationship of the c-wave to the standing potential of the eye i.e. the corneal vs. the scleral voltage has never been very clear (Lurie, 1973). The c-wave represents a slow voltage change evoked by a pulse of light,

while the standing potential is the potential measured using the same electrode system irrespective of light stimulation. The c-wave encodes the log-quantal content of the light used as a stimulus whereas the standing potential includes this and other intraocular ongoing processes. Variations of the SP result from epiphenomena occurring in the globe other than the voltage resulting from Gibbs-Donnan activity in the eye. Sano et al., (1967) subdivides steady-potentials recorded from the human scalp or skull into two categories. The first one, the SP occurs in the millivolt range and is stable as the name implies. "It shows little or no change on various external stimulations or during various cerebral activities." The second, which they term the slowly-changing potential (SCP) displays values which range from 50 microvolts to several millivolts. The latter more nearly reflects the type of activity generated within the eye and optic nerve which in the present study is called the standing potential. The former reflects the Gibbs-Donnan equilibrium.

Orkand, Kuffler and Nichols (1966) pointed out that membrane potentials recorded in the optic nerve are a reflection of glial activity. Glial (Müller cells) within the retina are influenced by neuronal activity (Dowling & Werblin, 1969). Somjen (1973) states that evidence favors the hypothesis that SP shifts are evoked by repetitive

stimulation of different nerves or of fiber tracts. But he indicates that there is no convincing reason to suggest that neurons are influenced by sustained currents flowing in the extracellular medium.

Schmitt, et al., (1976); however, state that neuronal local circuits are influenced significantly by characteristics of the cell membrane and by changes of ionic environment or extracellular electric fields. Thus, d.c. recordings would reflect neuronal excitation processes even if the steady potential is generated in part by glial membranes.

Neuronal activity in optic nerve axons is initiated by ganglion cell discharges when the eye is stimulated by light. The active optic nerve axons liberate potassium into intracellular clefts. Glial cells surrounding these axons respond to the accumulation of potassium by depolarization of the membrane. A flash of light 100 msec in duration caused a glial cell response lasting many seconds (Orkand et al., 1966). Considerably more sophisticated studies must be employed to bring the phenomena observed beyond its current descriptive stage to one that can explain underlying mechanisms.

Knighton, (1975) probed the properties of response of the frog eyecup preparation using electrical instead of light stimulation. Brief pulses of current were used which

evoked a response he called the electrically-evoked ERG (EERG). The origin of this response appears to be the same as the PII, i.e., the b-wave intraretinally. Using trans-retinal d.c. polarization he was able to modify the amplitude and wave-form of the frog's ERG. Outward current depresses while inward current (sclera to vitreous) enhances the ERG.

The isolated perfused eye preparation is useful in the study of basic retinal physiology. Results obtained from isolated eyes compare favorably with in vivo experiments. Discrete wavelength stimulation in the visible, near ultraviolet and near infrared regions of the spectrum was performed in the laboratory on the isolated eye, the curarized in vivo eye and the human in vivo. The potential changes obtained using higher visible wavelengths is substantially in agreement with the established sensitivity curves (Dartnall, 1953). Spectral sensitivity data for the SP of the eye does not usually include data obtained below 400 nm (ultraviolet) nor greater than 660 nm (infrared). Our experiments (Fig. 18) have shown a sensitivity of the curarized eye and isolated perfused eye to near UV that is greater than expected. In fact, this laboratory reported (Maggiano, Marchese & Friedman, 1975) the response of the human EOG to 365 nm stimulation to be 550 times greater than could be predicted by extrapolation of the CIE Scotopic



sensitivity curve at 380 nm (Elenius & Lehtonen, 1962). The unexpectedly-high response at a region of the spectrum not used for vision suggests the existence of another channel for transmitting information to the CNS. There is a high ambient level of near UV wavelengths present in the environment in daylight and in various sources of artificial illumination which might exert a tonic influence on the gain-setting mechanism (Rushton, 1965) of the eye. Ozaki & Wurtman (1979) report that the offspring of pregnant rats exposed to light from high-pressure sodium vapor bulbs (monochromatic yellow) weighed more during early development and had larger adrenal glands than animals raised under fluorescent lamps with a daylight-like spectrum. They suggest that these data are evidence that the spectral quality of light is a major determinant for mammalian growth and development and that the pathway involved is mediated by specialized retinal photoreceptors impinging on neural or neuroendocrine communication networks.

Exploration of the electrophysiological effects of the spectrum has potential clinical usefulness. Chloroquine, an antimalarial drug used in the treatment of arthritis, is concentrated in the retinal pigment epithelial cells where it produces a severe nonreversible retinopathy. (Meier-Ruge, 1972; Potts & Gonason, 1975). The presence of a zone of depigmentation encircling the macula seen ophthalmoscopically

is indicative of a relatively-late stage of the disease process. Electrodiagnostic procedures according to Henkes & Deutman, (1973) facilitate the localization and determine the extent of drug-induced ocular lesions. Others, however, suggest that the ERG, EOG and VER are not particularly useful in the early detection of drug-induced retinopathies. Alfieri & Solé (1968) used "dynamic-electroretinography" in ultraviolet light for the early recognition of chloroquine retinopathy. The isolated perfused eye might be the model system to screen drugs with fluorescent characteristics that accumulate in the retina. Concomitant electrophysiological measurements would enable one to predict the time-course of the retinopathy prior to clinical trials.

Localized within the retina is an extensive array of biogenic amines that have a neurotransmitter function or are suspected to behave this way in other parts of the CNS and/or ANS. Among these are: GABA, glycine, dopamine, acetylcholine, melatonin, serotonin, glutamic acid, aspartic acid together with their synthesizing and metabolizing enzymes and metabolites. The presence of these substances has been determined largely by uptake studies, fluorescence techniques, etc. (Nosaki, 1973; Ehinger, 1970, 1972; Bruun & Ehinger, 1972; Dowling & Ehinger, 1975; Lam, 1972; Kramer, 1971; Kuriyama, et al., 1968; Cardinali & Rosner,

1971; Pomerantz & Sorrentino, 1973; Marshall & Voaden, 1974; O'Steen & Vaughan, 1968). There are a number of reports in the literature demonstrating transmitter activity in the eye, Ames & Pollen, 1969; Murakami et al., 1972; Honda, 1972; Noell, 1959, etc.

The complexity of the inner plexiform layer of the frog retina (Maturana et al., 1960; Dowling, 1968) indicating its tendency toward "encephalization" makes it a good choice for studying the actions of neuropharmacological agents especially because of the variety of synaptic connections possible when as many as four consecutive synapses of the serial type have been observed, (Dowling, 1968; Dowling & Werblin, 1969; Dubin, 1970).

Neuropharmacological studies in isolated perfused eyes are rare. The first, reported by Marchese & Friedman (1973b) showed that GABA, simulating the light-adapted state, reduced the b-wave and slow component of the optic nerve potential of the frog eye (see Fig. 33). Reversal of the actions of GABA was accomplished by using an antagonist, bicuculline. Niemeyer & Cervetto, (1976) reported that atropine (0.1 - 0.5mM) in the cat produced dose-dependent, reversible changes in b-wave amplitude and depressed the ON-effect of the optic nerve response. The latter effect was also dose-dependent and reversible.

The drug effects observed in the course of this investigation should be considered preliminary and not definitive. The state of the art is reflected in the summaries of reviewers in this area.

Based on all of the data on neurotransmitter content and metabolism available at the present time, there has not been any readily identifiable pattern for the different transmitter systems, Graham (1974).

According to Bonting, (1976) "... many questions, uncertainties and problems still (are) facing us."

The literature on retinal pharmacology is in certain respects disappointing. Much of it is descriptive, giving insight neither into the action of the pharmacological agent nor into the physiology of the tissue. Furthermore, the observations are sometimes conflicting and even contradictory, Van Harrevald (1977).

Where insights into underlying mechanisms occur in this study they will be expounded.

The dose-dependent effects produced by NE in the isolated perfused frog eye resemble those reported by Straschill & Perwein (1968, 1969) in the cat and by Ames & Pollen (1969) in the rabbit. Intracarotid NE in the cat enhanced, depressed or produced biphasic responses in the spontaneous unit discharges of the ganglion cells. Spontaneous and light-induced ganglion cell discharges were depressed by iontophoretic application of NE. In the isolated rabbit retina NE enhanced the spontaneous activity of the OFF cells and depressed that of the ON- and ON-OFF cells. The alpha adrenergic blocking agent, phentolamine, reversed these

effects. In the present study, b-wave amplitude varied in a dose-related fashion (Table III, Fig. 23) augmenting at low and decreasing at higher dose levels. The c-wave increased in amplitude at each dose level. Phenoxybenzamine, the alpha adrenergic blocker used in the present study, was ineffective in altering any parameter except the SP of the optic nerve and the "b"- and "d"-waves. The long period oscillations of the "b"- and "d"-waves (Fig. 23) are very similar to those seen in Fig. 32 after GABA was administered to a naive preparation. It is intriguing to find that an alpha adrenergic blocking agent in a preparation well-saturated with NE as the result of consecutive and increasing dosage appears to unmask an effect seen with GABA in a naive preparation. It is well-known that GABA can interact with catecholamines (Yessian et al., 1969) and is capable of mobilizing norepinephrine and dopamine. Whether the reverse is true, i.e., GABA mobilization by NE is not known. However, it has been shown that NE is a potent inhibitor of GAD (glutamic acid decarboxylase), (Wu & Roberts, 1974) and could alter the activity of the GABA synthesizing system.

Epinephrine ( $10^{-3}$ M) moved the standing potential of the eye downward and that of the optic nerve upward. Mita et al., (1969) using a higher dose range than used in the present study obtained similar results in the anesthetized rabbit and cat eye. Epinephrine slightly depressed the

rabbit eye SP at  $10^{-3}$ M and produced a biphasic response at  $10^{-1}$ M which was initiated by a fall in SP. In a range of  $10^{-4}$ M to  $10^{-1}$ M, the SP of the cat eye became progressively more negative. They concluded that the source of the SP was the retinal pigment epithelium and Bruch's membrane and that the Negative and Positive waves were the consequence of an interaction with epinephrine. Therman (1938) as well as Tomita et al., (1951) found that epinephrine depressed the b-wave of the frog ERG. This finding differs from those of the present study but could reflect differences in dose, season and previous drug history of the preparation. The fact that epinephrine occurs in significant amounts in the frog and the toad, Drujan et al., (1965) suggests that epinephrine is involved in the function of the amphibian retina.

Dopamine inhibits spontaneous and light-evoked activity of cat retinal ganglion cells, Straschill & Perwein, (1969). In the case of the latter the latency increased. Dopamine also decreased the activity of ON and ON-OFF cells in the isolated rabbit eye, Ames & Pollen (1969). Inhibition of ERG components is the observed effect in the present study (cf. Figures 28, 29). The ability of haloperidol, a dopamine antagonist, to restore dopamine-depressed activity in the retina is at least an indication that this antagonist acts in the neural retina. The high concentration of dopa-

mine in the retina (Häggendal & Malmfors, 1965), its intimate association with the interplexiform cells of some species (Dowling & Ehinger, 1975), its mobilization by light (Kramer, 1971) together with the findings cited earlier and corroborated or discovered in the present study are not yet sufficient to explain dopamine's intimate role in visual and non-visual functions of the retina.

Noell & Lasansky, (1959) demonstrated that electrophoretically-applied GABA is capable of suppressing both spontaneous and light-induced activity of the retina. Scholes & Roberts (1964) observed a depression of the ERG at low intensity light stimulation and an enhancement at high intensity when doses of GABA of 0.8 to 1.3 g/kg were administered IV to young chicks. Kramer et al., (1967) noted in 2 to 8 day-old chicks an initial reduction of the ERG followed by the presence of a large negative b-wave after GABA at doses of 2-4 g/kg. Under conditions of deep pentobarbital anesthesia rhythmic potentials (maintained activity) with frequencies of 5 to 9 cycles per second were evoked by GABA antagonists bicuculline or picrotoxin (Graham & Pong, 1972). They suggested that the rhythmic potentials are due to the participation of GABA in the "dyad" synapse (Dowling & Boycott, 1965). They further suggest that the bipolar cell acting presynaptically activates a ganglion cell dendrite and an amacrine cell process which synapses directly

back onto the bipolar cell terminal thus forming a reciprocal synapse. The use of GABA-blocking agents causes an "undamping" effect and the oscillatory activity becomes apparent (Graham & Pong, 1972). However, Wachtmeister & Dowling (1978) report selective depression of oscillatory potentials of the ERG of the mudpuppy by GABA.

In the present study, GABA reduced the b-wave of the ERG (cf Fig. 33) which was reversed when challenged with bicuculline. The c-wave and d-wave were also depressed (cf. Figs. 26, 27, & 32). Sometimes the effect was biphasic (compare Figures 32 and 26). In a naive preparation GABA ( $5 \times 10^{-4}M$ ) caused long-term oscillatory activity in the optic nerve (Figure 32). The period of the oscillation was about 10 minutes in the frog retina as compared with the relatively high frequency oscillation seen in the rat. This could be related to species differences (mammalian vs. amphibian); (Graham & Pong used rat retina). The long-term oscillations initiated by GABA were augmented by DA (an inhibitory transmitter) and terminated by ACh (an excitatory transmitter).

Recently, Racagni et al., (1978) reported complex interactions among GABAergic, dopaminergic and cholinergic neurons in the nigrostriatal system. The present study suggests that a similar system involving a combination of inhibitory and excitatory neurons might exist in the retina.



One very puzzling problem that must be examined in the future is the fact that the c-wave, a waveform generated in the pigment epithelium is depressed by GABA, yet does not affect the responsiveness of photoreceptors (DeVries & Friedman, 1978).

Ames & Pollen, (1969) found glycine to be inhibitory to all cell types but required high concentrations. The results were said to be indistinguishable from those of GABA. Glycine depressed P II (b-wave) of the carp retina more strongly than proximal P III and left the receptor potential (distal P III) unchanged (Murakami *et al.*, 1972). Loss of oscillatory potentials occurred 1 hour and after administration of glycine in the rabbit retina and took 20 to 24 hours to recover (Korol & Owens, 1974). Depression of oscillatory potentials with glycine was demonstrated in the mudpuppy by Wachtmeister & Dowling (1978).

One has the impression from the present study that glycine exerts an inhibitory action. However, the period of observation, less than an hour, was probably too short to see maximal effects.

Histamine depresses b-, c- and d-wave amplitude and moves the SP of the eye and optic nerve downward. Histamine is known to produce both excitatory and inhibitory effects in the CNS (cf. review J.C. Schwartz 1977). These effects are dose-dependent, for example, low doses facilitate

ganglionic transmission in superior cervical ganglion of the cat, while high doses produce a transmission block (Cooper et al., 1974).

Excitation apparently is the result of  $h_1$  receptor action and depression could be attributable to an  $h_2$  receptor function. The depression of ERG function seen in the present study reflects a high dose action of histamine. An underlying ionic mechanism for histamine's excitatory or inhibitory action is unknown. However, in Aplysia, excitation results from increase  $Na^+$  conductance. Increased  $K^+$  conductances produces a slow hyperpolarization.

Straschill (1968) reported that after intraarterial injection of 5-HT there was a depression of spontaneous and light-induced activity with a suggestion of dose-dependence in unit recordings from the mouse eye. In a subsequent study on the cat retina, they noted that iontophoretic application of 5-HT left 18 of 20 neurons unaffected and acted as a weak depressant on the 2 neurons (Straschill & Perwein 1969). Ames & Pollen (1969) reported enhancement of ganglionic activity of 5-HT in the isolated rabbit retina.

Serotonin in the present study (never administered to naive eyes) moved SPs in an upward direction, transiently augmented the c-wave and produced some depression of all other wave forms studied including the a-wave, but not in a consistent manner.

An inhibitory action of 5-HT in the CNS is supported by extensive data (Marczynski, 1976).

Acetylcholine is considered, by many investigators, a putative transmitter in the CNS. Recently, Freeman (1977) obtained evidence that ACh is an excitatory neurotransmitter at the optic tectum of the toad Bufo marinus displaying nicotinic characteristics. He indicated that ACh is used by at least two different classes of ganglion cells, Class I and Class IV. The retino-tectal synapses were found to contain high levels of ACh, ChAc and AChE. As with many of the other retinal neurotransmitter suspects, ACh content varies with the species. Graham, (1974) suggests that the cholinergic system would best be studied in the retina of the rat or squirrel because of their high ACh content. Conversely, the mudpuppy, frog, cats or dogs would be a poor choice because the ACh content of their cholinergic system is low.

Graham's conclusion is not necessarily valid with respect to the frog or other retinae. More sensitive methods have been developed, e.g. neurotoxin binding; current-source density analysis, etc. (See pages 30-31) which would permit one to discriminate smaller, intimate changes in neurotransmitter activity.

Noell & Lasansky, (1959) using rabbit and cat retinas observed increased unit activity following iontophoretic

application of ACh. Straschill (1968), studying unit discharges in the cat retina, found that ACh injected into the carotid artery usually enhanced, but sometimes depressed, spontaneous unit firing. Murakami et al., (1972) found that ACh had no effect on horizontal cells.

In the present study ACh administered to naive preparations moved the SP's of the eye and optic nerve in a downward direction; in other preparations, the SP moved in either direction. The change in the SP of the optic nerve could reflect the algebraic summation of depolarization of synapses in the stimulated eye. Note: in Fig. 22, a modest downward deflection occurred in the SP of eye and optic nerve of a photically-unstimulated but ACh-challenged preparation.

Mecholyl (methacholine chloride) is a choline ester relatively-resistant to hydrolysis and devoid of nicotinic activity. Mecholyl ( $10^{-4}$ M) caused an initial upward then downward shift of the SP of the eye. The c-wave is clearly depressed and considerable augmentation of the b- and d-waves of the ERG occur. The responses of the "b"-wave of the optic nerve increase while the "d"-wave diminish.

The Mecholyl responses after hexamethonium, a ganglionic blocking drug (nicotinic receptors) are unaffected. When Mecholyl is given after atropine, a muscarinic blocker,

the responses to Mecholyl do not occur indicating a possible blockade of the muscarinic action of Mecholyl.

Carbachol was administered three times in a naive preparation (Figure 30). The first dose,  $1.1 \times 10^{-5}M$ , caused an increase in c-wave amplitude with an upward shift of the SP of the eye. The second dose,  $2.7 \times 10^{-5}M$ , elicited similar responses. TEA, a ganglion blocking agent, ( $1 \times 10^{-10}M$ ) was given before the third dose of Carbachol ( $2.7 \times 10^{-5}M$ ). Carbachol produced a very slight c-wave response. Almost complete block of the SP response of the eye occurred while in the optic nerve, the SP shifted upward slightly.

Byzov et al., (1970) found that tetrodotoxin was capable of blocking impulse transmission in the optic nerve of the frog eyecup preparation. Signal transmission in the form of slow-potential (SP) oscillations was unaffected. The preservation of the SP of the optic nerve after TTX indicates that transmission of signals from the photoreceptors to the ganglion cells can occur even though impulses are absent.

Tetrodotoxin which blocks sodium channels to prevent the influx of sodium during the rising phase of the action potential (Narahashi, 1974) had a stabilizing effect on the standing potential of the eye moving it in a positive-going direction prior to attaining a  $dy/dt$  of 0 mV/min. Transient

currents are carried primarily by sodium ions while steady state current is the function of potassium ions. Calcium conductance comprises 2 phases - an early phase that parallels the rise in  $\text{Na}^+$  conductance which is blocked by TTX, and a late phase that is TTX insensitive and resembles the properties of the potassium (steady state) channel. Membrane current and potential changes elicited when barnacle photoreceptors are illuminated are unaffected by TTX.

Once the effects of the vast array of neurotransmitter suspects are sorted out in such a preparation as this, the isolated perfused frog eye with its complex retina, it will be possible to examine and screen new drugs with respect to actions on photoreceptors, neural retina and retinal pigment epithelium as well as on retinal blood flow.

Drugs are routinely given to patients without regard to their possible retinal toxicity. Part of the normal screening for human use does not include the assessment of retinal function on an acute or chronic basis, even though common drugs have been shown to alter responses of the retina. For example, Friedman & Marchese (1978) recently found that caffeine and thyroxine can alter the duration of positive afterimages evoked by strobe-flash. An improved understanding of retinal physiology and pharmacological reactions of the retina can be expected to lead to the solution of chronic problems such as the retinal dystrophies

especially retinitis pigmentosa and to the prevention of drug-induced problems.

Apologia pro opus mea

Armington gratias

Despite the recent extraordinary progress in retinal physiology investigators often do not know what aspect of retinal function is described by a measurement of some characteristics of the ERG. Nevertheless, the measurements may lead to important conclusions and permit a better understanding of visual function. The justification for the measuring procedures lies in their utility in relating data of one study to another, and in relating the ERG to other measures of visual function. (Armington 1974).

## A CRITIQUE OF THE ISOLATED PERFUSED EYE PREPARATION

By examining the history of the development of the techniques and preparations used in this investigation, one can appreciate the problems that were recognized, considered and solved in order to achieve a reliable experimental preparation. On the 100th anniversary of the birth of Albert Einstein it is worth quoting him with respect to the above. "I know from my own painful searching, with its many blind alleys, how hard it is to take a reliable step, be it ever so small, towards that which is truly significant."

Only large eyes from bullfrogs, Rana catesbeiana, and large leopard frogs, Rana pipiens, could be used in these experiments principally because of the difficulty in inserting the perfusion cannula into the lumen of the cut ophthalmic artery. The lumen was slightly dilated using the spreading action of a fine jeweler's forceps. The outer diameter of #10 polyethylene cannula is 0.6 mm, while the tapered outer diameter of the #50 tubing is 0.5 mm. Eagle's basal culture medium containing 10% fetal calf serum (appendix) used initially was equilibrated with 95% O<sub>2</sub> 5% CO<sub>2</sub> mixture according to Gouras & Hoff (1970). They state:

as far as we know, there is no other organized cellular structure in the mammalian central nervous system that has exhibited this kind of normal function in organ culture with a perfusate devoid of hemoglobin.



Tissue culture media such as Eagle's regularly contain amino acids such as glutamine, histidine, phenylalanine, tryptophan, etc. These substances are precursors of some of the neurotransmitters. It would seem that a physiological salt solution devoid of amino acids would be more suitable as a perfusal medium for neuropharmacological experiments. Clark's frog ringer solution was discarded because electrophysiological responses deteriorated with its use within 2 to 3 hours. Sickel's media which was successfully used with the isolated retina preparation, was tested using air as the oxygenating gas (as for the isolated retina). This preparation deteriorated prematurely. When eyes were examined at the end of the experiment it was apparent that the anterior chamber of the eye was filled with fluid and the cornea was grossly swollen and protruded forward. Samples of frog blood drawn by cardiac puncture were 225 milliosmolar. An artificial plasma expander Pluronic F68<sup>R</sup> used in organ culture perfusion was added to Sickel's medium to approximate frog blood osmolarity, resulting in normal appearing corneas. However, the potentials obtained from the preparation again deteriorated prematurely. It was determined that due to the absence of hemoglobin in media and the low O<sub>2</sub> content of air that an O<sub>2</sub>-CO<sub>2</sub> mixture should be used to increase the PO<sub>2</sub> to make up for lack of hemoglobin. The buffer system of Sickel's media could not

accommodate and the final pH was too low. The saline solution of Phillis & Tebicis (appendix) was then tested (pH equilibrated at 7.4). ERG responses obtained were devoid of c-waves and the b- and d-waves diminished rapidly. Replacing the Phillis & Tebicis saline with Sickel's salt solution gassed with 100% O<sub>2</sub> restored the b- and d-wave amplitudes. However, corneal protrusion was again noted and it was assumed to be a problem of hydrostatic pressure effects of the modified saline solution. The problem was solved when Sickel's salt solution was combined with 2% fetal calf serum and oxygenated with 100% O<sub>2</sub>. This combination resulted in preparations that could last many hours. ERGs were recorded for 20 hours after enucleation in one preparation. ERG's and optic nerve potentials of normal shape and amplitude obtained for many hours were indicative of the presence of synaptic transmission from the photoreceptors to the ganglion cell layer of the retina.

Perfusion in initial experiments was accomplished by precisely-controlled hydrostatic pressure applied to the media delivery system which approximated frog arterial pressure (25-45 mmHg). Flow rates were measured by counting the drops produced or released per minute and were found to vary from one preparation to another. This is to be expected since there are individual variations in the branches of the ophthalmic artery, in the placement of cannula, and the

degree of damage to the artery during surgery. When possible, any leaking blood vessel was cauterized or tied off by fine ligatures. Higher flow rates obtained when the #50 tapered cannula replaced the #10 PE tubing resulted in an improvement of the light-evoked responses.

The retina has an unusually high oxygen requirement; therefore, the oxygen dissolved in the physiological saline perfusing through the eye is rapidly exhausted especially because hemoglobin is absent (Niemeyer, 1975). In order to compensate for lack of hemoglobin an increased  $PO_2$  and an increased flow rate are necessary.

Use of a constant volume perfusion pump minimized the effects of vascular resistance. In some experiments the drugs used altered flow by causing closure of vascular beds. It is known that some drugs (NE, DA) have central vascular effects. NE causes vasoconstriction, DA causes vasodilatation. Fig. 26 shows a computer drawn plot of drug effects on perfusion rate in the perfused eye maintained at a constant pressure. When vasoconstriction occurs there is a reduction in rate of flow and an augmentation of flow rate following vasodilatation.

Electrodes were chosen for this preparation based on their ability to record slowly-changing events as well as rapid, pulsatile responses, simultaneously. Corneal Ag-AgCl electrodes failed because of progressive dessication at the

electrode-cornea interface. Occasional addition of saline over the cornea resulted in large artifacts. KCl-filled micropipettes with Ag-AgCl lead-off wires also were unsatisfactory because there is a photovoltaic artifact produced when they are exposed to the light stimulus. Attempts to cover the Ag-AgCl-KCl interface failed because of the "light-piping" of the glass capillary which carried a portion of the stimulus light to the electrode. Construction and use of calomel-half cell electrodes solved the problem inasmuch as they are very stable and insensitive to light. The capillary portion of the electrode containing frog saline was inserted through a hole punctured in the sclera into the vitreous humor just behind the lens.

The potentials recorded in this study originate from various structures in the retina. While much study on the origin of components has occurred with microelectrode recording, field potentials originating from the horizontal cells, bipolar cells, amacrine or ganglion cells have not been identified. This is mainly because the cells which are laterally-disposed (e.g., horizontals) have no detectable radial field component. Responses of other cell types are overshadowed by the contributions from the photoreceptors and Müller cells. Field potentials of the eye arise as a result of current originating in a group of cells flowing through the extracellular medium. Because of the radial

disposition of the photoreceptors the radial components of their extracellular currents add in a constructive or summing manner. Cells such as amacrine have no preferred orientation along the same axis as the photoreceptors so their currents tend to cancel and their contribution is absent from the overall response (Rodieck, 1973). Simultaneous recording of the gross ERG (field potential) and specialized techniques as the local current source-density method reported by Freeman & Nicholson (1975) would be extremely valuable in determining the further localization of component responses in the inner plexiform layer.

The employment of an intravitreal active electrode with indifferent electrode on posterior sclera utilized in this study results in a less-attenuated potential. The current pathways involved (Fig. XVIII-5 Rodieck, 1973) using the extraocular pathway are largely shunted resulting in relatively small potentials. Recording from the vitreous to sclera reduces the shunting occurring on the surface of the eye and results in a larger potential.

Recording from the short stump of optic nerve available proved exceedingly difficult. This is discussed earlier (p 108) in the section Recording from the Optic Nerve. To recapitulate briefly, the specially-designed sucrose gap effectively isolates the optic nerve potentials from those

emanating from the retina and limits the problem of confounding two ongoing electrophysiological processes.

ERG's elicited in the earlier experiments of this study used the brief flash of a xenon discharge tube (see Figs. 2, 7 & 13). Advantages of this stimulus source are:

- a. They provide an intense flash of very brief duration.
- b. The spectrum resembles daylight.
- c. They are controlled by electronic circuits which facilitate synchronization with other equipment.

Disadvantages are:

- a. The design of the power supply is important. Less expensive units do not produce successive equal-energy flashes; i.e., light output is not constant.
- b. Aging of the tube causes further erratic performance.
- c. The loosely-coiled design of the tube makes it difficult to efficiently introduce it into simple optical systems.
- d. Measurement of flash intensity is difficult to achieve with common photometric instruments.
- e. The electrical discharge in the tube produces transients which are seen as artifacts in the recordings.

Light from an incandescent ribbon filament focussed on the slit of a monochromator was used for the majority of the isolated perfused eye experiments. Lurie (1973) suggested that a diffuse, homogenous stimulus which encompassed the entire retina provided greater stability of response. If parts of the retina were unstimulated they interact to produce an unstable oscillating base line of the SP.

The overall output of the monochromator was relatively low. At 405, 540 & 640 nm the output was 19-95 and 145  $\mu\text{W}/\text{cm}^2$ , respectively.

(The maximal energy of the photostimulator used by Niemeyer (1975) was 1.1 milliwatt at 520 nm). Monochromatic light at 540 nm was chosen as the stimulus wavelength to take advantage of the maximal sensitivity of the eye relative to the low stimulus intensity available.

Stimulus duration was 10 seconds. At the stimulus intensity level used this provided for a fully-developed c-wave (Figs. 16, 17) which combined with a 100 second interval between stimuli permitted the complete return to a "dark-adapted" baseline.

## SUMMARY

1. Experiments were performed on isolated eyes of large, partially dark-adapted frogs (Rana pipiens & Rana catesbeiana) perfused through the ophthalmic artery with oxygenated Sickel's media under pressure.
2. Non-polarizable calomel half-cell electrodes were placed on the sclera and into the vitreous humor to record the ERG. Ag-AgCl electrodes wrapped around the optic nerve were used to record optic nerve potentials. A specially designed sucrose gap isolated the optic nerve potentials from that of the globe of the eye.
3. Perfusion was accomplished by two methods: (a) constant pressure at levels simulating frog arterial pressure, and (b) constant volume, using a perfusion pump to overcome drug and physiologically-induced vascular resistance.
4. ERGs and optic nerve potentials were elicited using incandescent light in combination with a grating monochromator or occasionally by xenon flash. Responses to light of various wavelengths and duration were assessed.
5. Routinely, the preparations were stimulated for 10 seconds every 100 seconds for as long as 9 hours.
6. Drugs dissolved in Sickel's media were administered either as a bolus or by continuous delivery from a reservoir containing the drug.



7. The inter-drug interval was usually 10 minutes for single injections or longer depending on the flow rate for a selected volume of solution.
8. During the course of a screening experiment, drugs representing several types were perfused, usually at a single concentration. In other experiments, several concentrations were assessed. Agonist-antagonist pairs comprised another type of experiment.
9. The drugs were selected primarily because they were expected to interact with or modify normal constituents of the retina.
10. Parameters measured during the usual experiment included (a) perfusion rates, (b) temperature, (c) the SP of the eye, (d) the c-wave, (e) the b-wave, (f) the d-wave, (g) the a-wave (less frequently), (h) the SP of the optic nerve, (i) the "b"-wave of the optic nerve, (j) the "d"-wave of the optic nerve and, occasionally, (k) the "c"-wave of the optic nerve.
11. Recording modes were both a.c. and d.c. in order to measure short and long-term ERG and ONP components.
12. Evoked responses picked up by the electrodes were led off by suitable d.c. and a.c. pre-and-post amplifiers to a distribution panel connected to an 8-channel FM tape-recording system, a 4-channel ink-writing polygraph and dual-beam storage oscilloscopes.

13. In one special application the potentials were triggered by a multifunction-stimulator connected via a relay to a time-lapse recording camera and a dual-beam oscilloscope.
14. Potentials were measured by eye, transferred to compiler sheets, punch cards and floppy discs for analyses by an IBM370 system which generated computer plots to facilitate reviewing of a lengthy experiment.
15. The sensitivity of the frog eye obtained in plotting b-wave amplitude vs. wavelength for 405 and 640 nm is at variance with that of Granit & Munsterhjelm, (1937) by a factor >2. Sensitivity determined at 405 nm in the present study is  $74 \pm 18.8\%$  vs. 30%; at 640 nm it is  $62.4 \pm 4.7\%$  vs. 20% relative to a 502 nm reference wavelength set at 100%.
16. The standing potential of the eye and optic nerve of the photically unstimulated eye responds to drugs (Figure 22). Positive-going deflections occur after dopamine,  $K^+$ , NE and Na azide while negative-going deflections occur after  $Ca^{++}$ , ACh, Carbachol and taurine in the SP (eye). In the SP of the optic nerve negative-going deflections are seen after  $K^+$ , NE and DA. Positive deflections in optic nerve SP result from  $Ca^{++}$ , histamine, ACh, Carbachol and 5-HT administration. The onset of action of drug-induced potentials seen in the optic

nerve are delayed relative to that of the eye. Ordinarily photic stimulated activity in the optic nerve precedes that in the globe.

17. In the photically-stimulated preparation various type drugs including agonist-antagonist pairs were perfused and their effect on ERG components (b-, c-, d-, and infrequently, a-waves) were evaluated. The SP of the eye and optic nerve as well as ONP components ("b"- and "d"-waves) were also measured. Drug effects described are generalizations based on the usually-observed effect.
18. Norepinephrine moved the SP of the eye in a positive-going direction in a dose-dependent fashion (Table III), while the SP of the optic nerve initially positive-going stabilized and proceeded in a negative-going direction with increasing doses. The rate of change of the optic nerve SP varied with respect to dose. NE increased b-wave and "b"-wave amplitudes; the former however, decreased at higher doses. The c-wave amplitude increased moderately at all doses. The d-wave in the dose-response study was depressed by NE, while the "d"-wave was enhanced. Phenoxybenzamine ( $10^{-3}$ M) did not alter the ERG or SP of the eye but unmasked long-term oscillatory activity in the "b" and "d" responses of the optic nerve as well as increasing the rate at which the optic nerve SP became more negative (Fig. 23).

19. Epinephrine (not studied in naive preparations) moved the SP of the eye and optic nerve in a negative-going direction. B-, d-, a-, and "b"-wave amplitude increased with single doses while "d"-wave amplitude decreased.
20. Dopamine increases the positivity of the SP (eye) in a dose-related fashion and decreases the b-, c- and d-wave amplitudes. Haloperidol, a dopamine antagonist without apparent effect on the SP (eye), restores the amplitudes of the aforementioned ERG components (Figure 28). The SP (optic nerve) moves in a positive-going direction at low dose and in a negative-going direction at higher doses. A long-period oscillation of the "b" and "d"-waves (swinging alternately and significantly from increase to decrease, cf. Figure 32) initiated by GABA is enhanced by dopamine and stabilized by ACh.
21. Blood flow increases after dopamine (Figure 26) reflecting its ability to dilate retinal blood vessels.
22. GABA reduced b-wave amplitude (Figure 33) which is reversible by bicuculline, a GABA antagonist. The SP (eye) becomes more positive in 4/7 preparations. After GABA, c- as well as b- and d-wave amplitudes diminish. The SP (optic nerve) becomes more negative at  $1.9 \times 10^{-4} \text{M}$  and moves in a positive-going direction at  $10^{-3} \text{M}$  (cf. Figure 26). Picrotoxin, another GABA antagonist, in

non-naive preparations moved the SP of the eye and optic nerve in a positive-going direction .

23. Oscillatory activity of optic nerve "b" and "d"-waves with a period of 10 minutes and greater is a marked effect of GABA in a naive preparation (vide supra, Summary item No. 20).
24. Perfusion rates after GABA administration are reduced (cf. Figure 26).
25. Picrotoxin, a GABA antagonist, (vide supra, No. 22), moved both SP's in a positive-going direction. B-, d- and c-waves are augmented. In the case of the latter, there was a secondary reduction in amplitude.
26. Glycine, administered late in experiments and not to naive preparations tends to depress ERG and optic nerve potentials. SP's move in a positive-going direction although not consistently. Flow rate increases after glycine.
27. Strychnine, a glycine and taurine antagonist, moved the SP (eye) in a negative-going direction (Figure 24) but not consistently. The c-, b- and d-waves decreased in some preparations, augmented slightly in others. The SP (optic nerve) moved slightly in the direction of the negative.
28. Histamine, which augments flow rate (Figure 26) was not administered to naive preparations. It moved the SP of

the eye in a negative-going and that of the optic nerve in a positive-going direction (cf. Figure 22). Depression of c-, b- and d-wave amplitude occurs. The a-wave, measured in a single preparation, was depressed but transiently increased in amplitude.

29. Serotonin augments flow rate (Figure 26) and was administered just after NE. The trend for the SP of the eye was in a positive-moving direction while that of the optic nerve was in a negative-moving direction. The c-wave amplitude transiently increased and subsequently diminished in size.
30. Acetylcholine increases flow rate and increases the negativity of the SP of the eye and the positivity of the SP of the optic nerve in naive preparations. Amplitudes of the b- and "b"-waves augment while those of the c-wave generally decrease.
31. Mecholyl in naive preparations moves the SP of the eye and optic nerve in a negative direction, although that of the former initially becomes positive. The c-wave and "d"-wave decrease while the b-wave and d-wave increase.
32. Carbachol after a transient positive phase moves the SP of the eye in a negative direction and the SP of the optic nerve in a positive direction (like ACh). All ERG and ONP components (with the exception of the b-wave

which increases) are reduced in amplitude after carbachol. However in a naive preparation - (cf. Figure 30) - Carbachol markedly increases the c-wave.

33. Edrophonium, an anticholinesterase, produces a biphasic effect on the SP of the optic nerve and the eye which is especially striking in the case of the former (Figure 30). Biphasic effects also occur with the c-wave. Neostigmine, another anticholinesterase, administered at the conclusion of an experiment augmented the c-wave.
34. Tremorine administered to a non-naive preparation produced a biphasic effect on the SP (eye) at two dose levels used, while SP (optic nerve) moved slightly positive with the first dose and negative with the second. Tremorine's effect on the c-wave was biphasic (Figure 30). Oxotremorine effects were unremarkable.
35. Nicotine, given to non-naive preparations gave equivocal results with respect to SP's. However, b-, d- and "d"-waves generally increase in amplitude.
36. Ganglioplegics, TEA and C-6 move SP (eye) in a negative-going direction and SP (optic nerve) in a positive-going direction. The c- and b-waves are decreased by both; the "d"- and "b"-waves are decreased by C-6. Washout of C-6 is attended by a rebound increase of b- and c-waves.

37. Tetrodotoxin stabilized the SP of the eye. The c-wave is unaffected; b- and d-waves are depressed, while only slight changes occur with the "b"- and "d"- waves.



## CONCLUSIONS

1. The potentials recorded from an isolated perfused frog eye do not differ basically from those recorded in an intact animal.
2. A region of the spectrum not used for human vision, the near UV (365 nm), produces unexpectedly-high responses in:
  - a. the isolated perfused frog eye
  - b. the eyes of curarized frogssuggesting the possibility of another channel for transmitting information to the CNS.
3. The SPs of the photically unstimulated isolated perfused eye and its optic nerve are affected by neuroactive drugs and ions.
4. Neurotransmitters like those located in the neural retina when perfused through the eye modify the potentials of the retina and optic nerve evoked by light.
5. Neurotransmitter antagonists tend to reverse the light-evoked effects of exogenous and unmask the effects of endogenous putative neurotransmitters upon the retina and optic nerve.
6. The drug effects obtained on the retina and optic nerve appear to be independent of their effects on retinal circulation.

7. In view of these findings, the isolated perfused eye appears to be a useful tool for examining physiological and pharmacological activity and for ascertaining mechanisms that underlie retinal function.

## REFERENCES

- Adrian, E. D. (1945) The electric response of the human eye. J. Physiol. 104: 84-104
- Adrian, E. D. (1946) Rod and cone components in the electric response of the eye. J. Physiol. 105: 24-37
- Adrian, E. D. & Matthews, Rachel (1927) The action of light on the eye. Part I. The discharge of impulses in the optic nerve and its relation to the electric changes in the retina. J. Physiol. 63: 378-414
- Alfieri, R. and Solé, P., (1969) On very short wavelength electroretinography. 3rd Congr. Europ. Soc. Ophthal., Amsterdam 1968 Ophthalmologica Additamentum ad vol 158: 661-668.
- Alm, A. (1972) Aspects of pharmacological regulation of blood flow through retina and uvea. A study in cats and monkeys. Acta. Univ. Upsalien. 137: 1-28
- Alm, A., & Bill, A. (1972) The oxygen supply to the retina, II. effects of high intraocular pressure and of increased arterial carbon dioxide tension on uveal and retinal blood flow in cats. Acta. Physiol. Scand. 88: 84-94
- Alm, A. and Bill, A. (1973) Ocular and optic nerve blood flow at normal and increased intraocular pressures in monkeys (Maccaca irus): a study with radioactively labeled microspheres including flow determinations in brain and some other tissues. Exptl. Eye Res. 15: 15-20
- Ames, III, A. & Gurian, B. S. (1963) Effects of glucose and oxygen deprivation on function of isolated mammalian retina. J. Neurophysiol. 26: 617-634
- Ames, III, A., Isukada, Y. & Nesbett, F. B. (1967) Intracellular Cl, Na, K, Ca, Mg and P in nervous tissue; response to glutamate and to changes in extracellular calcium. J. Neurochem. 14: 145-159
- Ames, III, A., & Pollen, D. A. (1969) Neurotransmission in central nervous tissue; a study of isolated rabbit retina. J. Neurophysiol. 32: 424-442

- Armington, J. C. (1952) A component of human electroretinogram associated with red vision. J. Ophth. Soc. Amer. 43: 350-456
- Armington, J. C. (1974) The Electroretinogram. Academic Press, N. Y.
- Autrum, H. (1951) Erregungsvorgange und Leistungen Des Insectenauges. Verh: Dtsh. Zool. Gesellsch. Wilhelmshaven, 133-143
- Baker, P. C. (1966) Development of 5 hydroxytryptophan decarboxylase in the brain, eye and whole embryo of Xenopus laevis. Neuroendocrinology. 1: 257-264
- Baker, P. C. & Quay, W. B. (1969) 5-Hydroxytryptamine metabolism in early embryogenesis, and the development of brain and retinal tissues. A review. Brain Res. 12: 273-295
- Baker, P. C., Hoff, K. M. & Clise, R. L. (1971). The effects of light and dark backgrounds upon indoleamine enzymes in developing Xenopus laevis. Comp. gen. Pharmac. 2: 397-401
- Barlow, H. B., Hill, R. M., & Levick, W. R. (1964) Retinal ganglion cells responding selectively to direction and speed at image motion in the rabbit. J. Physiol. 173: 377-407
- Bartley, S. H. & Bishop, G. H. (1942) Some features of the optic nerve discharge in the rabbit and cat. J. Cell. & Comp. Physiol. 19: 79-93
- Baumann, C. H. (1965) Die photosensitirtat des sehpurpurs in der isolierten netzhaut. Vision Res. 5: 425-434
- Baylor, D. A., Fuortes, M. G. F., & O'Bryan, P. M. (1971) Receptive fields of cones in the retina of the turtle. J. Physiol. 214: 265-294
- Bill, A. (1975) Blood circulation and fluid dynamics in the eye. Physiol. Rev. 55: 383-417
- Boll, F. (1876) Zur Anatomie and Physiologie der Retina. Monatsber. Pruess. Akad. Wiss. Berlin. 787-812

- Bonaventure, N., Wioland, N. & Mandel, P. (1974) Antagonists of the putative inhibitory transmitter effects of taurine and GABA in the retina. Brain Res. 80: 281-289
- Bonting, S. L. (1976) Transmitters in the Visual Process. Pergamon Press, Ltd. Oxford, New York
- Bonting, S. L. & Daemen, F. J. M. (1976) Calcium as a transmitter in photoreceptor cells. Transmitters in the Visual Process. Ed. S. L. Bonting. pp. 59-88 Pergamon Press, Ltd. Oxford, New York
- Boycott, B. B. & Dowling, J. E. (1969). Organization of the primate retina: Light microscope. Phil. Trans. Roy. Soc. B 255: 109-184.
- Boynton, R. M. & Triedman, M. H. (1953) A psychophysical and electrophysiological study of light adaptation. J. Exptl. Psych. 46: 125-234
- Brindley, G. S. (1956a) The passive, electrical properties of the frog's retina, choroidal sclera for radial fields and currents. J. Physiol. 134: 339-352
- Brindley, G. S. (1956b) The effect on the frog's electroretinogram of varying the amount of the retina illuminated. J. Physiol. 134: 353-359
- Brindley, G. S. (1956c) Responses to illuminated recorded by microelectrodes from the frog's retina. J. Physiol. 134: 360-384
- Brindley, G. S. (1956d) The resting potential of the lens. Brit. J. Ophthal. 40: 385-391
- Brindley, G. S. (1958) The sources of slow electrical activity in the frog's retina. J. Physiol. 140: 247-261
- Brindley, G. S. (1970) The Physiology of the Retina and Visual Pathway. Williams & Wilkins Co., Baltimore
- Brooks, B. & Muirhead, E. (1972) Routine aortic pressure measurement of the conscious rabbit. Archives of Path. 93: 464-466

- Brown, K. T. (1968) The electroretinogram - its components and their origins. Vision Res. 8: 633-677
- Brown, K. T. & Weisel, T. N. (1961a) Analysis of the intraretinal electroretinogram in the intact cat eye. J. Physiol. 158: 229-256
- Brown, K. T. & Weisel, T. N. (1961b) Localization of origins of electroretinogram components by intraretinal recording in the intact cat eye. J. Physiol. 158: 257-280
- Brown, K. T. & Murakami, M. (1964) A new receptor potential of the monkey retina with no detectable latency. Nature. 201: 626-628
- Brown, K. T., Watanabe, K. & Murakami, M. (1965) The early and late receptor potentials of monkey cones and rods. Cold Spring Harbor Symp. Quant. Biol. 30: 457-482
- von Brücke, E. & Garten, S. (1907) Zur vergleichenden Physiologie der Netzhautströme. Pflüg. Arch. Ges. Physiol. 120: 290-348
- Bruun, A. & Ehinger, B. (1972) Uptake of the putative neurotransmitter, glycine, into the rabbit retina. Invest. Ophthalm. 11: 191-198
- Bubenik, G. A., Purtill, R. A., Brown, G. M., & Grota, L. J. (1978) Melatonin in the retina and the Harderian gland. Ontogeny, diurnal variations and melatonin treatment. Exp. Eye Res. 27: 323-333
- Bulpitt, C. J. & Dollery, C. T. (1971) Estimation of retinal blood flow by measurement of the mean circulation time. Cardiovasc. Res. 5: 406-412
- Burés, J., Petran, M. & Zacher, J. (1960) Electrophysiological Methods in Biological Research. Academic Press, Prague
- Byzov, A. L. (1959) "The source of impulses recorded from the inner layer of the frog retina". Biofizika. 4: 414-422
- Byzov, A. L., Polischuk, N.A., & Zenkin, G.M. (1970) On the transmission of signals in vertebrate retina in the presence and absence of impulses. Neirofiziologiya. 2: 536-543 (Translation)

- Cajal, S. R. (1973) The Vertebrate Retina. Translated by Deborah Maguire and R. W. Rodieck, appearing as an appendix in The Vertebrate Retina Principles of Structure and Function by R. W. Rodieck. W. H. Freeman & Co. San Francisco
- Cardinali, D. P. & Rosner, J. M. (1971) Retinal localization of the hydroxyindole-o-methyl transferase (HIOMT) in the rat. Endocrinology. 89: 301-307
- Cardinali, D. P., Larin, F., & Wurtman, R. J. (1972) Action spectra for effects of light on hydroxyindole-o-methyltransferases in rat pineal, retina and harderian gland. Endocrinology. 91: 877-886
- Carlson, A., Rosengren, E., Bertler, A. & Nilsson, J. (1957) Effect of reserpine on the metabolism of catecholamines. In: Psychotropic Drugs. Ed. S. Garattini & V. Ghetti. Amsterdam, Elsevier Pub. Co. 363-372
- Cervetto, L. and MacNichol, E. F. (1972) Inactivation of horizontal cells in turtle retina by glutamate and aspartate. Science. 178: 767-768
- Chaffee, E., Bovie, W. & Hampson, A. (1923) The electrical response of the retina under stimulation by light. J. Opt. Soc. Amer. 7: 1-44
- Chan, R. V. & Naka, K. I. (1976) The amacrine cell. Vision Res. 16: 1119-1129
- Chandra, S. R. & Friedman, E. (1972) Choroidal blood flow. II. the effects of autonomic agents. Arch. Ophthalmol. 87: 67-69
- Chang, H. C., Lee, L. Y. & Li, T. H. (1941) Studies on tissue acetylcholine IX. Diminution of acetylcholine in the retina during functional disease. Chin. J. Physiol. 16: 373-378
- Clelland, B. G., Dubin, M. W. & Levick, N. R. (1971) Sustained and transient neurons in the cats retina and lateral geniculate nucleus. J. Physiol. 217: 473-496
- Cohen, A. I. (1972) Rods and Cones. In: Handbook of Sensory Physiology VII/2. Ed. M. G. F. Fuortes. Springer-Verlag, Berlin

- Cohen, M. W. (1970) The contribution by glial cells to surface recordings from the optic nerve of an amphibian. J. Physiol. 210: 565-580
- Cohen, A. I., McDaniel, M. & Orr, H. (1973) Absolute levels of some free amino acids in normal and biologically fractionated retinas. Invest. Ophthalmol. 12: 686-693
- Cone, R. A. (1964) Early receptor potential of the vertebrate retina. Nature 204: 736-739
- Cooper, J. R., Bloom, F. E., Roth, R. H. (1974) The Biochemical Basis of Neuropharmacology 247-251
- Crapper, D. R. & Noell, W. K. (1963) Retinal excitation and inhibition from direct electrical stimulation. J. Neurophysiol. 26: 924-947
- Crescitelli, F. & Sickel, W. (1968) Delayed off-responses recorded from the isolated frog retina. Vision Res. 8: 801-816
- Curtis, D. R. & Watkins, J. (1960) The excitation and depression of spinal neurons by structurally related amino acids. J. Neurochem. 6: 117
- Curtis, D. R. & Johnston, G. A. R. (1974) Amino acid transmitters in mammalian central nervous system. Ergebn. Physiol. Reviews of Physiol. 69: 97-188
- Dartnall, H. J. A. (1953) Interpretation of spectral sensitivity curves. Brit. Med. Bull. 9: 24-30
- Davis, J. M. Himwich, W. & Agrawal, H. (1969) Some amino acids in the developing visual system. Devel. Psychobiol. 2: 34-39
- Day, E. C. (1915) Photoelectric currents in the eye of the fish. Amer. J. Physiol. 38: 369-398
- DeRobertis, E. & Franchi, C. M. (1956) Electron microscope observations on synaptic vesicles in synapses of the retinal rods and cones. J. Biophysic. & Biochem. Cytol. 2: 307-318
- DeVries, G. W. & Friedman, A. H. (1978) GABA, picrotoxin and retinal sensitivity. Brain Res. 148: 530-535



- Dewar, J. (1876) The physiological action of light. Proc. Roy. Inst. Gr. Brit. 8/2: 137-149
- Dewar, J. (1877) The physiological action of light. I. Nature. XV: 433-435
- Dewar, J. & McKendrick, J. G. (1873a) On the physiological action of light. Trans. Roy. Soc. Edinburgh. 8: 110-114
- Dewar, J. & McKendrick, J. G. (1873b) On the physiological action of light. Trans. Roy. Soc. Edinburgh. 8: 179-182
- Dewar, J. & McKendrick, J. G. (1876) On the physiological action of light. Trans. Roy. Soc. Edinburgh. 27: 141-168
- Doty, R. W. & Kimura, D. S. (1963) Oscillatory potentials in the visual system of cats and monkeys. J. Physiol. 168: 205-218
- Dowling, J. E. (1968) Synaptic organization of the frog retina: An electron microscopic analysis comparing the retinas of frogs and primates. Proc. Roy. Soc. B 170: 205-228
- Dowling, J. E. (1970) Organization of vertebrate retinas. Invest. Ophthalm. 9: 665-680
- Dowling, J. E., Brown, J. E., & Major, Diane (1966) Synapses of horizontal cells in rabbit and cat retinas. Science 153: 1639-164
- Dowling, J. E. & Boycott, B. B. (1965) Neural connections of the retina: fine structure of the inner plexiform layer. Cold Spring Harbor Symposium Quant. Biol. 30: 393-402
- Dowling, J. E. & Werblin, F. S. (1969) Organization of retina of the mudpuppy, Necturus maculosus. I. Synaptic structure. J. Neurophysiol. 32: 315-338
- Dowling, J. E. & Ehinger, B. (1975) Synaptic organization of the amine-containing interplexiform cells of the goldfish and Cebus monkey retinas. Science 188: 270-273

- Dowling, J. E., Ehinger, B. & Hedden, W. (1976) The interplexiform cell: a new type of retinal neuron. Invest. Ophthalm. 15: 916-926
- Dowling, J. E. & Ehinger, B. (1978) The interplexiform cell system. I. Synapses of the dopaminergic neurons of the goldfish retina. Proc. R. Soc. Lond. B 201: 7-26
- Drujan, B. D., Diaz-Burges, J. & Alvarez, N. (1965) Relationship between the contents of adrenaline, noradrenaline and dopamine in the retina and its adaptational state. Life Sciences 4: 473-477
- Dubin, N. W. (1970) The inner-plexiform layer of the vertebrate retina: A quantitative and comparative electron microscopic analysis. J. Comp. Neurol. 140: 479-505
- DuBois-Reymond, E. (1849) Untersuchungen über thierische Elektrizität Berlin 2: 256-257
- Duke-Elder, S. (1958) System of Ophthalmology. Vol. 1. The Eye in Evolution. London: Kimpton
- Dzendolet, E. (1960) Standing potentials of the frog's eye. J. Opt. Soc. Amer. 50: 551-555
- Eagle, H. (1959) Amino acid metabolism in mammalian cell cultures. Science 130: 432-437
- Easton, D. M. (1945) Acetylcholine in the light and dark adapted frog retina. Proc. Soc. Expl. Biol. Med. 59: 31-33
- Ehinger, B. (1970) Autoradiographic identification of rabbit retinal neurons that take up GABA. Experientia. 26: 1063
- Ehinger, B. (1972) Uptake of tritiated glycine into neurons of the human retina. Experientia. 28: 1042
- Ehinger, B. (1976) Biogenic monoamines as transmitters in the retina. In: Transmitters in the Visual Process. Ed. S. L. Bonting, Pergamon Press, Oxford
- Ehinger, B. & Falck, B. (1969) Adrenergic retinal neurons of some new world monkeys. Z. Zellforsch. Anat. Mikrosk. 100: 364-375

- Ehinger, B. & Falck, B. (1971) Autoradiography of some suspected neurotransmitter substances: GABA, glycine, glutamine acid, histamine, dopamine and L-dopa. Brain Res. 33: 157-172
- Ehinger, B. & Floren, I. (1976) Indoleamine-accumulating neurons in the retina of rabbit, cat and goldfish. Cell Tiss. Res. 175: 37-48
- Einthoven, W. & Jolly, W. (1908) The focus and magnitude of the electrical response of the eye to stimulation by light at various intensities. Quart. J. Exp. Physiol. I: 373-416
- Elenius, V. & Lehtonen, J. (1962) Spectral sensitivity of the standing potential of the human eye. Acta. Ophth. 40: 559-566
- Enroth-Cugell, C. & Robson, J. G. (1966) The contrast sensitivity of retinal ganglion cells of the cat. J. Physiol., London 187: 517-552
- Freeman, J. A. (1977) Possible regulatory function of acetylcholine receptor in maintenance of retino-tectal synapses. Nature 269: 218-222
- Freeman, J. A. & Nicholson, C. (1975) Experimental optimization of current source-density technique for anuram cerebellum. J. Neurophysiol. 38: 369-382
- Friedman, A. H. & Marchese, A. L. (1978) Positive after-image, PAI: Early erasure by saccadic eye movement or Jendrassik Maneuver. Experientia 34: 71-72
- Gaddum, J. H. (1953) Pharmacology. 4th Ed. p. 15, Oxford Medical Publications
- Gallego, A. (1971) Celulas interplexiformes en la retina del gato. Arch. Soc. Esp. Oftal. 31: 299-304
- Gasser, H. S. (1933) Axon potentials in nerve. Cold Spring Harbor Symp. Biol. I: 138-145
- Gasser, H. S. & Erlanger, J. (1927) The role played by the sizes of constituent fibers of a nerve tract in determining the form of its action potential wave. Am. J. Physiol. 80: 522-547

- Gibbs, E. L., Gibbs, T. J. & Van Dyck, P. C. (1966) Rana pipiens: Health & disease. Laboratory Animal Care 16: 142-160
- Glow, P. H. & Rose, S. (1966) Activity of cholinesterase in the retina with different levels of physiological stimulation. Aust. J. Exp. Biol. Med. Sci. 44: 65-72
- Goldstein, E. B. (1967) Early receptor potential of the isolated (Rana pipiens) retina. Vision Res. 7: 837-845
- Gotch, F. (1903) The time relations of the photoelectric changes in the eyeball of the frog. J. Physiol. 29: 388-410
- Gouras, P. (1965) Primate retina: duplex function of dark-adapted ganglion cells. Science 147: 1593-1594
- Gouras, P. (1966) Rod and cone independence in the ERG of the dark-adapted monkey's perifovea. J. Physiol. 187: 455-464
- Gouras, P. (1967) Visual adaptation: its mechanism. Science 1: 583-584
- Gouras, P. (1976) Symposium on retinal circuitry. Preface. Invest. Ophthalm. 15: 877-880
- Gouras, P. & Hoff, M. (1970) Retinal function in an isolated, perfused mammalian eye. Invest. Ophthalm. 9: 388-399
- Graham, Jr., L. T. (1972) Intraretinal distribution of GABA content and GAD activity. Brain Res. 36: 476-479
- Graham, Jr., L. T. (1974) Comparative aspects of neurotransmitters in the retina. In: The Eye. Eds. H. Davson & L. T. Graham, Jr. Vol. 6. Acad. Press, New York
- Graham, Jr., L. T. Baxter, C. F. and Lolley, R. N. (1970) In vivo influence of light or darkness on the GABA system in the retina of the frog (Rana pipiens). Brain Res. 20: 379-388

- Graham, Jr., L. T. & Pong, S. F. (1972) Rhythmic potentials originating in rat retina. Exp. Neurol. 36: 399-403
- Granit, R. (1933) The components of the retinal action potential in mammals and their relation to the discharge in the optic nerve. J. Physiol. Lond. 77: 207-239
- Granit, R. (1935) Two types of retina and their electrical responses to intermittent stimuli in light and dark adaptation. J. Physiol. 85: 421-438
- Granit, R. (1947) Sensory Mechanisms of the Retina. Oxford University Press, London
- Granit, R. (1955) Centrifugal and antidromic effects on ganglion cells of retina. J. Neurophysiol. 18: 388-411
- Granit, R. (1959) Neural activity in the retina. In Handbook of physiology, Vol. 1, Neurophysiology, ed. Field, J., pp. 693-712. Washington: American Physiological Society
- Granit, R. (1963) Sensory Mechanisms of the Retina (Reprinted) Oxford University Press, London
- Granit, R. & Munsterhjelm, A. (1937) The electrical response of dark-adapted frog's eyes to monochromatic stimuli. J. Physiol. 88: 436-458
- Grossman, R. G. & Hampton, T. (1968) Depolarization of cortical glial cells during electrocortical activity. Brain Res. 11: 316-324
- Gruberg, E. R. & Freeman, J. A. (1975) AChE activity and ACh synthesis in the optic tectum of the toad Bufo marinus: Probable identification of an optic nerve neurotransmitter. MIT Prog. Rep. 116: 266-273
- Gurian, B. S. & Riggs, L. A. (1960) Electrical potentials within the intact frog retina. Exptl. Neurol. 2: 191-198
- Gutierrez, O. & Spiguel, R. (1971) Electroretinographic study of the effect of reserpine on the cat retina. Vis. Res. Suppl. 3: 161-170

- Gutierrez, O. & Spiguel, R. (1973) Oscillatory potentials of the cat retina: effects of adrenergic drugs. Life Sciences 13: 991-999
- Häggendal, J. & Malmfors, T. (1963) Evidence of dopamine-containing neurons in the retina of rabbits. Acta Physiol. Scan. 59: 295-296
- Häggendal, J. & Malmfors, T. (1965) Identification and cellular localization of catecholamines in the retina and the choroid of the rabbit. Acta Physiol. Scand. 64: 58-66
- Hagins, W. A. (1972) The visual process: excitatory mechanisms in the primary receptor cells. Ann. Rev. Biophys. Bioeng. 1: 131-158
- Hagins, W. A. & Yoshikami, S. (1974) A role for  $Ca^{++}$  in excitation of retinal rods and cones. Exp. Eye Res. 18: 299-305
- Hanin, I., Massarelli, R., Costa, E. (1970) Acetylcholine concentrations in rat brain: diurnal oscillation. Science 170: 341-342
- Hartline, H. K. (1938) The response of single optic nerve fibers of the vertebrate eye to illumination of the retina. Amer. J. Physiol. 121: 400-415
- Hayes, K. C., Carey, R. E. & Schmidt, S. Y. (1975) Retinal degeneration associated with taurine deficiency in the cat. Science 188: 949-951
- Hebb, C. O. (1955) Cholineacetylase in mammalian and avian sensory systems. Q. J. Exp. Physiol. 40: 176-186
- Hedden, W. L. & Dowling, J. E. (1975) Dopamine effects on horizontal cells in the goldfish retina. Presented at the Association for Research in Vision and Ophthalmology meeting, Sarasota, Florida, Apr. 28 - May 2, 1975
- Hedden, Jr., W. L. & Dowling, J. E. (1978) The interplexiform cell system. II. effects of dopamine on goldfish retinal neurons. Proc. Roy. Soc. Lond. B. 201: 27-55
- Henkes, H. E. & Deutman, A. E. (1973) Electrodiagnostic procedures in drug-induced ocular disease. Doc. Ophth. 34: 209-219

- Himstedt, F. & Nagel, W. (1902) Versuche über die Reizwirkung verschiedener Strahlenarten auf Menschen und Thieraugen. Festschrift. der Universität in Frieberg XI: 259-274
- Hoff, K. M., Baker, P. C. & Clise, R. L. (1972) No effect of LSD upon 5-hydroxytryptamine level in mouse eye. Comp. Gen. Pharmac. 3: 98-100
- Holmgren, F. (1865) Method att objectivera effecten af ljusinttryck på retina. Upsala Laharef. förk. 1: 177-191 (cited in Granit, 1947)
- Holmgren, F. (1879-1880) Über die Retinaströme. Untersuchung Physiologisches, Institut der Universität at Heidelberg 3: 278-326
- Honda, Y. (1972) Quantitative analysis of some effects of ouabain upon the electrical activity of mammalian retinas. Invest. Ophthalm. 11: 699-705
- Hubbard, Ruth (1958) Bleaching of rhodopsin by light and by heat. Nature 181: 1126
- Imaizumi, K., Tazawa, Y., Ogawa, K., Mera, H. & Otsuka, T. (1972) Electrophysiological application of the living extracorporeal bovine eye. The visual system: Neurophysiology. Biophysics and their clinical applications. 24: Proceedings of the 9th ISCERG Symposium 119, Plenum Press, New York, London
- Imaizumi, K., Tazawa, Y., Otsuka, T. & Imaizumi, H. (1974) Electroretinogram of the living extracorporeal bovine eye and blood flow. Jap. J. Ophthalm. 18: 177-186
- Janz, G. J. & Ives, D. J. G. (1968) Silver, silver chloride electrodes. Annals N.Y. Acad. Sci. 148: 210-221
- Kado, R. T. & Adey, W. R. (1968) Electrode problems in central nervous monitoring in performing subjects. Annals N. Y. Acad. Sci. 148: 263-278
- Kalinina, A. V. (1976) Quantity and topography of frog's retinal ganglion cells. Vision Res. 16: 929-934
- Kaneko, A. (1970) Physiological and morphological identification and horizontal, bipolar and amacrine cells in goldfish retina. J. Physiol. Lond. 207: 623-633

- Kaneko, A. & Hashimoto, H. (1969) Electrophysiological study of single neurons in the inner nuclear layer of the carp retina. Vision Res. 9: 37-55
- Kaneko, A., Shimazaki, H. (1975) Synaptic transmission from photoreceptors to bipolar and horizontal cells in the carp retina. Cold Springs Harbor Symp. on Quant. Biol. XL: 537-546
- Karahashi, Y. & Goldring, S. (1966) Intracellular potentials from idle cells in cerebral cortex of cat. Electroenceph. Clin. Neurophysiol. 20: 600-607
- Karwaski, C. J. & Proenza, L. M. (1977) Relationship between Müller cell responses, a local transretinal potential and potassium flux. J. Neurophysiol. 40: 244-259
- Kikawada, N. (1968) Variations in the corneo-retinal standing potential of the vertebrate eye during light- and dark-adaptations. Jap. J. Physiol. 18: 687-702
- Kishida, K. & Naka, K. (1967) Amino acids and the spikes from the retinal ganglion cells. Science 156: 648-650
- Kishida, K. & Naka, K. (1968) Interaction of excitatory and depressant amino acids in the frog retina. J. Neurochem. 15: 833-841
- Knave, B. (1970) Long-term effects of high intensity flashes on the ERG of the rabbit. Acta Physiol. Scand. 78: 478-490
- Knave, B. & Persson, H. E. (1974a) The effect of barbiturate on retinal functions. I. effect on the conventional ERG of the sheep eye. Acta Physiol. Scand. 91: 53-60
- Knave, B., Persson, H. E. & Nilsson, S. E. (1974b) The effect of barbiturate on retinal function. II. effects on the c-wave of the electroretinogram and the standing potential of the sheep eye. Acta Physiol. Scand. 91: 180-186
- Knighton, R. W. (1975) An electrically evoked slow potential of the frog's retina. I. properties of response. J. Neurophysiol. 38: 185-197



- Kohlrausch, A. (1931) Elektrische Erscheinungen am Auge. In: Handbook der normalen und pathologischen Physiologic. Ed. A. Bethe (Springer-Verlag, Berlin) Vol. XII p. 1394
- Kojima, K., Mizuno, K. & Miyazaki, M. (1958) Gamma-aminobutyric acid in ocular tissue. Nature, Lond. 181: 1200-1201
- Kolb, H. (1970) Organization of outer plexiform layer of the primate retina: Electron microscopy of Golgi-impregnated cells, Phil. Trans. Roy. Soc. Lond. B 258: 261-283
- Kolb, H. & Famiglietti, Jr., E. V. (1976) Rod and cone pathways in the retina of the cat. Invest. Ophthalmol. 15: 935-946
- Korol, S. & Owens, G. (1974) Glycine, strychnine and retinal inhibition. Experientia 30: 1161-1162
- Korol, S., Leuenberger, P. M., Englert, U. & Babel, J. (1975) In vivo effects of glycine on retinal ultrastructure and averaged electroretinogram. Brain Res. 97: 235-251
- Kramer, S. G. (1976) Dopamine in retinal neurotransmission. Chapter 8, pp. 165-198 in: Transmitters in the Visual Process. Ed. S. L. Bonting, Pergamon Press, Oxford
- Kramer, S. G. (1971) Dopamine a retinal neurotransmitter. I. retinal uptake, storage and light stimulated release of  $^3\text{H}$ -Dopamine in vivo. Invest. Ophthalmol. 10: 438-452
- Kramer, S. G., Sherman, P. A. & Seifter, J. (1967) Effects of gamma-aminobutyric acid (GABA) and sodium L-glutamate (glutamate) on the visual system and EEG of chicks. Int. J. Neuropharm. 6: 463
- Kramer, S. G., Potts, A. M. & Mangnall, Y. (1971a) Dopamine: a retinal neurotransmitter. II. autoradiographic localization of  $^3\text{H}$ -Dopamine in the retina. Invest. Ophthalmol. 10: 617-624
- Kramer, S. G., Potts, A. M. & Buffum, D. (1971b) Dopamine: a retinal neurotransmitter. III reserpine induced inhibition of electroretinographic flicker suppression. (In preparation, as cited in Kramer et al., 1971a)

- Krill, A. E., (1972) Hereditary Retinal and Choroidal Diseases Vol. I. Evaluation. Harper & Row. Hagerstown, Maryland
- Kubicek, R. & Dolinek, A. (1958) Taurine et acides amines dans la retina des animaux. J. Chromatog. 1: 266-268
- Küchler, G., Pilz, A. Sickel, W., & Bauereisen, E. (1956) Sauerstoffdruck und b-Welle des elektroretinogramms von isolierten Froschauge. Pflügers Archiv. 263: 566-576
- Kuffler, S. W. (1953) Discharge patterns and functional organization of mammalian retina. J. Neurophysiol. 16: 37-68
- Kuffler, S. W., Nicholls, J. G., and Orkand, R. K. (1966) Physiological properties of glial cells in the central nervous system of amphibia. J. Neurophysiol. 29: 290-320
- Kühne, W. (1878) On the Photochemistry of the Retina and on Visual Purple. Macmillan, New York
- Kühne, W. & Steiner, J. (1880) Über das ektromotorische Verhalten der Netzhaut. Unters. Physiol. Inst. Univ. Heidelberg. 3: 327-377
- Kuriyama, K., Siskin, B., Haber, B. & Roberts, E. (1968) The  $\gamma$ -aminobutyric system in rabbit retina. Brain Res. 9: 165-168
- Lake, N., Marshall, J. & Voaden, M. J. (1977) The entry of taurine into the neuroretina and pigment epithelium of the frog. Brain Res. 128: 497-503
- Lam, D. M. K. (1972) Biosynthesis of acetylcholine in turtle photoreceptors. Proc. Nat. Acad. Sci. USA. 69: 1987-1991
- Lange, V. (1943) Über das Vorkommen von acetylcholine im hell- und dunkel-adaptierten Auge. Z. Physiol. Chem. 279: 73-76
- Lattes, A. M. & Jacobowitz, D. (1966) Histochemical studies of monoamine containing cells in the monkey retina. J. Histochem. Cytochem. 14: 823-824

- Lederman, R. J. & Noell, W. K. (1969) Optic nerve population responses to transretinal electrical stimulation. Vision Res. 9: 1041-1052
- Leuenberger, P., Korol, S. & Babel, J. (1975) In vivo effects of glycine on retina ultrastructure and AERG. ARVO Spring Meeting Sarasota, Florida, April 30, 1975
- Levine, R. Z. (1962) Mast cells and amines in normal ocular tissues. Invest. Ophthalm. 1: 531-543
- Liberman, R. (1961) Retinal cholinesterase and glycolysis in rats raised in darkness. Science 135: 372-373
- Lindeman, V. F. (1947) The cholinesterase and acetylcholine content of the chick retina, with special references to functional activity as indicated by the pupillary constrictor reflex. Amer. J. Physiol. 148: 40-44
- Lurie, M. (1973) Aspects of interaction between retina and pigment epithelium: an electrophysiological study of the circulated frog eye. Thesis MIT 1973
- Lurie, M. (1976) Some observations on the c-wave of the electroretinogram in the intact frog eye. Exp. Eye Res. 23: 197-207
- Macaione, S., Campisi, R. & Albanese, A. (1970) Glutamate decarbossilasi  $\gamma$ -aminobutirrato transaminasi vella retina di ratto durante la crescita postnatale, Boll. del Soc. Ital. di Biol. Sper. XLVI: 1-4
- MacNicholl, E. F. & Svaetichin, G. (1958) Electric responses from the isolated retinas of fishes. Amer. J. Ophthalm. 46: 26-46
- Maggiano, J. M., Marchese, A. L. & Friedman, A. H. (1975) The electrooculogram in response to near UV and near IR. Abstract, ARVO Spring Meeting, Sarasota, Florida April 30, 1975
- Malmfors, T. (1963) Evidence of adrenergic neurons with synaptic terminals in the retina of rats demonstrated with fluorescein and electron microscope. Acta. Physiol. Scand. 58: 99-100
- Maraini, G., Carta, F. & Franguelli, R. (1969) Metabolic changes in the retina and optic centres following monocular light deprivation in the new born rat. Exp. Eye Res. 8: 55-59

- Marchese, A. L. & Friedman, A. H. (1973a) Time-lapse recorded ERGs in the isolated perfused poikilotherm and homoiotherm eye. Federation Proceedings 32: 372
- Marchese, A. L. & Friedman, A. H. (1973b) Reversal by bicuculline of the simulated state of light adaptation produced by GABA in the dark-adapted, isolated eye perfused through its ophthalmic artery. The Pharmacologist 15: (2) 162
- Marczynski, Thaddeus J. (1976) Serotonin and the CNS in Chemical Transmission in the Mammalian CNS. 349-429. Eds. C. H. Hockman and D. Biegler, University Park Press, Baltimore
- Marshall, J. & Voaden, M. (1974) An autoradiographic study of cells accumulating  $^3\text{H}$   $\gamma$ -aminobutyric acid in the isolated retinas of pigeons and chickens. Invest. Ophthalmol. 13: 602-607
- Matsumoto, N. & Naka, K. I. (1972) Identification of intracellular responses in the frog retina. Brain Res. 42: 59-71
- Maturana, H. R., Lettvin, W., McCulloch, & Pitts, W. (1960) Anatomy and physiology of vision in the frog (Rana pipiens). Jour. Gen. Physiol. 43: Suppl. 2 120-175
- Mayer (1902) Die muskularisierung der capillarey blutgefusse Anat. Anz. 21: 442-455
- Meier-Ruge, W. (1972) Drug Induced Retinopathy. CRC Critical Reviews in Toxicology 325-360
- Miller, R. F. (1973) Role of  $\text{K}^+$  in generation of b-wave of electroretinogram. J. Neurophysiol. 36: 28-38
- Miller, R. F. & Dowling, J. E. (1970) Intracellular responses of the Müller (glial) cells of mudpuppy retina: Their relation to the b-wave of the electroretinogram. J. Neurophysiol. 33: 323-341
- Mita, T., Inomata, K., Sugawara, Y. & Sato, T. (1969) Studies on the standing potential of the retina in rabbit and cat. Jap. J. Physiol. 19: 360-372
- Motakawa, K. & Mita, T. (1942) Über eine einfachere Untersuchungsmethode und eigenschaften der Aktionströme der Netzhaut der Menschen. Tohoku. J. Exp. Med. 42: 114-133

- Murakami, M. & Kaneko, A. (1966) Sub-components of PIII in cold blooded vertebrate retinae. Nature 210: 103-104
- Murakami, M., Ohtsu, K. & Ohtsuka, T. (1972) Effects of chemicals on receptors and horizontal cells in the retina. J. Physiol. 227: 899-913
- Murakami, M., Ohtsuka, T. and Shimazaki, H. (1975) Effects of aspartate and glutamate on bipolar cells in the carp retina. Vision Res. 15: 456-458
- Nace, G. W. (1976) Caretakers Corner. The frog and other amphibians. Lab. Animals. 5: 52-54
- Naka, K. I. (1972) The horizontal cells. Vision Res. 12: 573-588
- Narahashi, T. (1974) Chemicals as tools in the study of excitable membranes. Physiol. Rev. 54: (4) 814-889
- Neal, M. J. (1976a) Amino acid transmitter substances in the vertebrate retina. Gen. Pharmac. 7: 321-332
- Neal, M. J. (1976b) Acetylcholine as a retinal transmitter substance. In: Transmitters in the Visual Process. Ed. S. L. Bonting. Pergamon Press, Oxford, New York
- Nichols, C. W. & Koelle, G. B. (1968) Comparison of the localization of acetylcholinesterase and non-specific cholinesterase activities in mammalian and avian retinas. J. Comp. Neurol. 133: 1-15
- Nicholson, C. (1973) Theoretical analysis of field potentials in anisotropic ensembles of neuronal elements. IEEE Trans. Biomed. Eng. BME 20: 278-288
- Niemeyer, G. (1975) The function of the retina in the perfused eye. Documenta Ophthalmologica. 39,1: 53-116
- Niemeyer, G. (1976) C-waves and intracellular responses from the pigment epithelium in the cat. Electrooculography - Its Clinical Importance Biblihca. Ophthalm. 85: 68-74
- Niemeyer, G. (1977) The perfused cat eye: a model in neurobiologic research. Albrecht v. Graefes Arch. klin. exp. Ophthalm. 203: 209-216

- Niemeyer, G. & Gouras, P. (1973) The perfused mammalian eye as a preparation for electrophysiological studies. Doc. Ophthalmologica Proceedings of the Xth I.S.C.E.R.G. Symposium. 261-268
- Niemeyer, G. & Cervetto, L. (1977) Effects of atropine on ERG and optic nerve response in the cat. Doc. Ophth. Proc. Series ERG, VER and Psychophysics, XIV I.S.C.E.R.G. Symp. 13: 307-314
- Noell, W. K. (1951) The effect of iodoacetate on the vertebrate retina. J. Cell. Comp. Physiol. 37: 283-307
- Noell, W. K. (1953) Studies on the electrophysiology and the metabolism of the retina. U.S.A.F. School of Aviation Medicine Project No. 21-1201-0004, Report #1, 122
- Noell, W. K. (1959) The visual cell: electrical and metabolic manifestations of its life processes. Am. J. Ophthal. 48: 347-370
- Noell, W. K. & Chin, H. I. (1950) Failure of the visual pathway during anoxia. Am. J. Physiol. 161: 573-590
- Noell, W. K. & Lasansky, A. (1959) Effects of electrophoretically applied drugs and electrical currents on the ganglion cell of the retina. Fed. Proc. 18: 115
- Nosaki, Hiroshi (1973) The uptake of various transmitter-suspects or precursors by retinal cells. (Spon. T. Sourkes). McGill Univ., Montreal, Canada. Fed. Proc. 32: 695 (abs 271r)
- Oakley, II, B. & Green, D. G. (1976) Correlation of light-induced changes in retinal extracellular potassium concentration with c-wave of the electroretinogram. J. Neurophysiol. 39: 1117-1133
- Ogden, T. (1973) The oscillatory waves of the primate electroretinogram. Vision Res. 13: 1059-1074
- Ogden, T. & Wylie, R. (1971) Avian retina: I. micro-electrode depth and marking studies of local ERG. J. Neurophysiol. 34: 357-366
- Orkand, R. K., Nicholls, J. G. & Kuffler, S. W. (1966) Effect of nerve impulses on the membrane potential of glial cells in the central nervous system of amphibia. J. Neurophysiol. 29: 788-806

- O'Rourke, J. & Berghoffer, B. (1968) Uveal extraction and clearance of oxygen in normal, inflamed and hypothermic eyes. Ophthalmologica. 155: 205-216
- Osborne, M. P. & Thornhill, R. A. (1972) The effect of monoamine depleting drugs upon the synaptic bars in the inner ear of the bullfrog (Rana catesbeiana). Z. Zellforsch. 127: 347-355
- O'Steen, W. K. and Vaughan, G. M. (1968) Radioactivity in the optic pathway and hypothalamus of the rat after intraocular injections of tritiated 5-hydroxytryptophan. Brain Res. 8: 209-212
- Ottoson, D. & Svaetichin, G. (1952) Electrophysiological investigations of the frog retina. Cold Spring Harbor Symposium Quant. Biol. 17: 165-173
- Ottoson, D. & Svaetichin, G. (1953) Electrophysiological investigations of the origin of the ERG of the frog retina. Acta. Physiol. Scand. 106: 538-564
- Ozaki, Y., & Wurtman, R. J. (1979) Spectral power distribution of light sources affects growth and development of rats. Photochem. & Photobiol. 29: 339-341
- Pasantes-Morales, H., Kleithi, J., Ledig, M. & Mandel, P. (1972) Free amino acids of chicken and rat retina. Brain Res. 41: 494-497
- Pasantes-Morales, H., Bonaventure, N., Wioland, N. & Mandel, P. (1973) Effect of intravitreal injection of taurine and GABA on chicken electroretinogram. Int. J. Neurosci. 5: 235-241
- Penn, R. D. & Hagins, W. A. (1969) Signal transmission along retinal rods and the origin of the electroretinographic a-wave. Nature 223: 201-205
- Penn, R. D. & Hagins, W. A. (1972) Kinetics of the photocurrent in retinal rods. Biophys. J. 12: 1073-1094
- van Peski, A. C. H., deVooy, D. A. & Engle, D. C. (1969) Transient changes in the potential of the Ag-AgI electrode induced by a light pulse. Nature 223: 177

- Phillis, J. W., Tebecis, A. K. (1967) The effects of topically-applied cholinomimetic drugs on the isolated spinal cord of the toad. Comp. Biochem. Physiol. 23: 541-552
- Pickering, S. G. (1968) The extremely long latency response from ON-OFF retinal ganglion cells: relationship to dark-adaptation. Vision Res. 8: 383-387
- Pickering, S. G. & Varju, D. (1967) Ganglion cells in the frog retina: inhibitory receptive field and long latency response. Nature, Lond. 215: 545-546
- Pickering, S. G. & Varju, D. (1969) Delayed responses of ganglion cells in the frog retina: the influence of stimulus parameters upon the length of the delay time. Vision Res. 9: 865-879
- Piper, H. (1911) Über die Netzhautströme, Arch. Anat. Physiol. Lpz. (Physiol Abt.) 85-132
- Pirie, A. & Van Heyningen, R. (1956) Chemical aspects of vision. In: the Biochemistry of the Eye. Oxford. p. 176
- Polyak, S. L. (1941) The Retina. University of Chicago Press, Chicago
- Pomerantz, G. and Sorrentino, S. (1973) The influence of melatonin administered subcutaneously, intravenously and intraocularly upon ovulation in the PMS-treated immature ret. Neuroendocrin. 12: 353-361
- Potts, A. M. & Gonasun, L. M. (1975) Toxicology of the Eye. Chapter 13. Ed. Casarett & Doull. 275-309
- Pourcho, R. G. (1977) Distribution of (<sup>35</sup>S) Taurine in mouse retina after intravitreal and intravascular injection. Exp. Eye. Res. 25: 119-127
- Quay, W., (1965) Retinal and pineal hydroxyindole-o-methyltransferase activity in vertebrates. Life Science. 4. 983-991
- Racagni, G., Bruno, F., Cattabeni, F., Maggi, A., & Gropetti, A., (1978) Interactions among dopamine, acetylcholine, and GABA in the nigrostriatal system. Interactions Between Putative Neurotransmitters in the Brain, Ed. by S. Garattini, J. F. Pujol, and R. Samanin, Raven Press, New York, C. 1978



- Raviola, E. and Raviola, G. (1962) Ricerche istochimiche sulla retina di coniglia nel corso dello sviluppo postnatale. Z. Zellforsch Anat. mikrosk. 56: 552-572
- Raviola, E. & Gilula, N. B. (1975) Intramembrane organization of specialized contacts in the outer plexiform layer of the retina; a freeze fracture study in monkeys and rabbits. J. Cell Biol. 65: 192-222
- Reale, E., Luciano, L. & Spitznas, M. (1971) The fine structural localization of acetylcholinesterase activity in the retina and optic nerve of rabbit. J. Histochem. Cytochem. 19: 85-96
- Rodieck, R. W. (1973) The Vertebrate Retina, Principles of Structure and Function. Freeman, San Francisco
- Rodieck, R. W. & Ford, R. W. (1969) The cat local electroretinogram to incremental stimuli. Vision Res. 9: 1-24
- Rouget, C. (1873) Memoire sur le developement, la structure et las proprietes physiologiques des capillares sanguines et lymphatiques. Archives de Physiol. V: 603-663
- Rushton, W. A. H. (1965) Bleached rhodopsin and visual adaptation. J. Physiol. 181: 645-655
- Ruskell, G. L. (1971) Facial parasympathetic innervation of the choroidal blood vessels in monkeys. Exptl Eye Res. 12: 166-172
- Sano, K., Miyake, H., & Mayangi, Y. (1967) Steady potentials in various stress conditions in man. Electroencephalograph & Clin. Neurol. Suppl. 25. Recent advances in Clinical Neurophysiology, Ed. L. Widen 264-275
- Schmitt, F. O., Dev, P. & Smith, D. (1976) Electronic processing of information by brain cells. Science 193: 114-120
- Scholes, N. W. & Roberts, E. (1964) Pharmacological studies of the optic system of the chick: the effects of  $\gamma$ -aminobutyric acid and pentobarbital. Biochem. Pharmacol. 13: 1319-1329

- Schubert, G. & Bornschein, H. (1952) Beitrag zur Analyse des menschlichen Elektoretinogramms. Ophthalmologica, 123: 396-413
- Schwartz, J. C. (1977) Histaminergic mechanism in brain. Ann. Rev. Pharmacol. Toxicol. 17: 325-339
- Seaman, A., Rullman, D., Lutcher, C. & Moffat, C. (1965) The living extracorporeal eye. Scand. J. Clin. & Lab. Invest. 17: Suppl. 84, 101-108
- Seaman, A., Lutcher, C. & Moffat, C. (1969) Intravascular hemagglutination studies with the living extracorporeal eye. Blood 33: 13-25
- Seaman, A., Mariscal, I. & Moffat, C. (1971) Intravascular observations of fibrinolysis in an isolated organ. Sonderdruck aus. Thrombolytic Therapy
- Sickel, W. (1972) Retinal Metabolism in Dark and Light. in Handbook of Sensory Physiology Volume VII/2 Physiology of Photoreceptor Organs Ed. M.G.F. Fuortes Springer-Verlag Berlin, Heidelberg. New York
- Sickel, W. & Crescitelli, F. (1967) Delayed electrical responses from the isolated frog retina. Pflügers Arch. Ges. Physiol. 297: 266-269
- Sjöstrand, F. S. (1949) An electron microscope study of the retinal rods of the guinea pig. J. Cell Comp. Physiol. 33: 383-403
- Sjöstrand, F. S. (1958) Ultrastructure of rod retinal synopsis of the guinea pig eye as revealed by three-dimensional reconstructions from serial sections. J. Ultrastruct. Res. 2: 122-170
- Skoog, K. O. (1974) On the c-wave and the standing potential of the human eye. Linköping University Medical Dissertation No. 27, Department of Ophthalmology, University of Linköping, Linköping, Sweden
- Somjen, G. G., (1973) Electrogenesis of sustained potentials. Progress in Neurobiology V. 1 part 3 Ed. Kerkut, G. & Phillis, J. Pergamon Press, Oxford & N. Y. 1973
- Starr, M. S. (1973) Effect of dark-adaptation of the GABA system in retina. Brain Res. 59: 331-338

- Starr, M. S. (1975) The effect of various amino acids dopamine and some convulsants on the electroretinogram of the rabbit. Exp. Eye Res. 21: 79-87
- Starr, M. & Voaden, M. J. (1972) The uptake of (<sup>14</sup>C)  $\gamma$ -aminobutyric acid by the isolated retina of the rat. Vision Res. 12: 549-557
- Steinberg, R. H., Schmidt, R. & Brown, K. T. (1970) Intracellular responses to light from cat pigment epithelium: origin of the electroretinogram c-wave. Nature 227: 728-730
- Steinberg, R. H. & Miller, S. (1973) Aspects of electrolyte transport in frog pigment epithelium. Exp. Eye Res. 16: 362-365
- Stell, W. K. (1967) The structure and relationship of horizontal cells and photoreceptor - bipolar synaptic complexes in goldfish retina. Amer. J. Anat. 121: 401-423
- Stell, W. K. (1972) The morphological organization of the vertebrate retina. In: Handbook of Sensory Physiology. Vol. VII, P2, pp. 111-213, Ed. M. G. F. Fuortes Springer-Verlag, Berlin
- Stell, W. K. (1976) Functional polarization of horizontal cell dendrites in goldfish retina. Invest. Ophthalmol. 15: 895-908
- Stell, W. K. & Lightfoot, D. O. (1975) Color specific interconnections of cones and horizontal cells in the retina of the goldfish. J. Comp. Neurol. 159: 473-489
- Stone, J. & Hoffman, K. D. (1972) Very slow conduction ganglion cells in the cat's retina; a major new functional type? Brain Res. 43: 610-616
- Straschill, M. (1968) Actions of drugs on single neurons in the cat's retina. Vision Res. 8: 35-47
- Straschill, M. & Perwein, J. (1969) The inhibition of retinal ganglion cells by catecholeamines and  $\gamma$ -aminobutyric acid. Pflügers. Arch. 312: 45-54
- Svaetichin, G. (1953) The cone action potential. Acta Physiol. Scand. 29: Suppl. 106: 565-599

- Svaetichin, G. (1956) Spectral responses from single cones. Acta Physiol. Scand. 39: 17-46
- Täumer, R., Hennig, J. & Pernice, D. (1974) The ocular dipole - a damped oscillator stimulated by the speed of change in illumination. Vision Res. 14: 637-645
- Tazawa, Y. & Seaman, A. J. (1969) Recording the electroretinogram in the living extracorporeal eye. Invest. Ophthalmol. 8: 238-239
- Tazawa, Y., Marascal, I., Moffat, C., Huebner, B. & Seaman, A. (1971) The endothelial role in thrombosis. Induced retinal vasculitis in the living extracorporeal eye. Invest. Ophthalmol. 10: 481-488
- Tazawa, Y. & Seaman, A. J. (1972) The electroretinogram of the living extracorporeal bovine eye. The influence of anoxia and hypothermia. Invest. Ophthalmol. 11: 691-698
- Tazawa, Y., Takahashi, Y., Otsuka, T. & Matsuda, K. (1977) Relationship between ERG and O<sub>2</sub> consumption in the isolated perfused bovine eye. Doc. Ophthalmol. Proc. Series ERG, VER and Psychophysics. 14th I.S.C.E.R.G. Symp. 13: 315-328
- Therman, P. O. (1938) The neurophysiology of the retina in the light of chemical methods of modifying its excitability. Act. Soc. Sci. Fenn. Ser. B(2): 5-74
- Tirala, L. (1917) Die physiologischen Vorgänge in der Netzhaut und ihre Deutung auf Grund neuer Methoden. Arch. Anat. Physiol. Lpz. 121-169
- Tomita, T. (1950) Studies on the intraretinal action potential. Part I. Relation between the localization of micropipette in the retina and the shape of the intraretinal action potential. Jap. J. Physiol. 1: 110-117
- Tomita, T. (1976) Electrophysiological studies of retinal cell function. Invest. Ophthalmol. 15: 171-187
- Tomita, T., Funaishi, A. and Shino, H. (1951) Studies on intraretinal action potential—II. Effects of some chemical agents upon it. Jap. J. Physiol. 2: 147-153

- Tomita, T. & Torihama, Y. (1956) Further study on the intraretinal action potentials and on the site of ERG generation. Jap. J. Physiol. 6: 118-136
- Toyoda, J., Nosaki, H. & Tomita, T. (1969) Light-induced resistance changes in signal photoreceptors of Necturus and Gekko. Vision Res. 9: 453-463
- Trifonov, Y. A. (1968) Study of synaptic transmission between photoreceptors and horizontal cells by means of electric stimulation of the retina. Biofizika. 13: 809-817
- Tsacopoulos, M., Baker, R. & Hamasaki, D., et al. (1973) Proceedings: Studies on retinal blood flow regulation: the effect of PaCO<sub>2</sub> on blood flow, oxygen availability, oxygen consumption rate and ERG in monkeys. Exp. Eye Res. 17: 391
- Urban, P. F., Dreyfus, H. & Mandel, P. (1976) Influence of various amino acids on the bioelectric response to light stimulation of a superfused frog retina. Life Sci. 18: 473-480
- Val'Tsev, V. B. (1966) Role of cholinergic structures in outer plexiform layer in the electrical activity of frog retina. Fed. Proc. 25: (Transl. Suppl) T765-T766
- VanHarrevald, A. (1977) Pharmacology of the vertebrate retina. Prog. Neurobiol. 8: 1-43
- Voaden, M. J. (1976) Gamma-aminobutyric acid and glycine as retinal neurotransmitters. In: Transmitters in the Visual Process. Ed. S. L. Bonting. Pergamon Press. Oxford
- Voaden, M. J. & Starr, M. S. (1972) The efflux of radioactive GABA from rat retina in vitro. Vision Res. 12: 559-566
- Voaden, M. J., Lake, N., Marshall, J. & Morjaria, B. (1977) Studies on the distribution of Taurine and other neuroactive amino acids in the retina. Exp. Eye Res. 25: 249-257
- Von Bredow, J., Bay, E. and Adams, N. (1971) Drug actions on the central nervous system as studied by the effects on the electroretinogram. Exp. Neurol. 33: 45-52

- Wachtmeister, L. & Dowling, J. (1978) The oscillatory potentials of the mudpuppy retina. Invest. Opth. 17: 1176-1188
- Wagner, H. J. (1973) Darkness-induced reduction of the number of synaptic ribbons in fish retina. Nature New Biology 246: 53-55
- Wald, G. & Brown, P. K. (1950) The synthesis of rhodopsin from retinene. Proc. Natl. Acad. Sci. USA 36: 84-92
- Walker, C. A. & Friedman, A. H. (1972) The acute toxicity of drugs acting at cholinceptive sites and twenty-four hour rhythms in brain acetylcholine. Arch Toxikol 29: 39-49
- Welsh, J. H. (1964) The quantitative distribution of 5-hydroxytryptamine in the nervous system, eyes and other organs of some vertebrates. In: Comparative Neurochemistry. Ed. D. Richter. pp. 355-366. Pergamon Press, Oxford
- Werblin, F. S. (1973) Organization of the vertebrate retina. In: The Eye Eds. H. Davson & L. T. Graham, Jr. Vol. 6, pp 257-281. Acad. Press, New York
- Werblin, F. & Dowling, J. E. (1969) Organization of the retina of the mudpuppy, Necturus maculosus. II. Intracellular recording. J. Neurophysiol. 32: 339-355
- Werblin, F. S. & Copenhagen, D. R. (1974) Control of retinal sensitivity. III. Lateral interactions at the inner plexiform layer. J. Gen. Physiol. 63: 88-110
- Wong, V. & Macri, F. (1964) Vasculature of the cat eye. Arch. Ophthal. 72: 351-358
- Wu, J. Y. & Roberts, E. (1974) Properties of brain L-glutamate decarboxylase inhibition studies. J. Neurochem. 23: 759-767
- Wyatt, H. J. & Daw, N. W. (1976) Specific effects of neurotransmitter antagonists on ganglion cells in rabbit retina. Science 191: 204-205
- Yates, R. A. & Keen, P. (1976) The distribution of free amino acids in subdivision of rat and frog retinae obtained by a new technique. Brain Res. 107: 117-126

- Yazulla, S. & Schmidt, J. (1976) Radioautographic localization of  $^{125}\text{I}$   $\alpha$ -bungarotoxin binding sites in the retinas of goldfish and turtle. Vision Res. 16: 878-880
- Yessaian, N. H. M., Armenian, A. R. & Buniatian, H. Ch. (1969) Effect of GABA on serotonin and catecholamines. J. Neurochem. 16: 1425-1433
- Yonemura, D., Masuda, Y. & Hatta, M. (1963) The oscillatory potential in the electroretinogram. Jap. J. Physiol. 13: 129-137
- Yonemura, D. & Hatta, M. (1966) Localization of the minor components of the frog's electroretinogram. Jap. J. Ophthal. 10: Suppl. (Proc. 4th I.S.C.E.R.G. Symp.) 149-154
- Yoshikami, S. & Hagins, W. A. (1973) Control of dark current in vertebrate rods and cones. In: Biochemistry and Physiology of Visual Pigments. Ed., H. Langer, Springer-Verlag, Berlin
- Young, R. W. (1969) The organization of vertebrate photoreceptor cells. In: The Retina: Morphology, Function and Clinical Characteristics. Ed., B. R. Stratsma, M. O. Hall, R. A. Allen & F. Crescitelli. pp. 177-210. University of California Press, Los Angeles

## APPENDIX A



TABLE V      Rate of change ( $dy/dt$ ) of  
the standing potential of the optic nerve  
in  $\mu V/min$  after ions or drugs

<u>Drug (Ion)</u>	<u>Molar Conc.</u>	<u><math>dy/dt</math> (<math>\mu V/min</math>)</u>	
		<u>A. Initial</u>	<u>B. Other</u>
$K^+$	$4 \times 10^{-3}$	$\uparrow 100$	$\uparrow 34$
$Ca^{++}$	$2 \times 10^{-4}$	$\uparrow 100$	
NE	$10^{-3}$	$\downarrow 100$	$\uparrow 44, \downarrow 135, \uparrow 85$
5-HT	$10^{-3}$	$\uparrow 125$	
ACh	$10^{-3}$	$\uparrow 109$	
GABA	$10^{-3}$	$\uparrow 400$	
Histamine	$10^{-3}$	$\downarrow 84$	
l-DOPA	$10^{-3}$	$\uparrow 550$	
Dopamine	$10^{-3}$	$\downarrow 71$	
Glycine	$10^{-3}$	$\downarrow 42$	
1st dose NaAzide	$1.4 \times 10^{-5}$	$\uparrow 75$	
2nd dose NaAzide	$1.4 \times 10^{-5}$	$\uparrow 34$	

$\uparrow$  indicates negative-going change

$\downarrow$  indicates positive-going change

Total change in SP during experiment 28.4 mv

Interval between drugs, 20 minutes

APPENDIX B

Composition of physiological saline solutions used  
to perfuse the frog isolated eye preparation

Concentration in mM/liter

	Sickel* (1972)	Clark Gaddum 1953	Phillis & Tebecis (1967)
NaCl	80.0	111.21	100.0
KCL	2.0	1.88	2.5
CaCl <sub>2</sub>	0.1	1.00	1.9
Na <sub>2</sub> HPO <sub>4</sub>	13.5	--	2.5
NaH <sub>2</sub> PO <sub>4</sub>	1.5	0.08	0.45
MgCl <sub>2</sub>	0.1	--	--
NaHCO <sub>3</sub>	--	1.92	12.0
Glucose	5.0	11.10	2.8
Aerating gas	air	air	95% O <sub>2</sub> 5% CO <sub>2</sub>

\* Modified Sickel's medium:  
as above + fetal calf serum---2%  
aerating gas---O<sub>2</sub> (100%)

Cat: Eagle's basal medium with 10% fetal calf serum  
(tissue culture medium). (Eagle, 1959)

## APPENDIX C

## APPENDIX C

Miscellaneous Drug Effects

The following group of drugs usually administered in a single dose to non-naive preparations was examined as a part of the general survey of drug effects: neostigmine ( $3.0 \times 10^{-4}M$ ); d-tubocurarine ( $2.2 \times 10^{-3}M$ ); atropine ( $9.2 \times 10^{-5}M$  and  $1.0 \times 10^{-4}M$ ); reserpine ( $4.1 \times 10^{-3}M$ ); Tremorine ( $1.7$  and  $1.2 \times 10^{-3}M$ ); Oxotremorine ( $1.6 \times 10^{-3}M$ ) and Tetrodotoxin ( $1 \times 10^{-6}M$ ). The effects will be summarized insofar as they were measurable at the time of administration.

Neostigmine increased the "c"-wave amplitude and moved the SP (optic nerve) in a negative-going direction.

d-Tubocurarine produced a biphasic effect on the "c"-wave and moved the SP (eye) in a negative-going direction. It was without effect on the c-wave and SP (optic nerve).

Reserpine uniquely generated a single, "b"-wave, "c"-wave and c-wave. The SP (optic nerve) moved in a positive direction while the SP (eye) was biphasic in its response.

Atropine moved the SP (eye) in a negative direction, decreased the c-wave while increasing the "b"-wave amplitude. The b-wave, however, was stable. In another preparation the b- and d-waves were depressed while the "b"-wave amplitude was augmented. The SP (optic nerve) moved in a positive direction.

Tremorine and Oxotremorine Tremorine, a parkinsonimimetic in doses of  $1.7$  and  $1.2 \times 10^{-3}M$  (Figure 30) produces a striking biphasic effect on the eye's SP in which the first phase moves in a negative and the second phase in a positive-going direction. The optic nerve SP moves positive with the first dose, negative with the second. The c-wave initially depressed, recovers followed by further depression. Oxotremorine ( $1.6 \times 10^{-3}M$ ) a muscarinic agent, is remarkably inactive.

Tetrodotoxin (TTX) TTX is a total dose of  $1 \times 10^{-6}M$  produced a number of effects on the potentials of the eye and its optic nerve. The SP of the optic nerve in this sucrose gap preparation was moving in a positive-going direction

## Appendix C (Cont'd)

at a  $dy/dt$  of 0.24 mV/minute during the control. After TTX the rate decreased to 0.07 mV/minute, leveled and reached a stabilized state with  $dy/dt = 0$  mV/min. (TEA,  $1 \times 10^{-6}$  M given subsequently reversed the SP of the optic nerve moving it in a negative-going direction,  $dy/dt = 0.995$  mV/min.). Both the b- and d-waves of the ERG were reduced in amplitude by TTX 61 and 37% respectively. The c-wave was unaffected. The "b" and "d"-wave amplitude of the ONP were only slightly changed by the administration of TTX.

APPROVAL SHEET

The dissertation submitted by Anthony L. Marchese has been read and approved by the following committee:

Dr. Alexander H. Friedman, Director  
Professor, Pharmacology, Loyola

Dr. Silas N. Glisson  
Associate Professor, Anesthesiology  
and Pharmacology, Loyola

Dr. James E. McDonald  
Professor and Chairman, Ophthalmology, Loyola

Dr. Robert S. Schmidt  
Associate Professor, Pharmacology, Loyola

Dr. Robert D. Wurster  
Professor, Physiology, Loyola

The final copies have been examined by the director of the dissertation and the signature which appears below verifies the fact that any necessary changes have been incorporated and that the dissertation is now given final approval by the Committee with reference to content and form.

The dissertation is therefore accepted in partial fulfillment of the requirements for the degree of Doctor of Philosophy.

13 December 1979  
Date

Alexander H. Friedman  
Director's Signature