



1966

A Quantitative Study on Analogues of the Biophysics of Resisting Forces and Stresses That Correspond to the Horizontal Fibers of a Periodontal Ligament

Bruce M. Nakfoor
Loyola University Chicago

Follow this and additional works at: https://ecommons.luc.edu/luc_theses



Part of the [Medicine and Health Sciences Commons](#)

Recommended Citation

Nakfoor, Bruce M., "A Quantitative Study on Analogues of the Biophysics of Resisting Forces and Stresses That Correspond to the Horizontal Fibers of a Periodontal Ligament" (1966). *Master's Theses*. 2055.
https://ecommons.luc.edu/luc_theses/2055

This Thesis is brought to you for free and open access by the Theses and Dissertations at Loyola eCommons. It has been accepted for inclusion in Master's Theses by an authorized administrator of Loyola eCommons. For more information, please contact ecommons@luc.edu.



This work is licensed under a [Creative Commons Attribution-Noncommercial-No Derivative Works 3.0 License](#).
Copyright © 1966 Bruce M. Nakfoor

A QUANTITATIVE STUDY ON ANALOGUES OF THE BIOPHYSICS OF
RESISTING FORCES AND STRESSES THAT CORRESPOND
TO THE HORIZONTAL FIBERS OF A
PERIODONTAL LIGAMENT

by

BRUCE M. NAKFOOR

A Thesis Submitted to the Faculty of the Graduate School
of Loyola University in Partial Fulfillment of
the Requirements for the Degree of
Master of Science

JUNE

1966

LOYOLA UNIVERSITY MEDICAL CENTER

PREFACE

The purpose of this research was to investigate the resisting forces and stresses that develop in the HORIZONTAL FIBERS of the periodontal ligament when single forces of known magnitudes were applied to the crown of a tooth. Since it is impossible to conduct an investigation of this scope on patients, analogues were constructed. The investigation was conducted in conjunction with a fellow graduate student, Dr. James A. Evans, who studied resisting forces and stresses that develop in the APICAL FIBERS. Although there is a close relationship of the two areas of study, the differences are in the formulas used and the magnitudes of deflections, forces and stresses encountered.

This work is one step in a continuing investigation of the biophysics of the periodontal ligament and the general problem of tooth movement.

ABOUT THE AUTHOR

Bruce M. Nakfoor was born in Lansing, Michigan, on March 6, 1930. He received his secondary education at St. Mary's School in Lansing, Michigan, and upon graduating in 1947, he received an appointment to the United States Military Academy at West Point, New York. He continued his undergraduate studies at Michigan State University, East Lansing, Michigan. In September, 1953, the author entered Georgetown University School of Dentistry, Washington, D.C., and graduated in June, 1957, with the degree of Doctor of Dental Surgery.

From 1957 to 1959 the author served as a commissioned dental officer in the United States Air Force on active duty on Okinawa. He practiced dentistry in Lansing, Michigan, from 1959 to 1964. Since June of 1964, he has been enrolled in the Department of Oral Biology at Loyola University, Chicago, Illinois, working toward a Master of Science Degree.

He is married and has a daughter and a son.

ACKNOWLEDGMENTS

My sincere appreciation is extended to all those who in any way aided in this investigation, particularly to the following:

First, I wish to extend my sincere gratitude to my advisor and teacher, Joseph R. Jarabak, D.D.S., Ph.D., Professor of Orthodontics, Loyola University, for his invaluable guidance during this investigation.

I am most grateful to James A. Fizzell, B.S. in E.E., for his technical advise and assistance in the construction of the analogues, the analysis of the data and for his extensive knowledge of mathematics in the formulation of the formulas used in this work.

I am thankful to Vincent Sawinski, Ph.D., for serving as a member of my advisory board.

I also wish to thank my wife, Gloria, for her interest, encouragement, and great personal sacrifices, without which this study could not have been completed.

TABLE OF CONTENTS

Chapter	Page
LIST OF FIGURES	viii
LIST OF TABLES	ix
I. INTRODUCTION:	1
A. INTRODUCTORY REMARKS	1
B. STATEMENT OF THE PROBLEM	2
II. REVIEW OF THE LITERATURE	3
III. METHODS AND MATERIALS:	16
A. Patient selection	
B. Construction of biometric apparatus to study <u>in vivo</u> tooth movements	
C. Material selection	
D. Analogues used for quantitative study of stresses	
E. Mounting of two-dimensional analogue into measuring device	
F. Compressive and tensile stresses	
G. Force analysis for compression and tension	
H. Shear analysis	
I. Compressive and tensile stress analysis on Model II	
J. Shear analysis on Model II	
K. Construction of three-dimensional analogue	

Chapter	Page
IV. EXPERIMENTAL RESULTS:	41
A. Evaluation of the stress deflection characteristics of six <u>in vivo</u> periodontal ligaments	
B. Evaluation of material selected	
C. Evaluation of resisting forces produced by single forces on Model I	
D. Evaluation of stresses when a single force was applied to Model II	
E. Evaluation on Model III for resisting forces when single forces were applied	
F. Evaluation of Model IV for stress when single forces were applied	
V. DISCUSSION:	55
A. The force-deflection characteristics of an <u>in vivo</u> periodontal ligament obtained from six patients	
B. Assessment of resisting forces in the Horizontal Fibers on a two-dimensional model	
C. Assessment of stresses in the Horizontal Fibers on a two-dimensional model	
D. Assessment of resisting forces in the Horizontal Fibers on a three-dimensional model	
E. Assessment of stress in the Horizontal Fibers on a three-dimensional model	
F. Appraisal of theoretical determination of the center of tipping	
G. The amount of compression, tensile, and shear stresses that develop and the significance of each one	
VI. SUMMARY AND CONCLUSIONS	66

Chapter	Page
APPENDICES	70
GLOSSARY	89
BIBLIOGRAPHY	92

LIST OF FIGURES

Figure	Page
1. MANDIBULAR PORTION OF CLUTCH	18
2. COMPLETED CLUTCH	18
3. COMPLETED CROWN ON MODEL	19
4. COMPLETED BIOMETRIC APPARATUS	19
5. BIOMETRIC APPARATUS IN MOUTH	21
6. POSITION OF SENSING ARM ON ARTICULATOR	21
7. MEASUREMENTS IN THE MOUTH	22
8. MACHINED PLASTIC HUBS	25
9. TESTING MACHINE WITH SPECIMEN MOUNTED FOR COMPRESSION TEST . . .	26
10. SPECIMEN BEING TESTED FOR SHEAR	26
11. TWO-DIMENSIONAL MODEL	29
12. TWO-DIMENSIONAL MODEL SEATED IN MEASURING DEVICE	29
13. DIAGRAM OF TWO-DIMENSIONAL ANALOGUE	32
14. DIAGRAM OF THREE-DIMENSIONAL ANALOGUE.	37
15. THREE-DIMENSIONAL MODEL	39
16. THREE-DIMENSIONAL MODEL SEATED IN MEASURING DEVICE	39
17. GENERAL TOOTH DEFLECTIONS THAT OCCURRED WHEN KNOWN FORCE MAGNITUDES WERE APPLIED	63

LIST OF TABLES

Table	Page
I. ANALYSIS OF VARIANCE	44
II. MODEL I: MEASUREMENT IN COMPRESSION AND TENSION FOR RESISTING FORCES	46
III. MODEL I; MEASUREMENT IN SHEAR	47
IV. MODEL II: MEASUREMENT IN COMPRESSION AND TENSION FOR RESISTING FORCES	49
V. MODEL II: MEASUREMENT IN SHEAR	50
VI. MODEL III: MEASUREMENT OF RESISTING FORCE	52
VII. MODEL IV: MEASUREMENT OF STRESS	53

CHAPTER I
INTRODUCTION

A. INTRODUCTORY REMARKS

Orthodontic appliances are force producing devices. When the appliances are activated, they apply forces to the crowns of the teeth. These forces have magnitude and direction and can be accurately controlled. Once a force is applied to the crown of a tooth, it is distributed to the periodontal ligament as stress. The distribution of stresses placed on the periodontal ligament is not clearly understood.

To obtain a more accurate perspective regarding these stresses, research must be directed toward a better understanding of stresses. It is logical, then, to think of orthodontic tooth movement in terms of a biophysical phenomenon. Biophysics may be described as encompassing three fields of endeavor. These are (1) to use physics to explain biological phenomena, (2) to study the effects of physical environmental agents on biological material, and (3) to use physical instruments, models, and techniques to study biological systems. It is obvious that it will be necessary to employ these principles in the measurement and statistical evaluation of data obtained from this sophisticated system.

In approaching a study of this nature, one must keep in mind the words of the well-known biophysicist, N. Rashevsky:

"Following the fundamental method of physicomathematical sciences, we do not attempt a mathematical description

of a concrete cell, in all its complexity. We start with a study of highly idealized systems, which at first, may even not have any counterpart in real nature. This point must be particularly emphasized. The objection may be raised against such an approach, because such systems have no connection with reality and therefore any conclusions drawn about such idealized systems cannot be applied to real ones. Yet this is exactly what has been, and always is done in physics. The physicist goes on studying mathematically in detail, such nonreal things as 'material points,' 'absolutely rigid bodies,' 'ideal fluids,' and so on. There are no such things as those in nature. Yet the physicist not only studies them but applies his conclusions to real things. And behold! Such an application leads to practical results -- at least within certain limits. This is because within these limits the real things have common properties with the fictitious idealized ones! Only a superman could at once grasp mathematically all the complexity of a real thing. We ordinary mortals must be more modest and approach reality asymptotically, by gradual approximation."

This study will endeavor to bring forth additional understanding of biophysical characteristics of the periodontal ligament and will open the door for future research in this area.

B. STATEMENT OF THE PROBLEM

The purpose of this research was to study quantitatively the stresses that develop in the horizontal fibers of a periodontal ligament analogue. This was done with a synthetic substance having stress characteristics similar to the human periodontal ligament. The stress characteristics of this substance were tested using two-dimensional and three-dimensional analogues.

CHAPTER II

REVIEW OF THE LITERATURE

Biophysics is a specialized area in the field of applied physics. It pertains to specific systems which are composed of organic materials that are organized into cells. These cells are arranged into tissues and organs which are interrelated behavioristically, though they do not follow identical mathematical relationships. Biophysics applies to every biological function of the body, including orthodontics. Jarabak states that the entire body may be ultimately described by mathematical formulas.

Due to the complexity of the problem, the review of literature has been pursued with four definite ends in view:

- I. The biophysical approaches to the study of stresses, with special emphasis on the engineering aspect of stresses.
- II. The biophysics of stress in relation to orthodontic tooth movement.
- III. The biometrics of tooth movement.
- IV. The use of physical models and physical instrumentation to study the biophysics of tooth movement.

Hooke (1676) studied elastic properties of materials. He formulated the law used to define the elastic properties of a body. Studying tensile forces,

he observed that the increase in the length of a body is proportional to the applied force over a rather wide range of forces. He concluded that "stress is proportional to strain." This is known as Hooke's law.

Young (1806) studied the elasticity of heart muscle. He observed certain characteristics which led to the definition of the physical constant called "Young's Modulus."

Timoshenko (1914, 1934) defines elasticity as, "External forces producing deformation of a structure not exceeding a certain limit, the deformation disappears with the removal of the forces." His formulas deal with every aspect of elasticity in relationship to strain and stress using polar, rectangular, and curvilinear coordinates. He explains stress as follows:

Under the action of external forces on a body, internal forces will be produced between the parts of the body. The magnitudes of such internal forces are usually defined by their intensity, i.e., by the amount of force per unit area of the surface on which they act. In discussing internal forces this intensity is called 'stress.'

Timoshenko concludes that all forms of stress, strain, and elasticity can be derived mathematically.

Milch (1940), studying stresses on the femur, used a photoelastic method of observing deformation. The method consisted of building a transparent scale model of bone to observe stress patterns.

Evans (1948), using "Stresscoat", studied stresses. He concluded that this method can be used to "Pinpoint" the areas of greatest stress on surfaces of bones.

Carothers (1949), using engineering methods to study the elastic

properties of bone (femur), observed that bone follows the principles of Young's Modulus of Elasticity and Hooke's Law.

King and Lawton (1950), Studying the elasticity of body tissues, observed that soft tissues closely resemble natural and synthetic elastomers which are "rubber-like substances." The following are his conclusions:

1. Elastomers and some soft tissues show the same type of elastic behavior with respect to elastic modulus and stress-strain diagram.
2. Elastomers and some soft tissues show the same changes in x-ray diffraction patterns when they are stretched.
3. Thermal behavior is similar in tissues and other elastomers.

Rashevsky (1960) applied mathematical biophysics to cell physiology -- specifically to cell division. He observed that non-uniformities of the concentrations of the cell protoplasm may produce non-uniformities in expansion or contraction, thereby causing mechanical stresses. He also found that stresses may be due to external forces such as gravity, electric, or diffusion forces. He concludes that stresses in the cell must be computed from the existing external and internal stresses.

The next literature will deal with the biophysics of stress in relation to orthodontic tooth movement.

Angle (1907), considering the dento-alveolar periodontal environment from a physical point of view, noted that there are areas of tension and compression in the periodontal ligament. This led him to conclude that "pressure caused osteoclastic activity."

Case (1908,1921) studied the physical aspects of orthodontic tooth move-

ment. He described the action of tooth movements as "lever arms" and tested crude wood levers to observe their action.

Schwarz (1932), using biological material, studied the biophysical aspects of tooth movements. He concluded that a force of 20 to 25 gms. was adequate to move incisor teeth of dogs. He also observed that the magnitude of pressure decreased as the center of rotation was approached.

Synge (1932) describes stress as it is used in physics:

Elasticity deals with strain and stress. Strain consists of (1) change of size, (2) change shape. Stress refers to the forces exerted by adjacent parts of the body on one another. If we draw a plane in the body, we may think of the forces exerted by the particles lying on the other side. The stress is the force per unit area across the plane. The component of the stress in the plane is called the shearing stress; the component perpendicular to the plane is called the normal stress. It may be either a tension (pull) or a pressure (push).

From this definition, he formulated his theory of an "incompressible periodontal membrane."

Zak (1935), using the photoelastic method on a physical model, concluded that stress may be determined qualitatively on the alveolus and on the tooth. These stresses, he observed, varied with the location of the fulcrum for tipping, and were uniformly distributed for translation.

Renfroe (1951) believes that only a part of the root surface resists tooth movement at any one time. This part depends on the direction of the force. He further asserts that in a tooth having a round root, fifty percent of the periodontal ligament would be resisting the movement and fifty percent of the ligament would be relaxed when this tooth is being translated.

Storey and Smith (1932), investigating the effects of differential forces on canines and anchor units, found that force between 150 and 200 gms. tipped the canine; and forces of 300 to 500 gms. moved the anchor units. The canine teeth remained stationary, acting as anchor units when excessive forces were applied to them because these forces drove them against the alveolar wall. Storey and Smith concluded:

Undoubtedly it is not the force that is exerted on the tooth that is significant, but rather the pressure (i.e., force per unit area) which is exerted at the interfaces between tooth, periodontal membrane, and bone. It is this pressure and its distribution over the surface of the root that will be difficult to estimate for various appliances and this could limit their proper design.

Shroff (1953), investigating the physical aspect of the periodontal ligament, observed that forces of occlusion were transferred to the bone in two ways. One was through the stresses developed in the fibers of the periodontal ligament while the second was through the viscous elements of the periodontal ligament.

Burstone (1961) called attention to the need of understanding stress in the periodontal ligament. He stated:

"Perhaps the most important and least understood is the stress-strain level of activity in the periodontal membrane. If the stress (force per unit area) level could be accurately determined in different areas of the periodontal membrane, this may well offer the best opportunity for correlating force application on a tooth with tooth response."

Sicher (1962) points out the importance of proper terminology in describing tooth movements as a result of force application, in that tension and compression should be used rather than tension and pressure.

Jarabak and Fizzell (1963) describe the results of force application by stating the following:

"The word 'pressure' is not accurately used because there is a compressive stress on the pressure side of the root and a tensile stress on the opposite side. There are also shearing stresses around the edges."

Eldrect (1939), studying the elasticity of the periodontal ligament by means of a dial indicator, observed tooth movements when he pushed them with his fingers.

Werner (1942) used an oscillometer to measure elasticity of the periodontal ligament of a tooth. It consisted of a rod with a scale attached and held in front of the teeth.

Muhleman (1960) measured tooth mobility by the use of his macroperiodontometer. This instrument consisted of a dial indicator mounted on movable rods with locking nuts to an impression tray. The instrument was cemented to the posterior teeth. The teeth were deflected in a labio-palatal or palatolabial direction with a known force using a "force meter." He observed two phenomena. The first he called "initial mobility"; it was shown by a large rate of deflection under forces up to 100 gms. The second he called "secondary movement" in which the force-deflection curve formed a plateau or small rate of deflection when the forces ranged from 100 to 500 gms. The initial mobility, according to Muhleman, corresponds to an intra-alveolar displacement of the root associated with a preparation of the alveolar dental fibers on the tension side for functional action.

Rudd and O'Leary (1963) analyzed the force-deflection characteristics

of the periodontal ligament using a multijointed instrument to support a dial test indicator. Rudd and O'Leary concluded that their instrument obtained the same results as Muhleman, using a macroperiodontometer.

Literature pertaining to the use of physical models will not be cited.

Case (1908) was among the first to use physical models to study the influence of orthodontic forces. Using a stake driven into the ground to a depth of approximately two-thirds of its length, he pushed against the upper part of the stake. He observed that the tipping movement occurred about an axis somewhere near the middle of the buried portion.

Fish (1917) studied force application stimulating those produced with orthodontic appliances on mathematical models. He pointed out that a force, F , applied to the crown, could be resolved into an equal force F_2 , acting through the center of resistance, and by a $(F \times H)$, tending to tip the tooth:

The resulting motion of the tooth must be a combination of translation due to F_2 and rotation due to the couple $(F \times H)$; then the effect of the couple is to move the apex of the root in a direction opposite the applied force.

Schwarz (1928), using a match-stick placed into soft plaster, did a more refined experiment than that performed by Case, but drew the same conclusion as did Case. Schwarz then used wooden teeth suspended in an elastic material to study tooth movements when specific forces were applied to their crowns. He concluded that the fulcrum was located in the lower half of the root in single rooted teeth.

Bauer and Lang (1928), using mathematical models of teeth, formulated the following assumptions:

- I. That the root is cone-shaped.
- II. That the root is two-thirds the length of the tooth.
- III. That the force is applied at the extreme end of the crown perpendicular to the long axis of the tooth.

Their equation for the location of the center of rotation differed from that of Schwarz only in the labeling of the dimensions of their mathematical model.

Synge (1933) was asked to devise a theory on the physical aspects of the periodontal ligament in regards to the displacement of a tooth and the stress-strain in the ligament. He lists the assumptions needed for the study of the problem:

An elastic membrane fills the space between, and is attached to, two rigid bodies, the tooth and the socket, of which the former is subjected to assigned forces, while the latter is held fixed. We assign to the membrane the following properties:

- (i) infinitesimal, but not necessarily uniform, thickness;
- (ii) homogeneity;
- (iii) isotropy;
- (iv) incompressibility;
- (v) finite rigidity;

and we shall suppose that the free edge, or margin, of the membrane is subject to atmospheric pressure. The problem is to investigate the equilibrium of the system, particularly with regard to the displacement of the tooth and the strain and stress in the membrane.

Synge, using mathematical models, also concluded that the displacement of the tooth was very small and varied with the cube of thickness of the

membrane. Thereupon, he concluded that for a conical model with a membrane of uniform thickness, several other facts were significant:

- A. When a horizontal force was applied, the pressure was atmospheric at the margin, the apex, and at intermediate points near the axis or rotation and the apex, and between the axis and the gingival margin.
- B. When a vertical force was applied, the pressure lessened from a maximum at the apex to atmospheric pressure at the margin.
- C. At the gingival margin, the pressure in the membrane was always equal to atmospheric pressure.

Schwalb and Rechter (1950), employing the photo-elastic method of stress evaluation, constructed a two-dimensional transparent Bakelite model of a socket and an acrylic tooth model. A polariscope was used to view the model when various types of orthodontic forces were applied to the crown portion of the model tooth. Photographs were taken of the internal stresses set up in the Bakelite model. Schwalb and Rechter concluded that:

"The direct contact of tooth and bone socket surfaces thus permits externally applied forces to be measured by the strain patterns. The size and shape, color and location of the stress bands all serve to indicate the distribution of forces along the root bone junction."

Bein (1951) reasserts the engineering definition of a force as having magnitude, a direction, and a point of application. He states that all forces act in accord with Newton's Third Law, "For every action there is an opposite and equal reaction force." Using mathematical models, he concluded that direction of force is the most difficult to assess, because the tipping action of a tooth varies with the load applied to it.

Burstone (1962), states that a force influences the periodontal envi-

ronment at three levels: clinical, cellular, or as stress-strain. The most important and least understood is the stress-strain reaction on the periodontal ligament. Brustone goes on to state:

"Since at this time it is not possible to place strain gauges in the periodontal membrane to measure stress distributions, our knowledge of stress phenomena must depend on another approach. A mathematical model of the tooth and surrounding structures can be constructed based on certain assumptions. From these mathematical models theoretical stress levels can be calculated if the forces applied to the teeth are known."

Weinstein and Haack (1963), to illustrate the means by which the application of forces to the crown of a tooth initiates a distribution of stresses in the periodontal ligament, constructed a two-dimensional wooden model, of a maxillary central incisor which had elastic foam sponge in the space between the root and alveolar process. They stated that, "...it is the nature of this distribution which determines the pattern of bone resorption and apposition and, thus, the whole complex geometry of tooth movement." Weinstein and Haack were certain that it was of the utmost importance to an orthodontist to have a true comprehension of this occurrence and to be able to demonstrate it qualitatively. Concerning a quantitative solution to the problem, they felt that it was possible "only if rather severe simplifying assumptions are imposed" which often made their clinical application impractical.

Jarabak and Fizzel (1963) developed mathematical formulas to study distribution of stress in the periodontal ligament. They arrived at the formula for a tooth in translation as: "Stress is equal to the translating force over the projected root area or $S = F_m/A_r$. The stress is in force per unit area."

They next studied tipping. Using formulas derived for stresses in beams they established the formula that stress is equal to the magnitude of the tipping couple times the distance from centroid to the most remote apical fibers in the periodontal ligament, over the moment of inertia, or $S = \frac{Ma}{I}$. The formula for stress at the opposite end of the root is basically the same, only the distance is from the centroid to the most remote cervical fiber in the periodontal ligament.

In tooth movement, it is difficult to achieve pure tipping or translating. This led them to use the theory of "superpositioning" which states that "the simultaneous application of both a translating force and tipping couple causes an addition of the stresses." By combining the formulas in the following manner they were able to determine the stress distribution:

$$S = \frac{F_m}{A_r} + \frac{M_c g}{I} \quad (\text{for the marginal areas})$$

$$S = \frac{F_m}{A_r} - \frac{M_c a}{I} \quad (\text{for the apical areas})$$

By equating stress to zero in the above formulas, they were able to determine the axis of rotation of the tooth.

They concluded that, "...by the proper amount of neutralization of a tipping moment, one can place the center of tipping outside of the root. By complete neutralization of the tipping moment, one can place the center at infinity and obtain pure translation. Conversely, by employing a large tipping moment or couple, one can obtain tipping around the centroid."

Dempster and Duddles (1964) used an enlarged model of a mandibular molar

in its socket to study force characteristics applied to its crown. Force gauges were attached to the model tooth at the points of tooth-socket contact and forces perpendicular to the surface measured at these points. Free-body diagrams of each equilibrium situation included the magnitude and direction of each force and its point of application. For a given set of conditions (when the forces were in equilibrium), the gauges measured forces comparable to those involved in the statics of the tooth.

They concluded that forces acted as mean vectors and not as pressures, stresses or differentially distributed patterns of force. The vital properties of the living periodontum and the mechanisms of socket responsiveness and repair have also been set aside. Dempster and Duddles also concluded:

- A. Two static systems of force may be contracted. One, the action of a force couple on a crown, the other results from oblique or transverse forces on the crown. This system is used by orthodontists.
- B. The force vectors acting on the different parts of the roots attach them at specific angulations, at particular regions, and with varying magnitudes.
- C. The magnitude of one or two of the reaction forces on the roots at the apices or alveolar margins may be nearly as great as the applied coronal force.

Geigel (1965) used an enlarged three-dimensional analog of a mandibular left cuspid and its periodontal environment made of rubber webbing. This model was designed and constructed to study the orthodontic tooth movements occurring when various force systems are applied to the crown of the tooth. The force systems were a force, a couple, and a combination of force and couple, the latter produced pure translation.

The analog was anchored to a wooden platform to which dial indicators were attached to measure the movements at the apex (of the root) and cervix (alveolar crest area). Forces were applied to the crown of the analog at four points on the crown portion of the analog. Their points corresponded to three different levels of bracket placement in a clinical situation.

Geigel concluded that when single forces were applied to the crown, the center of tipping was between the centroid and the apex. Where the force magnitude increased and the point of application raised, the axis of tipping moved closer to centroid. In the application of couples of lesser magnitudes, the center of tipping was below centroid. As the magnitude of the couple increased, the center of tipping occurred at centroid.

CHAPTER III

METHODS and MATERIALS

This study is being done on an analogue, which corresponds to a single rooted tooth. Therefore, some material must be used in the analogue, which simulates an in vivo periodontal ligament. It was necessary to obtain a material for the "periodontal ligament" analogue that would assume the same stress-deflection characteristics as does the live periodontal ligament. Before such a material could be selected, it was necessary to obtain the characteristics of a living periodontal ligament. Only after this determination was completed, could a material showing similar characteristics be selected. Force deflection characteristics of the periodontal ligament in vivo, were obtained to gain some insight into the physical behavior of this ligament.

A lower right canine was selected for the following reasons: 1) It is the tooth which is most frequently moved distally by means of tipping or translation in orthodontic treatment. 2) It is a single rooted tooth which would lend itself to analysis better than a multirouted tooth. 3) It is a tooth for which an analogue can be constructed. 4) It is a tooth which is readily accessible for force deflection studies.

Patients selected for the intra-oral force-deflection studies fulfilled the following requirements: 1) They were between the ages of 11 and 14 years and had never undergone orthodontic treatment. This is an age level when most patients undergo orthodontic treatment and the periodontal space is generally uniform. 2) They were patients whose mandibular canine teeth showed inter-

proximal spacing on either the mesial or distal sides of the tooth.

B. Construction of biometric apparatus to study in vivo tooth movement.

Maxillary and mandibular impressions were taken in alginate and poured in plaster. The plaster models were trimmed and mounted in a Galetti articulator, with the aid of a wax bite. An autopolymerizing acrylic clutch was constructed to cover the occlusal and lingual surfaces of the mandibular cast. The clutch covered the teeth as far as the point of maximum convexity of the crowns, on the labial surface. (Figure 1) The clutch was then trimmed and an opening cut opposite the right mandibular canine. This hole was larger than the canine in order that this tooth might move freely. A clear plastic platform was attached to the occlusal portion of the clutch. This platform covered the six anterior teeth. The clutch was then seated on the mandibular model. A slurry of autopolymerizing acrylic resin was placed within the peripheral confines of the clutch. The teeth of the maxillary cast were pressed into the slurry, forming an impression. The facets in this impression were used to guide the maxillary teeth into the clutch. (Figure 2)

An acrylic crown was made to provide maximum coverage of the tooth to be moved. This was done to allow placing of forces on the tooth. To reinforce the crown and to provide a loop to use in pulling the tooth labially, a .040 inch diam. wire was embedded in the plastic. (Figure 3) A small dial indicator, reading in thousandths of an inch, was mounted on the platform of the clutch so that its measuring tip could rest on the acrylic crown of the canine. (Figure 4) To pull on the tooth, a force gauge was hooked to the wire loop.

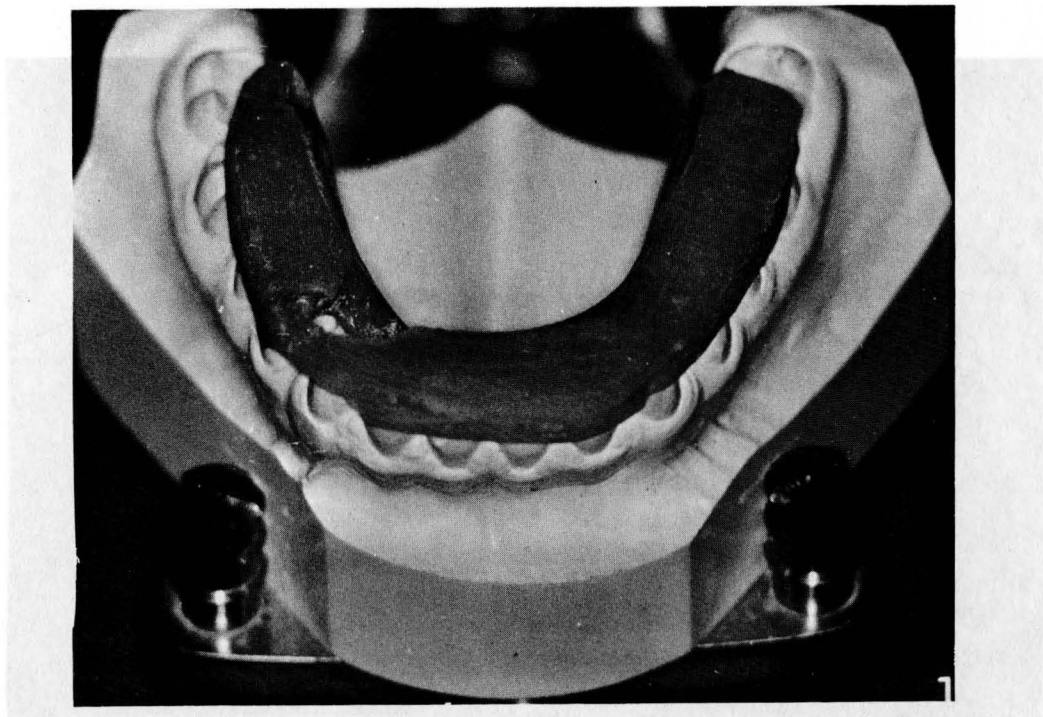

FIGURE 1

MANDIBULAR PORTION OF CLUTCH

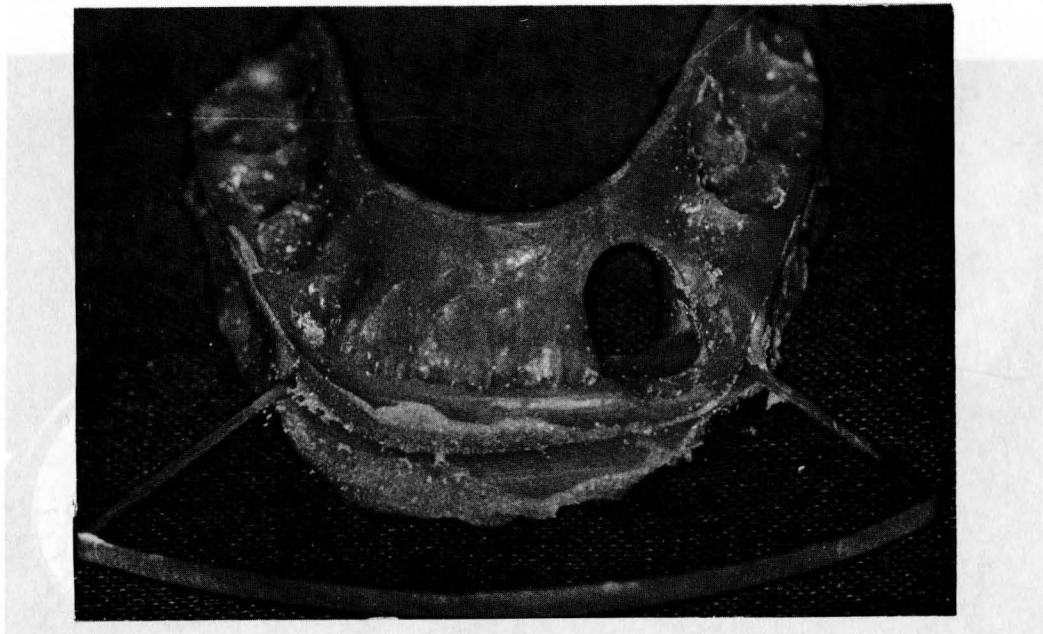
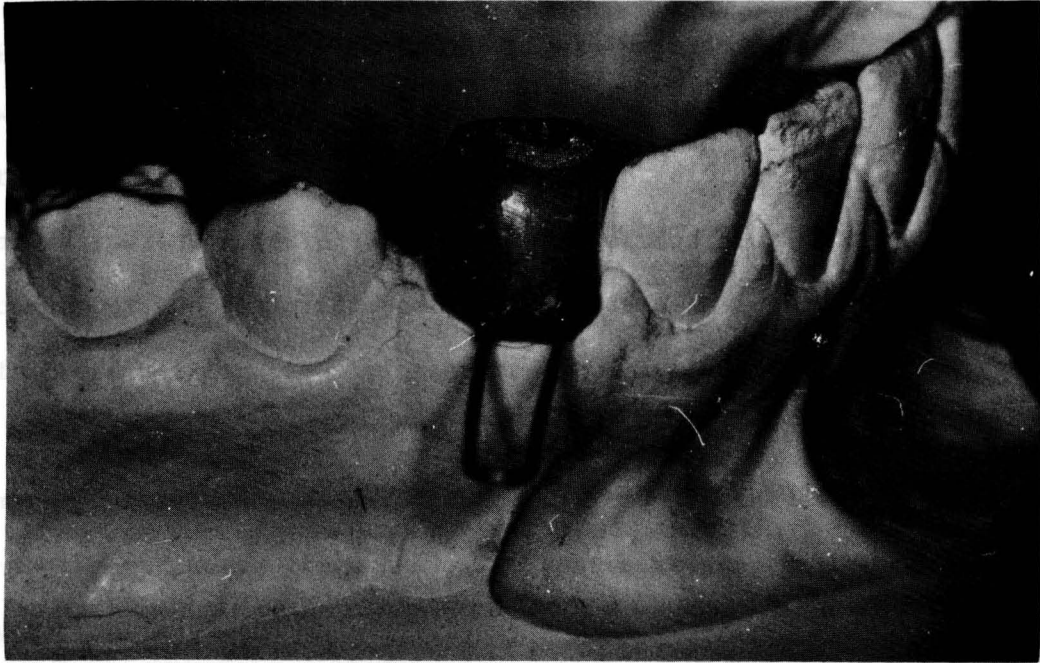

FIGURE 2

COMPLETED CLUTCH APPARATUS



The crown was attached to mandibular canine with zinc oxyphosphate cement and after COMPLETED CROWN ON TOOTH was cleared away to allow the tooth freedom of motion.

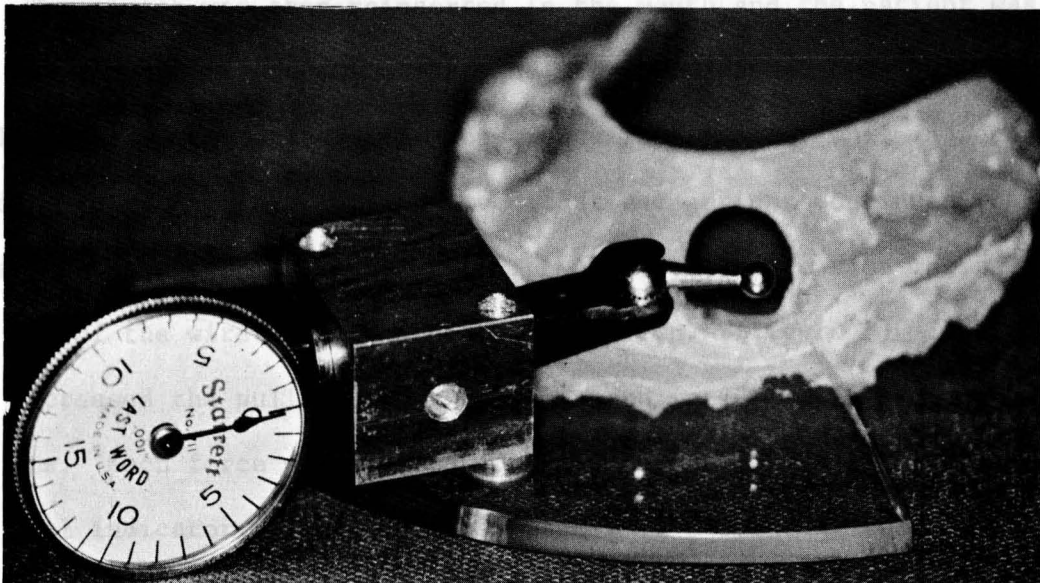

FIGURE 4

COMPLETED BIOMETRIC APPARATUS

To push on the tooth, the force gauge was pressed directly against the acrylic crown on the canine. Construction of the measuring device in this manner permitted accurate readings of the displacement of the tooth. The entire process of adjusting and aligning was done on an articulator to assure accuracy in the placement of the dial indicator and to reduce to a minimum the amount of discomfort and waiting time for the patient. (Figure 5)

The completed measuring device was seated in the mouth of the patient and examined for accuracy of fit, proper position of the dial indicator, and comfort to the patient. (Figure 6) The apparatus was then removed and any necessary corrections were made at once.

The crown was attached to the right mandibular canine with zinc oxyphosphate cement and after hardening, the excess cement was cleared away to allow the tooth freedom of motion.

The clutch was then reinserted in the mouth and the patient was instructed to close firmly on the clutch and not to release his bite. One operator applied the force to the wire loop with a force gauge, while a second operator read the dial indicator and observed that the patient continued to hold securely the clutch with his teeth. The point of application for pull was at the end of the wire loop attached to the crown. (Figure 7) The first operator increased the pulling force on the tooth in 20 gm. increments from 20 to 500 gms. Each force was applied for two seconds before a reading was taken on the dial indicator. (It should be noted that a force of 20 gms. was required to start the dial indicator moving.)

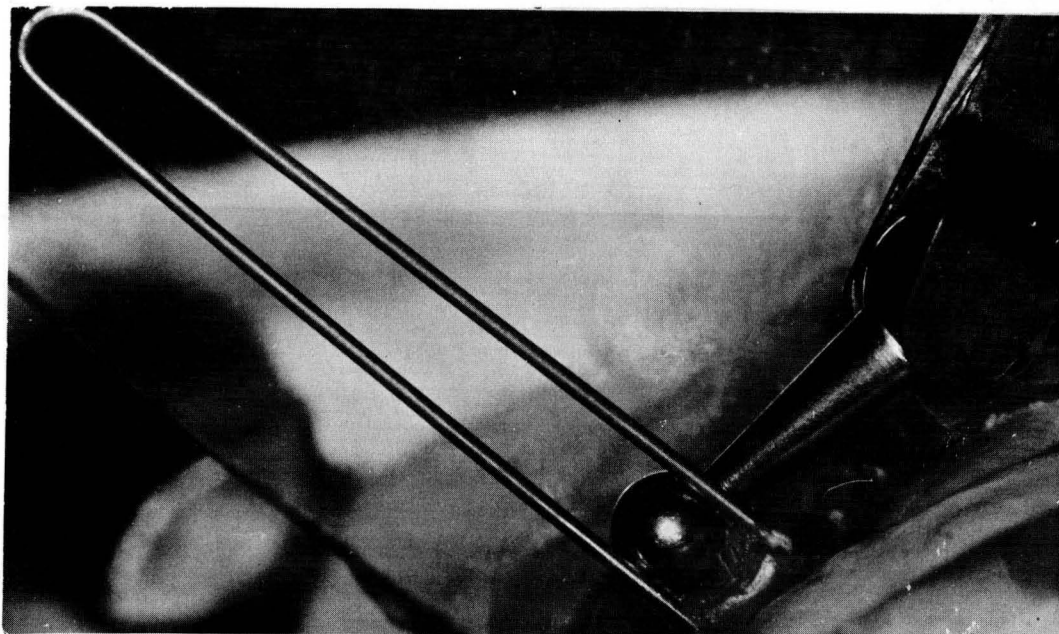
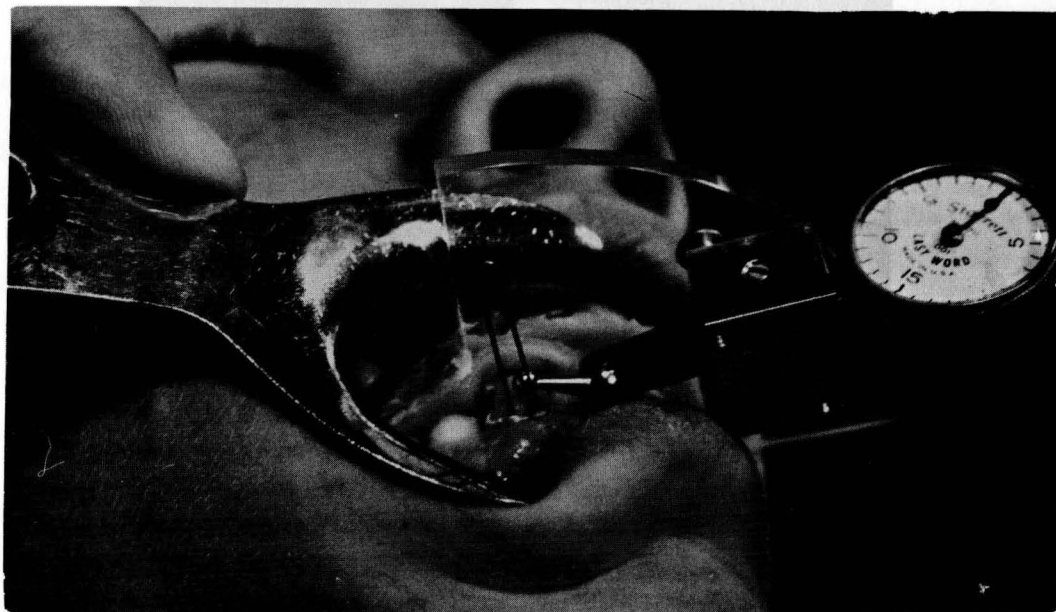

FIGURE 5

BIOMETRIC APPARATUS IN MOUTH



MEASURING IN MOUTH

FIGURE 6

POSITION OF SENSING ARM ON ARTICULATOR

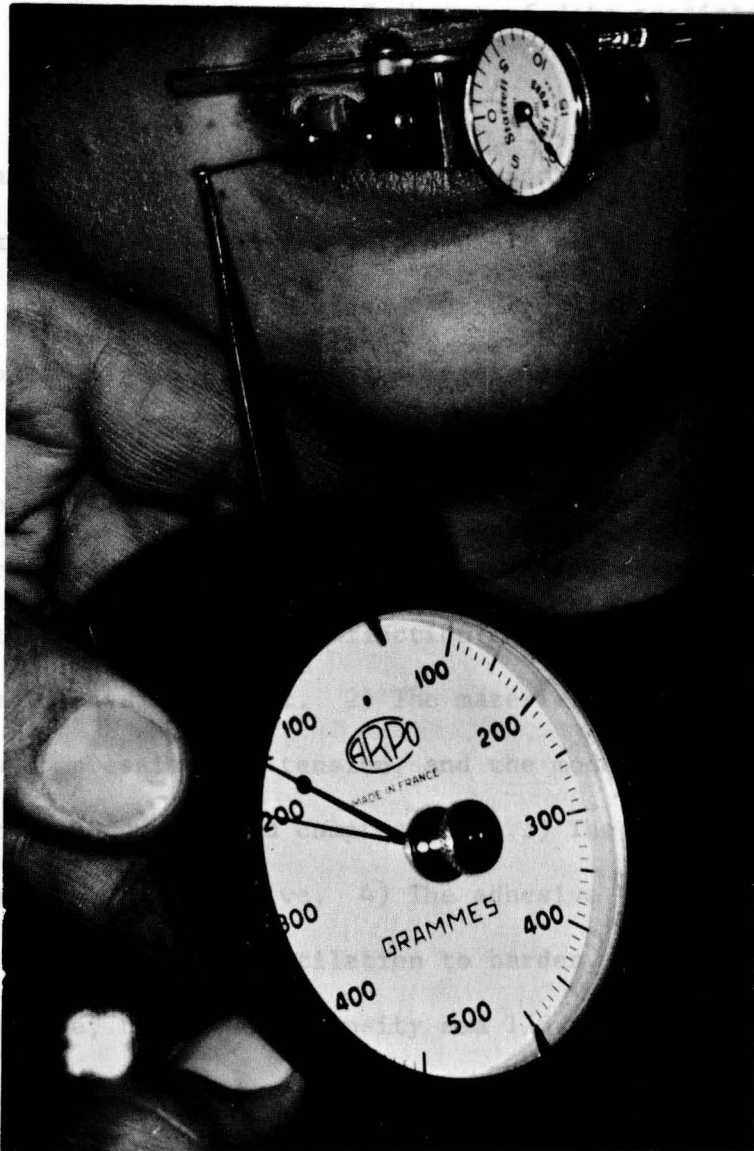

FIGURE 7

MEASURING IN MOUTH

When one set of data was collected, the patient was allowed to remove the clutch and rest. Two series of data were taken by pulling on the tooth, and two series of data were taken by pushing. The point of application for pushing was on the crown itself. Each set of data consisted of ten pairs of readings.

C. Material selection for synthetic periodontal ligament

The next part of the investigation dealt with the selection of a material for the analogue, having the same force response characteristics as the live periodontal ligament. Using the information gained from measuring the deflections of the tooth when known forces were applied to it, and anticipating the problem of cementing the material to the analogue, the following criteria were decided upon for the selection of a material: 1) The material had to be elastic with a force-deflection characteristic approximating that of a live periodontal ligament. 2) The material had to have linear characteristics in compression and tension, and the modulus of elasticity had to be the same for both tension and compression. 3) The material could not change upon application of an adhesive. 4) The adhesive had to be one which would not require either heat or ventilation to harden.

Polyurethane, three pound density and 1/8 inch thick, was chosen first and submitted to testing to satisfy the first material requirement. This material was discarded because its characteristics were non-linear and other foams and sponges were considered. Some were sponge rubber, Ensolite AH and H, Cellutite (soft and medium), Ethane, and Durafoam; there were thirty

different types of material tested before one was selected.

To satisfy the second requirement, the material had to have a linear characteristic. Sample specimens were cut at random from each material that was under consideration. Hubs were machined according to the following dimensions: (Figure 8) wire, .040 inch, was cut into various lengths and solder was applied at one end of the wire to make a ball. The wire was passed through the hubs and secured to them. The hubs were mounted on a special "testing machine" and the specimens were glued to hubs. A force of twenty grams was applied to the hubs and specimens, while the cement was allowed to dry for eight hours.

The specimens of elastic material were placed in the testing machine, and force was applied in such a manner that the specimens were subjected to one of the principal modes of stressing, i.e., compression, tension, or shear. (Figures 9, 10) The force was increased in 50 gm. increments. Deflection was read to the nearest .01 mm as each force increment was added. Each specimen was tested twice in the stresses but by different operators and then discarded. This procedure was repeated on three specimens. A correction factor was applied to the deflection readings to correct for the compliance of the force gauge. The corrected deflection for each type of stress was individually plotted on a force-deflection graph. Next, averages were taken of the deflection increments at each force level. These were graphed as "force versus deflection," to examine the linearity of each plot. It was found that a latex rubber foam, Durafoam (brand name), manufactured by U. S. Rubber Co., filled the designated requirements. Of all the materials tested in this

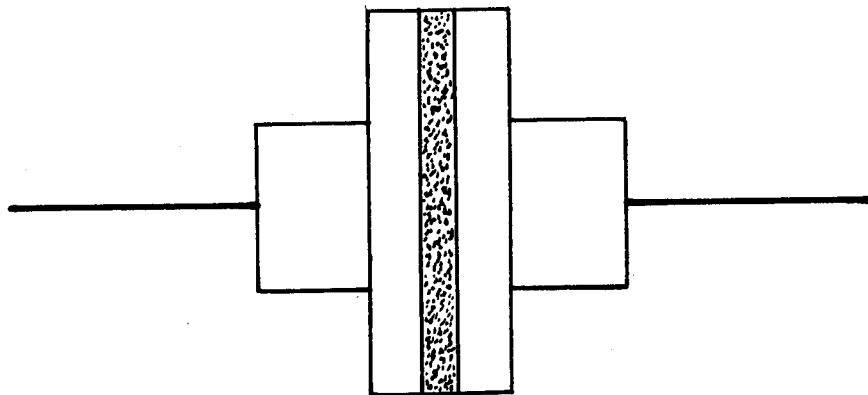
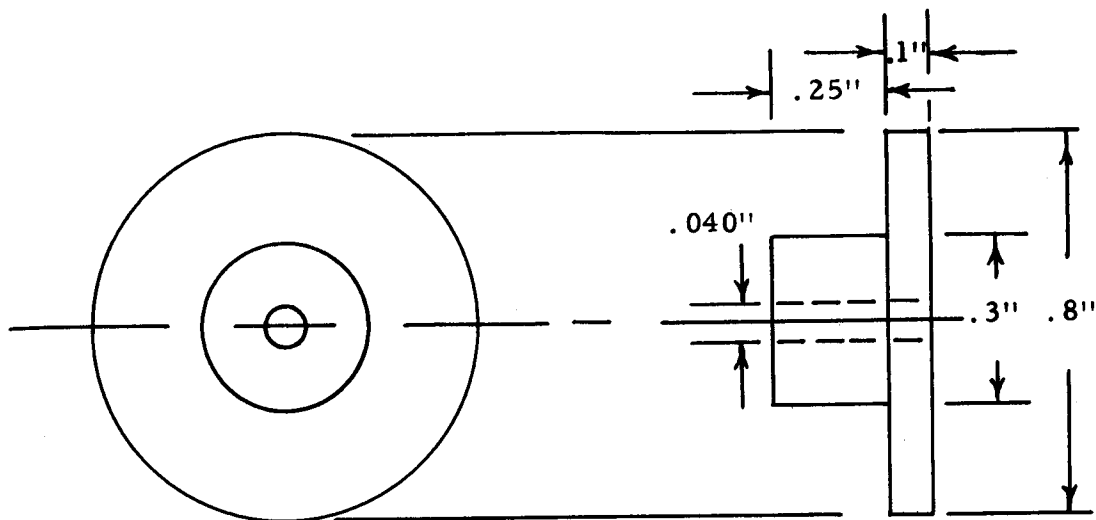

FIGURE 8

DIAGRAM -- MACHINED PLASTIC HUBS

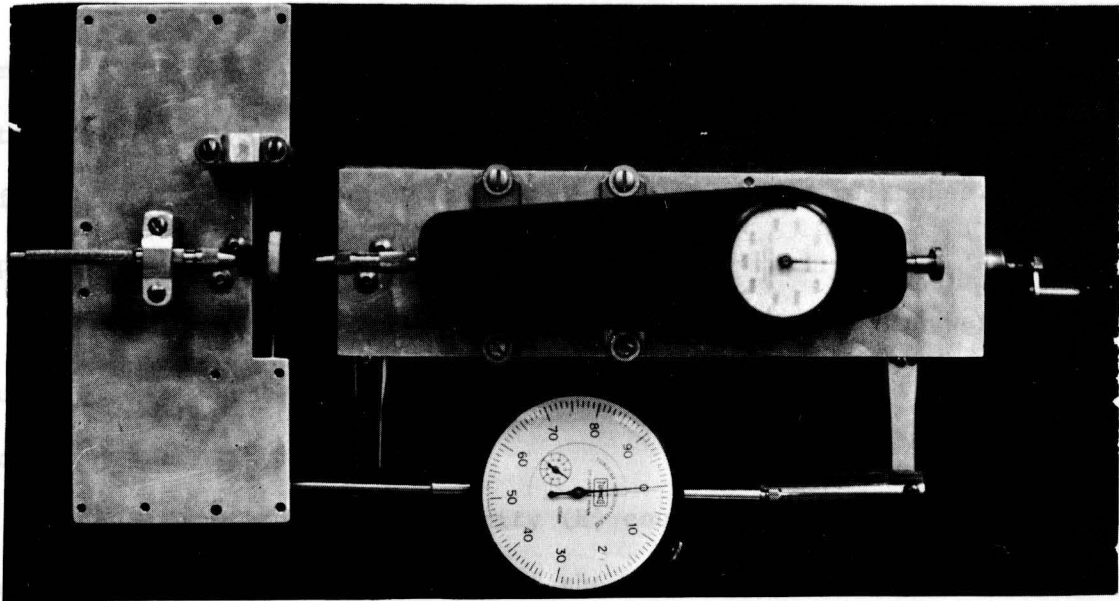

FIGURE 9

TESTING MACHINE WITH SPECIMEN MOUNTED FOR COMPRESSION TEST

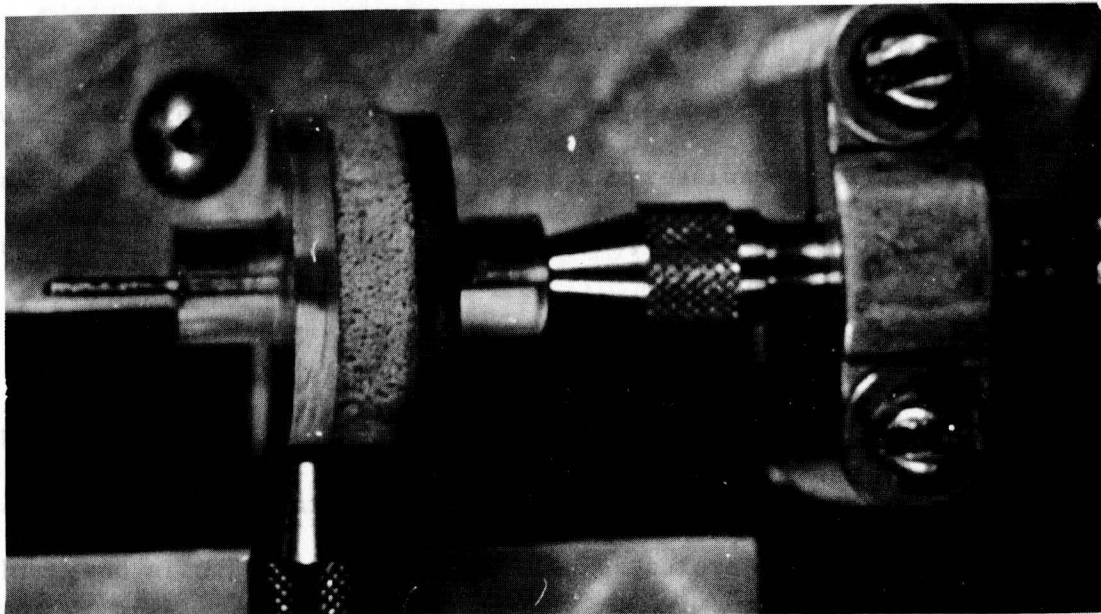

FIGURE 10

SPECIMEN BEING TESTED FOR SHEAR

manner, only 3/16 inch Durafoam was found to possess sufficient linear characteristics. This material had a linearity for all three stresses over a range from 0 gms. to 200 gms. on a sample area of 0.5 square inches. Beyond this point, the plots became non-linear.

Individual force-deflection readings of each test run were converted into unit stress and unit strain and graphed. (See Appendix I for conversion procedures.)

Young's modulus of elasticity (E) could then be found for Durafoam in compression by taking the ratio of the unit stress to unit strain. This was done by using the least squares formula $\Sigma X^2 / XY$. ΣX represents unit stress and XY represents unit stress times unit strain. This was done on each test run in compression.

The modulus of elasticity for tension was found using the same formula. Since E_t and E_c were so close, the modulus of elasticity of each individual run in compression and tension were averaged and the value of 14.972 p.s.i. was used as an average for E in both compression and tension. The shear modulus or modulus of rigidity (G) was found, using the same formula, to be 4.275 p.s.i.

Various adhesives were considered for the third and fourth requirements; they were Epoxy resins, Dupont Ducote, plastic cements, and Elmer's Glue. Each adhesive was uniformly applied to a piece of clear plastic 1/8 inch thick and allowed to set for two minutes before the specimen sample of Durafoam was placed on it. After the adhesive dried, the specimen was pulled off and examined to determine whether or not the Durafoam had been altered. It

was found that Epoxy resins and Elmer's Glue were the most satisfactory adhesives. Elmer's Glue was used instead of Epoxy resins because it hardened faster.

D. Analogues used for quantitative study of stresses.

Having selected a material which comes closest to the standards set, and having determined its moduli of elasticity and rigidity, the next step was the construction of analogues.

Two two-dimensional analogues were assembled on which the study could be carried out most expeditiously. Flexiglass, clear, preshrunk, and 3/4 inch thick was cut and milled in the shape of a rectangle to form the model tooth. The dimensions were approximately ten times the size of a normal mandibular canine. (Figure 11) Holes were drilled, threaded, and screws were inserted at measured distances at the top of the analogue. These screws were affixed to that portion of the analogue representing the crown of a tooth. (Figure 11)

A model alveolus was built by using two pieces of 3/4 inch clear plexiglass cut to the size of the model root. Separators were made from plastic rods, the center of which were drilled to accept through-bolts. The separators were cut so that when the "periodontal ligament" analogue (Durafoam) was used, it would be slightly compressed. (Figure 11) The alveolus was constructed by taking the two pieces of plexiglass and placing separators between them at the drilled holes. Bolts were passed through the holes and separators and were tightened with nuts. Another hole was drilled into the model alveolus in the center of the apical area in order that the sensing tip of the dial indicator could touch the analogue root. (Figure 11)

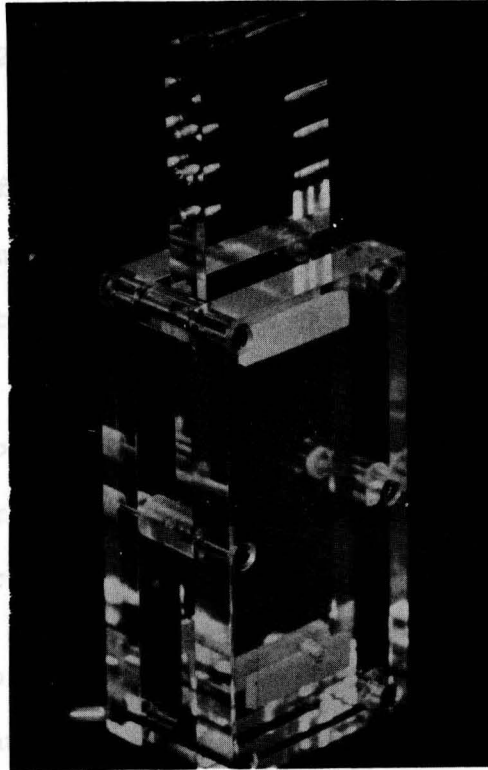

FIGURE 11

TWO-DIMENSIONAL MODEL

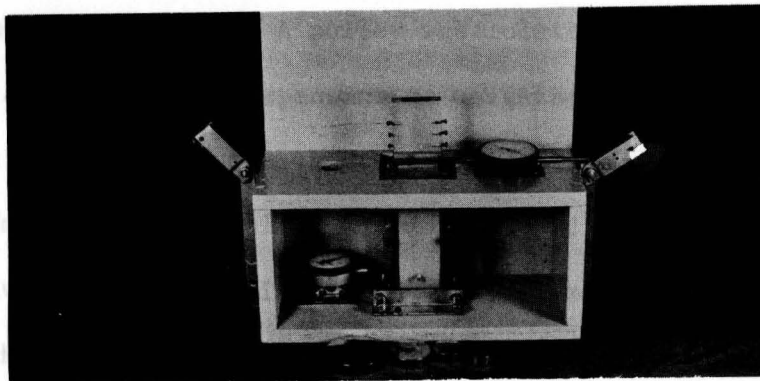

FIGURE 12

TWO-DIMENSIONAL MODEL SEATED IN MEASURING DEVICE

Model I had 1/2 x 2 inches wide strips of Durafoam placed in the upper and lower region of the model root, which would correspond to the horizontal and apical fibers of a tooth. Model II had a strip of Durafoam 2 x 7 inches which covered the entire root portion of the model, this corresponded to the periodontal ligament of a tooth. The Durafoam was first applied to the model root and allowed to dry. When all parts were fitted, glue was applied to the Durafoam, and the model alveolus was assembled. This joined the simulated periodontal ligament to both the model root and the model alveolus, and completed the construction of the analogue.

E. Mounting of two-dimensional analogue into a measuring device.

The completed analogue of the tooth, "periodontal ligament," and "alveolus" was mounted rigidly with bolts onto a plywood assembly. There were two platforms, one was the base and the other was at the level of the crest of the plastic alveolus. (Figure 12) Stability and rigidity to the entire apparatus was increased by fixing these platforms to the back of the plywood assembly with glue and long wooden screws. The entire assembly was reinforced with wood and steel braces. A pulley was located on each side of the upper platform to allow for the suspension of weights over the sides.

Two dial indicators were used to measure the movements of the model tooth in a "mesial-distal" plane (side to side direction). One indicator, reading in hundredths of a millimeter, was affixed on the upper platform contacting the side of the crown of the tooth. The other dial indicator, reading in thousandths of a millimeter, was mounted to the lower platform

and it contacted the tooth through a hole drilled in the plastic alveolus.

Three screws were inserted into the sides of the model tooth, in order to serve as posts for the attachment of the weights to the tooth. These screws were placed at different distances from the incisal edge. They were designated according to their position of the crown:

- (1) Top post (screw closest to the incisal edge).
- (2) Middle post.
- (3) Bottom post (screw furthest away from the incisal edge).

All essential dimensions of the entire assembly are recorded in a diagram. (Figure 13).

F. Compressive and tensile stresses.

In order to produce tipping of the model tooth within the limits of its alveolus, single forces of known magnitude and direction were applied to the crown. The point of force application was known in every instance, since the screws on the crown were used as the posts for the application of the forces. The position of these screws (relative to the total height of the tooth) had already been predetermined.

Orthodontic steel ligature wire (.012 inches) was attached to the posts. A sufficient length of wire was used to reach from the posts, over the pulley, and down the end of the platform to support a tray of weights. The first set of data was taken with the weights attached to the top post.

The direction of pull of the wire could be controlled, because the height of the pulley was adjustable. The direction of pull was perpendicular

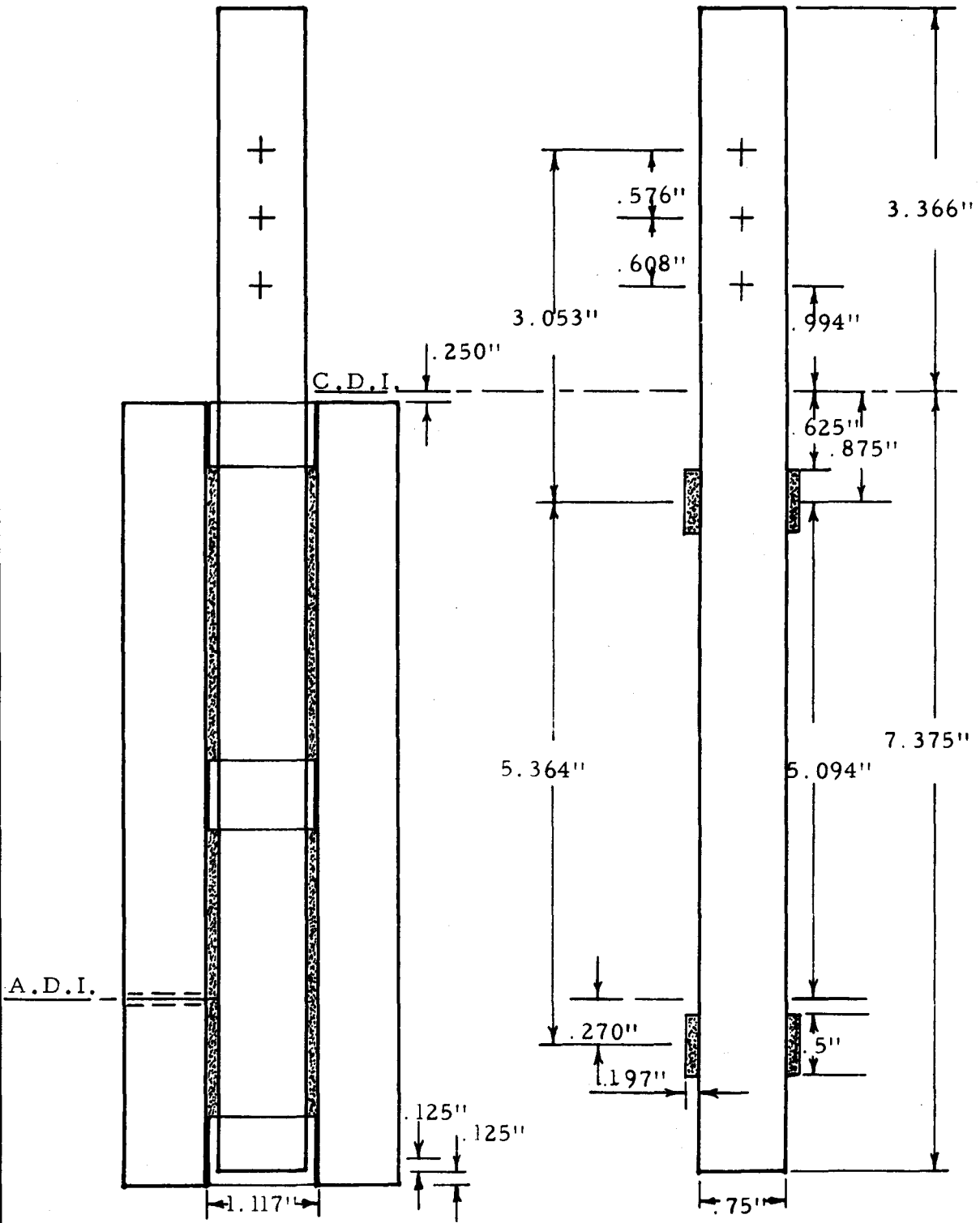

FIGURE 13

DIAGRAM -- TWO-DIMENSIONAL ANALOGUE

to the long axis of the tooth. The tooth and its alveolus were set upright in the platform assembly.

The weights used in this part of the research varied. Weights used on Model I ranged from 1/2 pound to 1½ pounds in varying increments. The weights used on Model II were .125 pounds, .250 pounds, .5 pounds, 1 pound, 1.5 pounds. These weights were applied one at a time to produce a force whose point of application was the top post on the crown of the tooth. The deflections of the crown and those of the root were measured by the upper and lower dial indicators, respectively, and recorded on the data sheet next to the weight that produced them. Readings of the deflections were taken after each of the weights had been allowed to act on the analogue for 2½ minutes. To test the accuracy of the data, the entire procedure was repeated three times; averages were taken of readings at each weight.

When all the data was obtained from forces applied to the top post, the wire yoke was changed to the middle post and the wire from the yoke to the tray was again made parallel to the platform by adjusting the height of the pulley. The procedure was repeated exactly as described for the top post and the experiment was repeated three times using the same weights and the same time intervals. Averages were taken and converted to inches.

As soon as the data had been recorded for the middle post, the procedure of changing the yoke and pulley was repeated and the experiment was run three times, as previously described.

The analogue was then removed from the measuring device, turned 90°, centered, placed back into the device, and anchored. The procedure for

collecting data was repeated with the analogue in this position so that the Durafoam was stressed in shear. Force was applied in much the same manner as described above with the following exception: The force was applied only on one side.

G. Force analysis for compression and tension.

Model I was used to determine the amount of resisting forces that occurred at the center of the Durafoam strip. This strip measured $1/2 \times 2$ inches. The summation of all the resisting forces that occurred along the entire strip of Durafoam was assumed to be at the center of the Durafoam.

To study quantitatively the amount of resisting forces present, it was necessary to find the deflection at the center of the foam in the cervical area of the root. The dial indicators were placed in such a manner that ratios and proportions had to be used to find the amount of deflection that occurred in the center of the Durafoam. (See Appendix II) Once the deflection at the center of Durafoam (A') had been determined, the next logical step was to determine the actual resisting force. This was done using Young's modulus of elasticity and the deflection (A'). (See Appendix III)

The equations of equilibrium were employed to determine the theoretical resisting force. In using this method of analysis it was possible to determine what the ideal resisting force should be. A free body diagram of the analogue was drawn and equations were written for the analysis of forces. (See Appendix IV)

H. Shear analysis.

The same procedure was followed to analyze the data obtained from Model I when the Durafoam was stressed in shear. The only exception was that the modulus of rigidity (G) was substituted for the modulus of elasticity (E) in Young's modulus formula.

I. Compressive and tensile stress analysis on Model II.

The data obtained from Model II were used to analyze stresses. A strip of Durafoam 2 x 7 inches was used. However, in this method of investigation, only the most remote cervical fibers from the centroid were analyzed. To examine these fibers, it became necessary to find the deflections of the Durafoam in the upper-most cervical area. The same procedure as used in Model I was employed here. The only change in the equations was "e", which became the distance from the C.D.I. to the closest fibers. (See Appendix V)

Once the deflection was found, the formula for the modulus of elasticity was once again used, but here, there were changes in its basic form. (See Appendix VI)

The method of determining theoretical stress used, was described by Jarabak and Fizzell in their textbook, Technique and Treatment with the light-wire Appliances. (See Appendix VII)

J. Shear analysis on Model II.

In evaluating the shear stressing on Model II, the same procedure was followed as was done for compression and tension. The modulus of rigidity was substituted for the modulus of elasticity.

K. Construction of a three-dimensional analogue model.

After completing the observations on the two-dimensional model, a three-dimensional model was constructed. This model represents, theoretically, a human canine. (See Figure 14 for dimensions.)

A large plastic rod was mounted on a lathe and one portion of it was turned to form a truncated cone. Holes were drilled radially in the crown portion and were used as points for application of forces. (Figure 14) This cone was to serve as the model tooth. The model alveolus was made from a block of clear plastic which had been bored out the same shape as the truncated cone, but $3/8$ of an inch larger in diameter. This allowance was made to represent the periodontal space.

Alignment holes were drilled into the sides of the model alveolus and then the model was sectioned along its vertical center line. Pins and washers were added to compensate for the material lost in cutting the model. It was possible to cement the Durafoam to one half of the model alveolus at a time, because the alveolus was divided.

Model III had $1/2$ inch band of Durafoam surrounding the cone portion in the cervical region and another band in the apical region.

The Durafoam was first cemented to the cone portion of the model. After the cement had dried, the cone portion was cemented to half of the alveolus. This was allowed to dry and then the other half of the alveolus was cemented to the cone portion. The alignment pins were inserted and the entire assembly was allowed to dry for twelve hours.

The assembled analogue was then anchored to the platform that had been

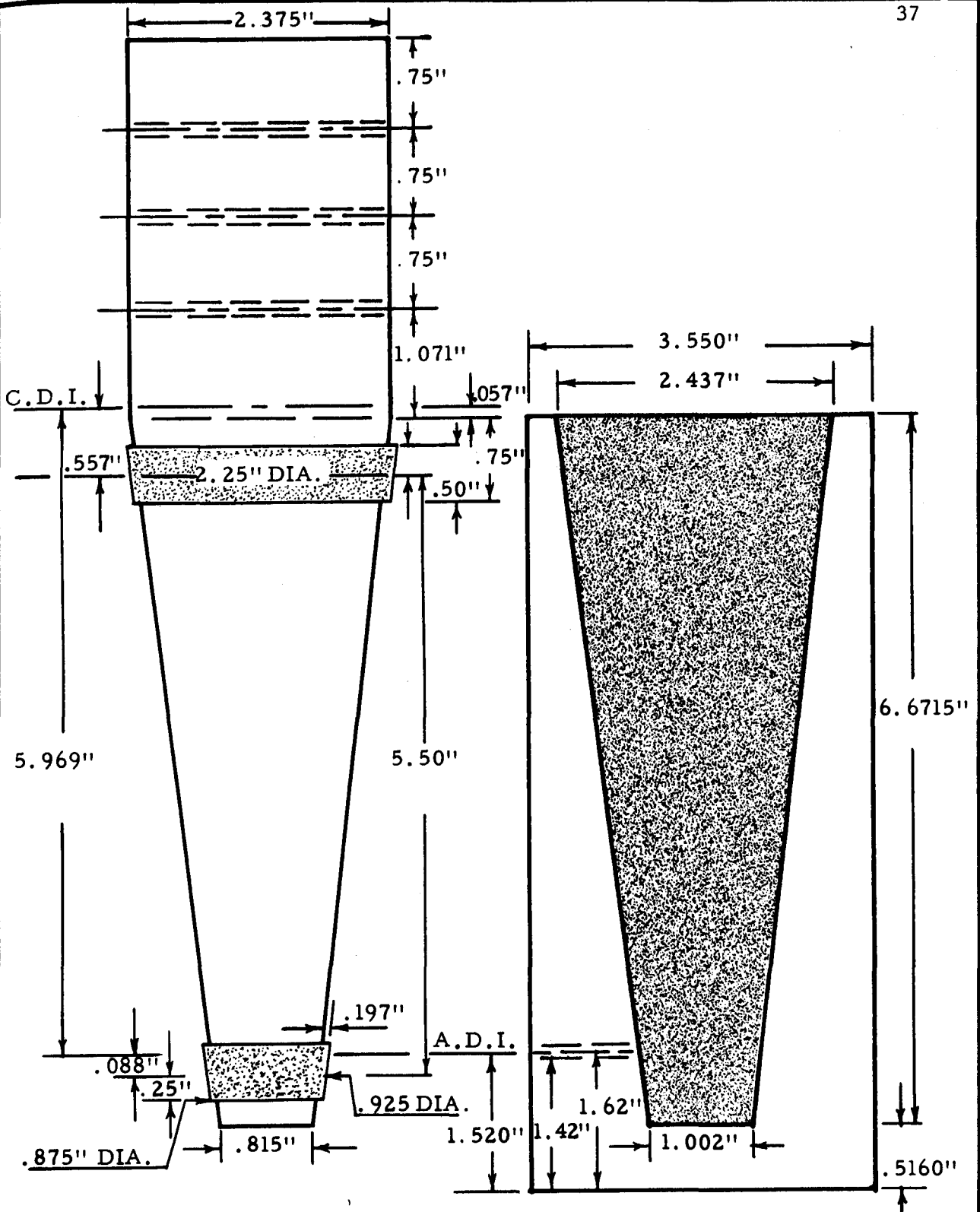

FIGURE 14

DIAGRAM -- THREE-DIMENSIONAL MODEL

used in studying the two-dimensional model. (Figure 15) The data were collected in the same manner as described earlier for the two-dimensional analogue.

The same approach was followed in finding the deflections of the Durafoam, as was previously done on the two-dimensional models. The means of analyzing the resisting force due to the Durafoam, was rather complicated because the resisting force comprised all three types of stresses in varying magnitudes. Young's formula was used and mathematical expressions were derived which would represent the amount that each type of stressing contributed to the resisting force. (See Appendix VIII) Integral calculus was used and the formula was solved by numerical integration on a calculator.

The theoretical resisting force was determined by using the equations of equilibrium as described in the analysis of Model I.

Model IV had a 6 inch band of Durafoam completely surrounding the truncated cone portion of the model. The Durafoam was attached to the model root and alveolus in the same manner as was done on Model III. The means of applying force to the analogue was exactly the same as those applied to the previous model. Model IV was analyzed for the center of tipping, stresses.

The center of tipping was found by using the method set forth in Appendix II. The theoretical center of tipping was found by using the projected root area theory as advanced by Jarabak and Fizzell. (Appendix IX)

The method of stress analysis for the three-dimensional model was the same as for the two-dimensional model. (Appendix IX) In the formula for

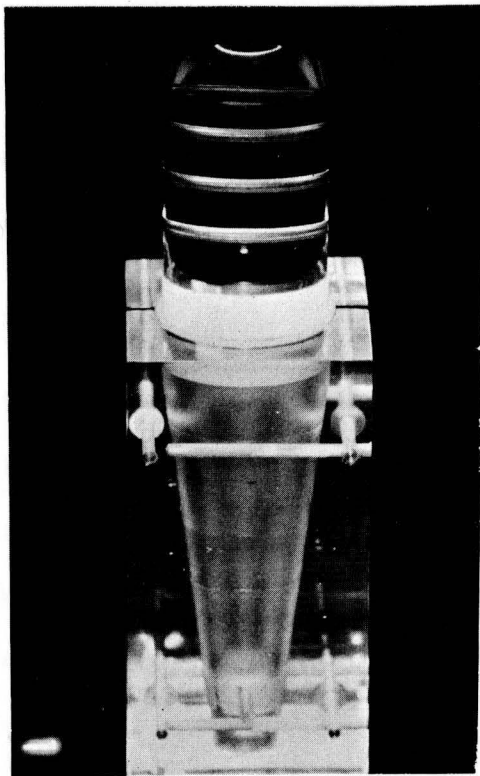

FIGURE 15

THREE-DIMENSIONAL MODEL

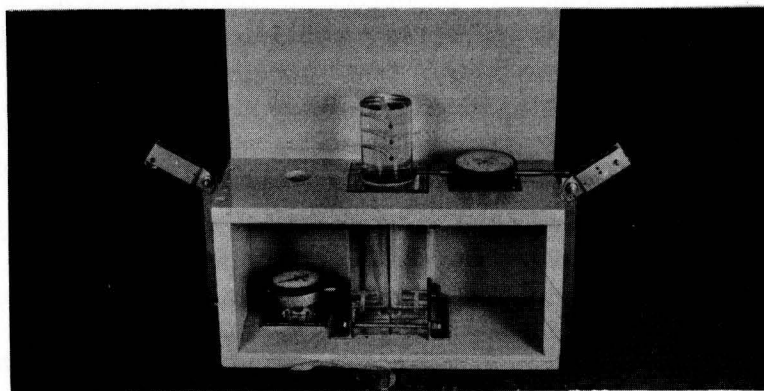

FIGURE 16

THREE-DIMENSIONAL MODEL
SEATED IN MEASURING DEVICE

theoretical stressing, $S_{max.}$, the surface area, centroid, and moment of inertia, was found for the projected root area which was the same as a trapezoid rather than the solid truncated cone. (See Appendix XI)

CHAPTER IV
EXPERIMENTAL RESULTS

A. An evaluation of the stress-deflection characteristics of six in vivo periodontal ligaments.

The first data that were gathered in this experiment related to the behavior of the live periodontal ligament under the influence of single forces of known magnitude acting on the crown. As previously described in the chapter pertaining to the construction of the biometric apparatus, the design was such that only a single force could act on the crown of the tooth at one time. The force could be in a pull-labial direction or a push-lingual direction. The deflections of the periodontal ligament were measured by the amount of movement the crown made when these single forces were applied to the crown.

The general observations of the movements of the periodontal ligament were that, as the magnitude of the force increased from 0 pounds to .441 pounds, the periodontal ligament was displaced proportionately. At force magnitudes of .441 pounds to 1.103 pounds, the periodontal ligament reacted differently. The amount of displacement of the ligament was noticeably less than it had been at the lower levels of force. The individual force deflection graphs for each patient are seen in the Appendix. (XII to XVIII) The graph of Figure 17 was prepared to illustrate the general changes that occurred when known force magnitudes were applied.

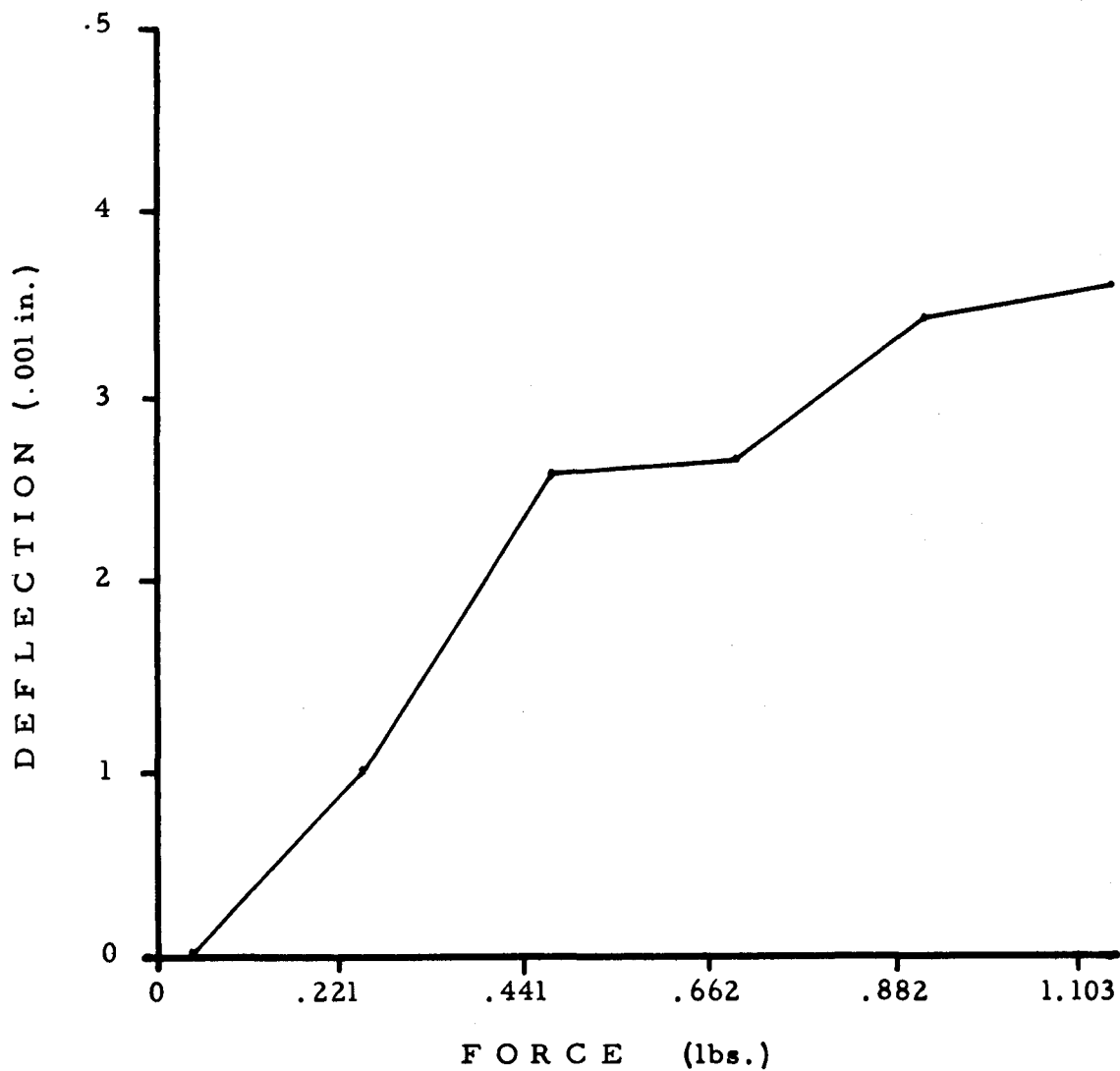

FIGURE 17

GENERAL TOOTH DEFLECTIONS THAT OCCURRED WHEN
KNOWN FORCE MAGNITUDES WERE APPLIED

B. Evaluation of material selected.

The Durafoam material was found to have linear characteristics. The force-deflection measurements were graphed to check the linearity of the material.

Fisher's Analysis of variance was used to further assess the reliability of tests on the Durafoam. This analysis separates the sources of variation and determines the amount of experimental error. Table I lists the main sources of variation and their interactions. The main sources of variation included three Samples, three Forces, three types of Stressing, and two Operators to perform the measurements. Non-significant three-factor and four-factor interactions were lumped together to determine the amount of experimental error. This was used to test some of the main effects and their interactions by means of the F test. The error variance was .000274, obtained from 16 degrees of freedom. The standard error was obtained by taking the square root of .000274, which was $\pm .016442$ mm. At the 99% confidence limits, the distribution of the experimental error was $\pm .04833$ mm. Since the original data were read on a dial indicator graduated in hundredths of a millimeter this means that any given observation might have an error as great as five divisions on the gauge. The standard error does not appear to be unreasonable since the great majority of the errors would be less than .02 mm.

The Forces x Stress interaction was found to be highly significant, due to differences in the force magnitudes under the three types of stressing. The main sources of variations were tested against the error variance. The

TABLE I

ANALYSIS OF VARIANCE
(DURAFOAM MEASUREMENTS)

SOURCES	D.F.	S.S.	M.S.	F.	SIGNIFICANCE
Samples	2	.09854	.049270	179.81	6.23 (1%) **
Forces	2	3.42718	1.713590	6253.97	6.23 (1%) ***
Stresses	2	4.92221	2.461107	8982.14	6.23 (1%) ***
Operators	1	.00466	.004667	17.03	8.68 (1%) *
S x F	4	.02049	.005123	18.69	4.77 (1%)
S x s	4	.10988	.027471	100.2	4.77 (1%) **
S x O	2	.00879	.004395	16.04	6.23 (1%)
F x s	4	1.66019	.415047	1514.62	4.77 (1%) ***
F x O	2	.00332	.001610	6.06	3.20 (5%)
s x O	2	.00230	.001152	4.20	3.20 (5%)
S x F x s	8	.02301	.002876	10.49	3.69 (1%)
s x F x O	4	.00090	.000226		N.S.
S x F x O	4	.00173	.000293		N.S.
S x O x s	4	.00422	.001053	3.82	3.01 (5%)
S x s x F x O	8	.00231	.000289		N.S.
TOTAL	53	10.28922			

D.F. = Degrees of Freedom

S.S. = SUMS of Squares

M.S. = Means of Squares

*** = Highly Significant Variance Ratio

N.S. = Non-significant Variance Ratio

Samples, Forces, and Stresses, were found to be highly significant. The mean square of remaining effect, Operators, was small and non-significant. This means that there was no discernible difference between the measurements taken by the two operators.

C. Evaluation of resisting forces produced by single forces on Model I.

The application of single forces of different magnitude, but constant direction to the crown of Model I, produced deflections that were characteristic of tipping. As previously described in Chapter III, relating to the method of analysis on Model I, the deflections recorded when tipping took place were used to calculate the resisting forces in the upper portion of the model in compression and tension and in shear. The resisting forces were determined mathematically according to the calculation shown in Appendix III. The data collected and evaluated in compression and tension is shown in Table II; the data collected and evaluated in shear are shown in Table III. As the force magnitude increased the resisting forces increased. (Tables II and III) When these same forces were again applied to the tooth, but at a different level of the crown, the resisting forces decreased. (Table II)

As a means of determining theoretical forces, the equations of equilibrium were used to find these forces as described in Appendix IV. The actual and theoretical resisting forces were compared at several values of applied force. The agreement was shown in Tables II and III.

The location of the center of tipping was calculated for each applied force and point of application by following the same mathematical procedure

TABLE II

MEASUREMENT IN COMPRESSION AND TENSION FOR RESISTING FORCES

MODEL I

TOP POST

Force in pounds	Center of Tipping	Actual resisting force	Theoretical resisting force
.0	.0	.0	.0
.5	1.374	.788 pounds	.784 pounds
1.0	1.138	1.603	1.569
1.5	1.113	2.353	2.353

MIDDLE POST

.0	.0	.0	.0
.5	1.225	.834	.738
1.0	1.007	1.579	1.461
1.5	1.018	2.189	2.192

BOTTOM POST

.0	.0	.0	.0
.5	.835	.659	.674
1.0	.876	1.267	1.340
1.5	.846	2.019	2.022

TABLE III

MEASUREMENT IN SHEAR FOR RESISTING FORCES

MODEL I

TOP POST

Force in pounds	Center of Tipping	Actual resisting force	Theoretical resisting force
.0	.0	.0	.0
.5	1.063	.808 pounds	.785 pounds
1.0	1.011	1.723	1.569
1.5	1.064	2.361	2.354

MIDDLE POST

.0	.0	.0	.0
.5	1.091	.712	.730
1.0	1.090	1.423	1.462
1.5	.960	2.742	2.192

BOTTOM POST

.0	.0	.0	.0
.5	.851	.683	.674
1.0	.770	1.338	1.348
1.5	.831	1.967	2.022

described earlier. The effects that the increase in force magnitude and change in the point of application had on the center of tipping were shown in Tables II and III. The centers of tipping were always more cervical when the forces were applied to the top post, and closer to the apex when they were applied to the bottom post.

D. Evaluation of stresses when a single force was applied to Model II.

Model II was submitted to the same systems of forces as Model I, to produce a tipping, and the deflections were recorded in the same manner. As has been described in Chapter III, the deflections were used to determine the maximum stresses that developed in the most cervical portion of the Durafoam. The stresses were first determined in compression and tension; then the stresses were determined for shear. The stresses were shown to increase as the force magnitude increased, this is seen in Tables IV and V. When these same forces were again applied to the model, but at different levels, the stresses decreased as shown in Tables IV and V.

To verify the accuracy of the theoretical stress determinations, the actual stresses were found and compared to the calculated theoretical stresses. The actual and theoretical stresses at the various posts and force magnitudes were compared. The agreement between the two ways of determining the stresses is shown in Tables IV and V. The location of the center of tipping was also found following the procedure described earlier. The changes that followed the increase in force magnitude and point of application had on the model are shown in Tables IV and V. The centers of tipping

TABLE IV

MEASUREMENT IN COMPRESSION AND TENSION FOR STRESS DETERMINATION

MODEL II

<u>TOP POST</u>			
Force in pounds	Center of Tipping	Actual stress	Theoretical stress
.0	.0	.0	.0
.5	1.424	.127 p.s.i.	.115 p.s.i.
1.0	1.306	.227	.217
2.0	1.428	.421	.434
3.0	1.519	.658	.651
<u>MIDDLE POST</u>			
.0	.0	.0	.0
.5	1.297	.099	.097
1.0	1.325	.194	.200
2.0	1.382	.406	.398
3.0	1.489	.610	.599
3.5	1.461	.705	.693
<u>BOTTOM POST</u>			
.0	.0	.0	.0
.5	1.513	.084	.090
1.0	1.245	.184	.181
2.0	1.258	.376	.362
3.0	1.272	.518	.542
4.0	1.295	.740	.724

TABLE V

MEASUREMENT IN SHEAR FOR RESISTING FORCES

MODEL II

TOP POST

Force in pounds	Center of Tipping	Actual stress	Theoretical stress
.0	.0	.0	.0
1.0	1.448	.211 p.s.i.	.217 p.s.i.
2.0	1.439	.430	.434
3.0	1.420	.682	.651
4.0	1.442	.858	.869

MIDDLE POST

.0	.0	.0	.0
1.0	1.324	.195	.200
2.0	1.385	.406	.398
3.0	1.398	.569	.599
4.0	1.369	.790	.798

BOTTOM POST

.0	.0	.0	.0
1.0	1.260	.192	.181
2.0	1.278	.372	.362
3.0	1.317	.525	.542
4.0	1.246	.720	.724

were always more cervical when forces were applied to the top post and moved down as the point of application of the force moved down.

E. Evaluation of Model III for resisting forces when single forces were applied.

Tipping was achieved on this model using the same force systems that were used on Models I and II. Appendix VII describes the mathematical computations for determining resisting force. Table VI shows that as the force magnitudes increased the resisting forces increased. When these same forces were again applied to the model, but at different positions on the crown, the resisting forces decreased. The theoretical resisting forces were found using the method described in Appendix VIII. The actual and theoretical resisting forces were compared at various force magnitudes. The agreement between the two methods is shown in Table VI.

The location of the centers of tipping was calculated for each force and at each point of application using the previously described procedure. It was found that 77.7% of the resisting force was due to compression and tension, and 22.3% of the resisting force was due to the shearing component.

F. Evaluation of Model IV for stress when single forces were applied.

This model was submitted to the same force systems as the previous models. As described earlier, in Chapter III, this model was used to find the maximum stress in the most cervical portion of the Durafoam. Once again, two completely different methods of determining the stresses were used. (See Appendix IX and XI) The agreement between the two methods is shown in Table VII.

TABLE VI

MEASUREMENT OF RESISTING FORCE

MODEL III

TOP POST

Force in pounds	Center of Tipping	Actual force	Theoretical force
.0	.0	.0	.0
.25	2.267	.427 pounds	.392 pounds
.50	2.261	.868	.784
.75	2.368	1.014	1.117
1.00	2.173	1.611	1.569
1.25	2.306	2.017	1.961
1.50	2.303	2.553	2.353

MIDDLE POST

.0	.0	.0	.0
.25	2.111	.393	.358
.50	2.099	.741	.716
.75	2.284	.924	.074
1.00	2.096	1.528	1.432
1.25	2.121	2.041	1.790
1.50	2.118	2.447	2.149

BOTTOM POST

.0	.0	.0	.0
.25	1.790	.380	.324
.50	1.689	.579	.648
.75	1.843	.790	.972
1.00	1.671	1.297	1.296
1.25	1.663	1.838	1.620
1.50	1.762	2.296	1.944

TABLE VII

MEASUREMENT OF STRESS

MODEL IV

TOP POST

Force in pounds	Center of Tipping	Actual stress	Theoretical force
.0	.0	.0	.0
1.0	2.580	.677 p.s.i.	.553 p.s.i.
2.0	2.074	1.377	1.107
3.0	2.566	1.670	1.660
4.0	2.771	2.061	2.214
5.0	2.806	2.500	2.767
6.0	2.777	3.322	3.318
7.0	2.823	4.120	3.871

MIDDLE POST

.0	.0	.0	.0
1.0	2.496	.451	.488
2.0	2.463	.956	.976
3.0	2.499	1.346	1.465
4.0	2.394	2.015	1.943
5.0	2.702	2.504	2.441
6.0	2.543	3.132	2.928
7.0	2.574	3.642	3.418

BOTTOM POST

.0	.0	.0	.0
1.0	2.182	.364	.423
2.0	2.481	.711	.846
3.0	2.326	1.208	1.269
4.0	2.274	1.810	1.693
5.0	2.239	2.354	2.116
6.0	2.434	2.623	2.538
7.0	2.509	2.976	2.961

In finding the center of tipping, the principles of plane geometry and the theoretical center of tipping, by Jarabak and Fizzell, were used. (See Appendix II and XI) At greater force magnitudes the agreement was very close.

CHAPTER V
DISCUSSION

Orthodontics is in a metamorphosis between an art and a science. This is the result of the knowledge gained from biophysics and bioengineering being applied to the process of moving teeth. By applying the principles of engineering and principles of physics to biologic media, orthodontics loses its empiricism. Applying these principles to understanding the cementum, periodontal ligament, and alveolar process, when known forces are applied to the crown of a tooth, gives the orthodontist greater insight into the biophysical aspects of tooth movement.

The basis for this research was the biophysical concepts of Jarabak and Fizzell (1963), and their theories on projected root area. To apply the principles of engineering mechanics to a problem, it is well to follow a logical outline as listed by Crandall and Dahl.¹ "1. Select system of interest. 2. Postulate characteristics of this system. This usually involves idealization and simplification of the real situation. 3. Apply principles of mechanics to the idealized model. Deduce the consequences. 4. Compare these predictions with the behavior of the actual system. This usually involves recourse to tests and experiments."

Applying the above rules to orthodontics would mean: 1. Tooth movements.

¹Crandall and Dahl, "An Introduction to the Mechanics of Solids," p. 1, McGraw-Hill Book Company, Inc., New York, 1950.

2. Postulate the theory of the projected root area and plan to test it on idealized models or analogues. 3. Apply the equations of equilibrium to the idealized tooth analogue and test equations for stress in the periodontal ligament analogue. 4. Construct suitable analogues, using a material simulating the periodontal ligament and determine the actual resisting forces and stresses, to test the theory of projected root area.

The first three parts of the general procedure were followed by Jarabak and Fizzell. The fourth part of the procedure was the purpose of this study. More specifically, this research deals with an appraisal of the reaction forces and stresses that develop in the periodontal ligament which resist tooth movements. These experimental results were compared with those obtained using theoretical formulas. With favorable comparison, it could be assumed that these formulas could be applied to the equivalent forces and stresses that develop in vivo.

The experimental results will be discussed as follows:

- A. The force-deflection characteristics of an in vivo periodontal ligament obtained from six patients.
- B. Assessment of resisting forces in the HORIZONTAL FIBERS on a two-dimensional model.
- C. Assessment of stress in the HORIZONTAL FIBERS on a two-dimensional model.
- D. Assessment of resisting forces in the HORIZONTAL FIBERS on a three-dimensional model.
- E. Assessment of stress in the HORIZONTAL FIBERS on a three-dimensional model.
- F. Appraisal of theoretical determination of the center of tipping.

G. The amount of compressive, tensile, and shear stresses that develop and the significance of each one.

A. The force-deflection characteristics of an in vivo periodontal ligament obtained from six patients.

Orthodontist routinely move teeth by stressing the periodontal ligament. Yet, little is known about the distance a human tooth will move immediately when a single force is applied to its crown. To study this problem, an apparatus was constructed, which would make it possible to apply a single force acting on the crown of a tooth in a definite direction for a short time.

The results shown in Figure 17, reveal the general movements of the crown of a tooth, subjected to this single force. These findings agree with those of Muhleman (1960) in demonstrating two slopes in the force-deflection curve. Most of Muhleman's work was done on older patients whose graphs showed the reduction in rate of deflection at about 100 gms. This research dealt with younger patients exhibiting greater elasticity in the periodontal ligament and their graphs showed the reduction in rate deflection at about 180 gms.

Muhleman (1960) felt that the higher rate of deflection resulted from an initial mobility in which the fibers of the periodontal ligament on the tension side were preparing for action. This is not in accord with the behavior of elastic materials because they deflect while assuming their load and become inactive after assuming their load. The existence of two rates of deflection suggests two mechanisms allowing deflection or at least a distinct change in the resisting mechanism. It was noticed when testing

synthetic materials for use in the periodontal ligament analogue that the material chosen had one rate of deflection in compression up to a stress of .882 p.s.i., and a different rate at higher stresses. Investigating the reasons for this change was not within the scope of this research.

B. Assessment of resisting forces in the HORIZONTAL FIBERS on a two-dimensional model.

A single horizontal force is rarely applied to a tooth because it is impossible to eliminate all of the other external forces that act on the tooth. It is possible to construct an orthodontic appliance which can deliver mainly a horizontal force, but this force will generally have vertical and transverse components. In addition to these components, there are other factors which make the problem even more complex. These are the forces of occlusion and those of the tongue and perioral muscles. Knowing that these forces exist and realizing the complex mathematical formulas which would have to be developed to include all of them, it was necessary to reduce the complexity of this problem by applying one force at a time to the crown of the tooth model.

The data that were collected in this part of the experiment were shown in Tables II and III. The tables show that in compression and tension, the deflection of the upper portion of simulated periodontal ligament increased as the magnitude of force increased. The rate of increase in the deflection was essentially constant. When a given force was applied to the lower posts on the crown of the model and then moved to the center posts and finally to

the upper posts, the amount of motion of the crown increased the the center of tipping moved up closer to the centroid of the root of the model. In a practical situation, this type of change in the point of application of force is accomplished by placing the orthodontic band closer to the incisal edge of the tooth. When a tooth is tipped all possible types of stress are simultaneously applied to parts of the periodontal ligament. In this model it was planned that the shearing stresses be studied independently from the other stresses. This study showed that the response of the tooth analogue was comparable to its response when the periodontal ligament was stressed in compression and tension but there was a much higher rate of deflection.

When the resisting forces were calculated from the corresponding deflections, they increased as the deflections increased. The explanation of this occurrence becomes obvious when one analyzes the movements of this model. When a single force, acting perpendicular to the long axis of the tooth, is applied to the crown, a moment of force is produced which equals the product of force magnitude multiplied by the length moment arm. By changing the location of the point of application, the length of the moment arm was changed and the deflection and resisting forces changed accordingly.

There remains now the consideration of resisting force proportions. The equations of equilibrium state that the resisting force in the horizontal fibers should be the sum of the activating force and the resisting force in the apical fibers. Dempster and Duddles (1964) stated: "The magnitude of one of the reaction forces on the roots at the apexes or alveolar margins may be nearly as great as the applied coronal force." Such an ambiguous

statement is hard to refute. This research found the equations of equilibrium to be accurate in showing the proportions of the resisting forces.

$$F_h = F_m \left(\frac{g+h}{h} \right)$$

$$F_a = F_m \frac{g}{h}$$

or

$$\frac{F_h}{F_a} = 1 + \frac{h}{g}$$

C. Assessment of stress in the HORIZONTAL FIBERS on a two-dimensional model.

When a force is applied to the crown of a tooth physical reactions occur in the periodontal ligament which are described as stresses. Many investigators believe these stresses are the stimulating factors for resorption and apposition of bone investigators have studied stresses on mathematical models. But, no one, until now, has attempted to determine quantitatively the amount of stress that develops when a force was applied to an analogue of a tooth. The importance of determining the amount of stresses in the live periodontal ligament that develop, becomes obvious when one realizes that with this information an orthodontist would be able to move teeth most expeditiously, with a minimal amount of damage to the alveolar-periodontal environment.

This two-dimensional model was submitted to the same force systems as was Model I. Stresses were calculated for only the most cervical fibers. The theoretical stresses were calculated using the theory of projected root area suggested by Jarabak and Fizzell (1963). Actual stresses were calculated

from the moduli of rigidity and elasticity and measured deflections. Agreement between the two differing methods was so close that the projected root area theory appears to offer a way to estimate extreme stresses in the periodontal ligament.

In evaluating the gross movements of this model, it became apparent that the tooth tipped around a center somewhere below its centroid. For this to occur, two phenomena were taking place at the same time. One was that the tooth analogue was tipping and the other was that it was translating. To explain this, one has to imagine that even though there is only one external force acting on the model, this can be resolved into a force and a tipping couple, as was explained by Fish (1917). The stress produced by the applied force, considered as a translating force applied at centroid, is the force magnitude divided by the projected root area. An unseen resisting force acts at centroid in an equal but opposite direction to the real force on the crown, thereby, producing a couple. This couple will tend to cause tipping around the centroid of the root. The combination of the translating force and the tipping couple causes the tooth to appear to tip around a point somewhat below centroid.

There are formulas in analytical mechanics that can be used to express stresses in elastic materials subjected to the actions described above. One formula would represent the stressing when force is uniformly applied over a given area. This was written as:

Stress = F_m/A_r , where F_m was a force applied at centroid

and A_r was the total projected root area.

The second formula represents the amount of fiber stress that occurs at chosen fibers in the periodontal ligament when the tooth is tipped. This was written as:

Stress = MC/I , where M was the force times the length of the moment arm. C was the distance from centroid to the particular fibers under investigation. I was the moment of inertia of the projected root area around the centroid.

These two equations were necessary to express the stress in this problem because, according to the theory of superposition, the simultaneous application of a translating force and tipping couple allowed stresses to be added provided that the maximum stress did not exceed the elastic limit of the material. In addition to this, the direction of the stressing had to be considered. The stresses in this situation were all cumulative. The mathematical expression for this was written as follows:

$$S \text{ max.} = F_m/A_r + F lg/I$$

The success in proving that the projected root theory was feasible on a two-dimensional model was important because it supported the idea of using this approach to study stresses in the case of a single rooted tooth.

D. Assessment of resisting forces in the HORIZONTAL FIBERS on a three-dimensional model.

Models I and II proved that the proposed method of calculating resisting

forces was accurate and feasible. Since the roots of natural teeth have three dimensions, it was necessary to test whether the same principles were valid when single forces were applied to three-dimensional models having a root similar to a human tooth.

The study made with Model III was restricted to two narrow bands of Durafoam --- one at the cervical region and one at the apical region to stabilize the model tooth in the alveolus. This made it easy to calculate the resisting forces by using the equations of equilibrium. This also made it possible to calculate all types of stresses in the Durafoam simultaneously. Recognition of the orthogonality of the compressive and shearing stresses was necessary to set up the formula for integrating the resultant resisting force of the ring of Durafoam. This formula was shown in the Appendix and it has been integrated both by calculus and numerically with good agreement. This analysis was an important step forward in showing how to think about the wide range and direction of stresses to which the horizontal fibers of the periodontal ligament are subjected. Agreement between the resisting forces determined by two radically different methods was good enough to validate the method of summing all stresses simultaneously.

E. Assessment of stress in the HORIZONTAL FIBERS on a three-dimensional model.

Model IV was the culmination of all the efforts of this research. It was constructed and used to complete the last phase of this study on stresses. This three-dimensional model was submitted to the same testing

as Model II, but its projected root area was much different from that of the two-dimensional model. This simple model had a rectangular projected area which was actually the area of the Durafoam. The three-dimensional model had a trapezoidal projected root area that was about 1/5th of the area of the Durafoam. It seems a little farfetched to expect to estimate the maximum fiber stresses in the conical layer of material having a trapezoidal shape but this is the simplification involved in the projected root theory. The agreement obtained by two completely different methods of calculation was close enough to validate the theory for a single-rooted tooth.

F. Appraisal of theoretical determination of the center of tipping.

A theory for determining the center of tipping was proposed by Jarabak and Fizzell. They state that, "...it is possible to substitute numerical values into the equation and to solve for the distance below the centroid at which the tipping axis would be located." The equation they proposed stated that the distance below centroid was equal to the moment of inertia divided by the distance from the point of force application to the centroid multiplied by the projected root area. This formula was used in conjunction with Model IV in which the actual center of tipping had been found. The information needed for the formula had previously been determined for the theoretical determination of the stresses. The agreement between the actual center of tipping and theoretical center of tipping was close. The findings agreed with the studies of Geigel (1965) concerning the location of the center of tipping and the variations with applied forces. This validated the method

of locating the center of tipping, by two methods, and it was a valuable step in the biophysical assessment of tooth movement.

G. The amount of compressive, tensile, and shear stresses that develop and the significance of each one.

The tensile and compressive stresses in the model ligament established in the study of Model III accounted for 77.7% of the resisting force developed by the ring of Durafoam. The shearing stresses provided the rest of the resisting force. Renfroe (1951) postulated a theory which suggested that 50% of the fibers in the ligament are resisting and 50% are relaxing during a horizontal movement of the tooth. He did not mention, however, the fibers that are undergoing shearing. The difference between the two types of stress becomes important when a tooth is subjected to force systems that produce mostly shearing stresses in the periodontal ligament. When a single-rooted tooth is rotated, most of the fibers in the periodontal ligament are stressed in shear. The modulus of rigidity is small, which means that little torque is required to turn such a tooth. It also means that the stresses applied to the walls are not high and little change takes place in them. The alveolar walls in the crest region are stressed the highest. When the rotating torque is removed, there is a strong tendency for the tooth to return to its original position.

When the same fibers are stressed in tension and compression, they build effective stresses with very little movement of the tooth and stimulate the biologic changes in the alveolar walls to cause remodeling.

CHAPTER VI

SUMMARY AND CONCLUSIONS

A. SUMMARY

1. A measuring device was designed and constructed to measure the in vivo movements of a mandibular canine when single forces of known magnitudes were applied to the crown of the tooth.
2. Forces, in 20 gm. increments from 0 to 500 gms., were applied to the chosen tooth in six patients to obtain force-deflection characteristics.
3. Many elastic materials were tested and Durafoam was selected because its force-deflection characteristics most closely resembled those of the periodontal ligament.
4. The moduli of elasticity and rigidity for the Durafoam were determined.
5. Enlarged, two- and three-dimensional analogues of a mandibular right canine were constructed, using Durafoam as a periodontal ligament, to study the resisting forces and stresses that develop in the HORIZONTAL FIBERS of the analogues.
6. Single forces of known magnitudes were applied to the crowns of analogues in a direction approximately perpendicular to the long axis of the analogues.
7. Tooth movements in a mesial-distal plane were measured by two dial-indicators. One dial-indicator measured the deflections of the crown

and the second indicator measured the deflections of the root.

8. The center of tipping was found on the analogues by using the principles of plane geometry.

9. Model I was a two-dimensional model with strips of Durafoam 1/2 in. wide, 2 in. long, placed on the analogue in areas which correspond to the horizontal and apical fibers of a periodontal ligament. This model was used to determine the amount of resisting forces that developed in the area corresponding to the horizontal fibers, when known force magnitudes were applied.

10. Model II, another two-dimensional model, had pieces of Durafoam 2 in. x 7 in. placed in it. This Durafoam corresponded to the parts of the periodontal ligament that would be stressed principally in tension and compression. The model was used to determine the amount of stresses that developed in the uppermost cervical fibers when known force magnitudes were applied to the crown.

11. Model III, a three-dimensional analogue, was used to determine the resisting forces on a 1/2 in. wide band of Durafoam in area corresponding to the horizontal and apical fibers of the tooth.

12. Model IV had three dimensions, but differed from Model III in that it had a piece of Durafoam, 6 in. high, completely surrounding the root. The stress in the most remote cervical fibers was then determined.

13. For Models I and III, resisting force values were calculated in the cervical region by two different methods, Young's formula and equations of equilibrium.

14. For Models II and IV, values of stress were calculated by two different methods, Young's formula and the formula suggested by Jarabak and Fizzell.

15. There was developed a new method of integrating the resisting stresses created within elastic material confined within an annular space when the center member is displaced.

16. The theory of the projected root area, proposed by Jarabak and Fizzell to study stress in the extreme periodontal fibers, was tested with Model IV.

17. The percentages of compression, tension, and shear in the Durafoam were determined when Model III was tipped.

B. CONCLUSION

1. A reduction in the rate of deflection in the periodontal ligament of human teeth occurred when a labial or lingual force of 180 gms. was reached.

2. Durafoam was the only elastic material that closely resembled the stress characteristics of the periodontal ligament.

3. Models I and III showed that the resisting force in the horizontal fibers of the analogue was greater than the applied force. In addition to this, the method of predicting the resisting forces proved to be very accurate.

4. From Models II and IV, it was possible to determine the amount of stress that developed when single forces were applied to the crown of a

tooth. Also, the projected root area described by Jarabak and Fizzell, was verified as a method of calculating the theoretical stresses in the periodontal ligament.

5. The location of the center of tipping was influenced by the magnitude of the applied single force. The center of tipping shifted from the apex cervically, but always remained below centroid, as the magnitude of the force was increased.

6. The location of the center of tipping depended on the point of force application. The closer the point of force application was to the incisal edge, the closer the axis of tipping was to centroid but it did not reach centroid.

7. The Jarabak and Fizzell method of determining the location of the center of tipping was found to be accurate.

8. Compression and tension constitute the major resisting force in the periodontal ligament when a tooth is tipped or translated.

9. Shear constituted the major resisting force in the periodontal ligament when a single-rooted tooth is rotated.

10. Animal research and clinical investigations must be undertaken to test the clinical applicability and validity of the physical principles used in this research and to learn how to measure quantitatively the stresses in the live periodontal ligament.

APPENDIX I

The procedure used to convert force-deflection into unit stress-unit strain and to find the modulus of elasticity, was as follows:

Unit Stress.

The formula being $S = P/A$, where P is the force in pounds, and A is the cross-sectional area of the hubs.

Example:

$$\begin{aligned} S &= P/A & P &= .441 \text{ pounds} \\ S &= .441/.5 & A &= .5 \text{ square inches} \\ S &= .882 \text{ p.s.i.} \end{aligned}$$

Unit Strain.

The formula being $e = \delta/\lambda$, where δ is the deformation in inches and λ is the original gauge length in inches.

Example:

$$\begin{aligned} e &= \delta/\lambda & \delta &= .0119173 \text{ inches} \\ e &= .0114173/.1875 & \lambda &= .1875 \text{ inches} \\ e &= .0608923 \text{ inches per inch} \end{aligned}$$

Modulus of Elasticity.

The least square formula for the goodness of fit, was used to determine what the modulus of elasticity would be.

The formula:

$$\sum x^2 / \sum xy, \text{ x is equal to unit stress and y is equal to unit strain.}$$

APPENDIX II

Center of Tipping Determination on Model I

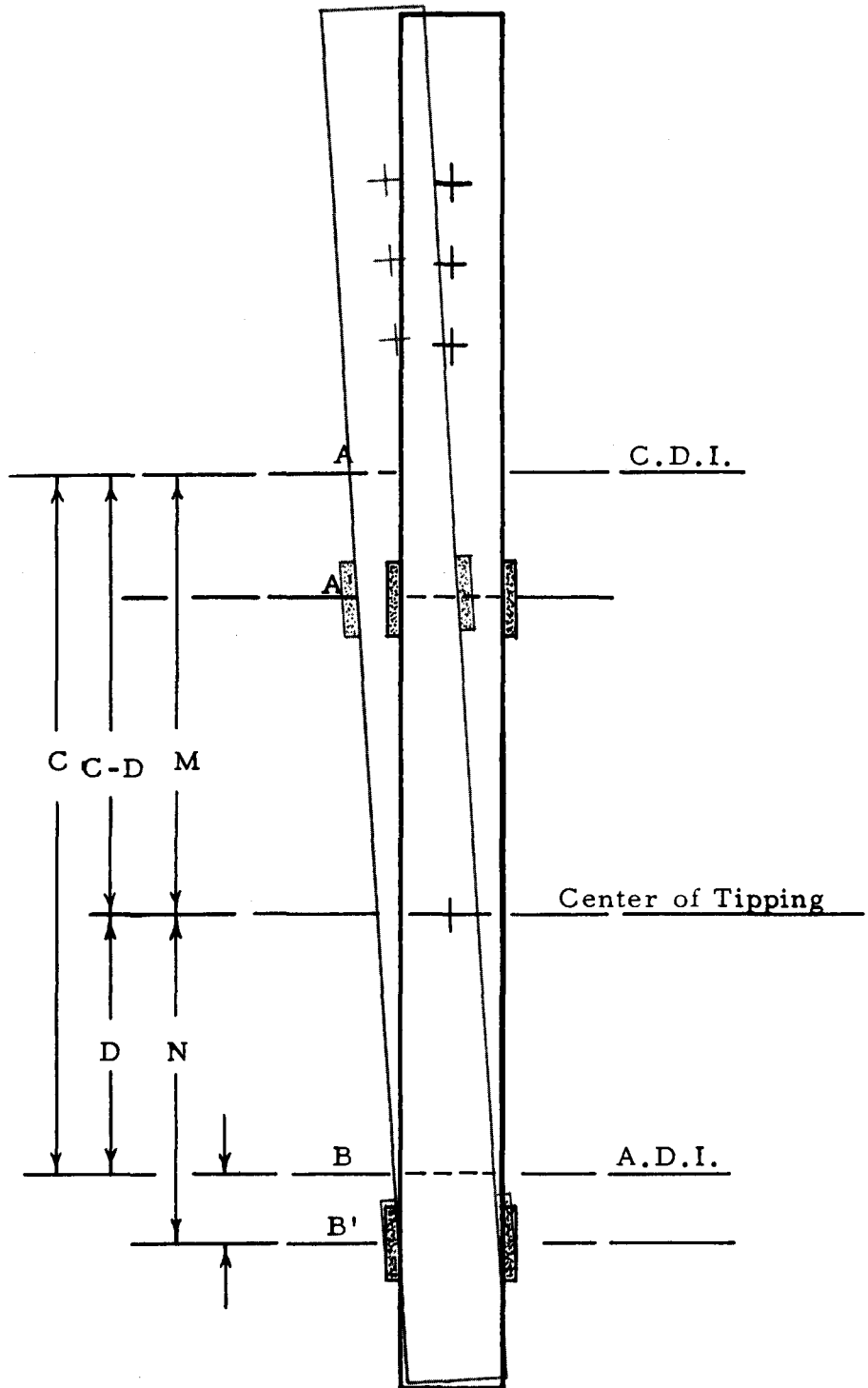

(con't.)

APPENDIX II

The following is an explanation of the letter designations of the illustration on the preceding page:

A, is equal to the deflection of the cervical dial indicator (C.D.I.).

B, is equal to the deflection of the root dial indicator (R.D.I.).

C, is equal to the distance between the two dial indicators.

D, is equal to the distance from the root dial indicator to the center of tipping.

C-D, is equal to the distance from the center of tipping to the cervical dial indicator.

K, is equal to the distance from the cervical dial indicator to the center of the Durafoam.

M, is equal to $([C-D] - K)$, the distance from the center of the Durafoam to the center of tipping.

A', is equal to the deflection at the center of the Durafoam.

Using the letter designation, the following formulas were derived to find the center of tipping (D), and the deflection of the upper Durafoam (A').

B is to D, as A is to (C-D)

$$1. AD = B(C-D)$$

$$2. AD = BC - BD$$

$$3. D(A+B) = BC$$

$$4. D = BC/A+B$$

$$5. (C-D) - K = N$$

$$6. A' \text{ is to } M, \text{ as } A \text{ is to } C-D$$

$$7. A' = A \cdot M / (C-D)$$

con't.

Appendix II (con't.)

The following is an example of the method used to find the center of tipping (D) and the deflection of the upper Durafoam (A').

From Table II, the deflection of the crown dial indicator at .5 pounds was .00644 inches and the deflection of the root dial indicator was .00019 inches.

$$D = BC/A+B :$$

$$A = .00644 \qquad C = 5.969 \text{ inches}$$

$$\underline{B = .00019}$$

$$.00663 \text{ inches}$$

$$D = .0019 \times 5.969 / .00663$$

$$D = 1.374$$

The deflection of the Durafoam in the area of this study is as follows:

$$A' = .00644 \times 2.718 / 3.593$$

$$A' = .00518$$

$$\text{when } A' = A \cdot M / C - D$$

The distance K changed on each model, but the remainder of the procedure was the same on all models.

$$\text{Model II, } K = .250 \text{ inches}$$

$$\text{Model III, } K = .557 \text{ inches}$$

$$\text{Model IV, } K = .307 \text{ inches}$$

APPENDIX III

The means of determining the actual resisting forces on Model I were:
The formula for the modulus of elasticity is unit stress/unit strain. This may be broken down into simpler expressions.

Example:

E = Modulus of elasticity (a constant)

unit stress = force/area

Resisting force (F_f = pounds) was the unknown factor and was solved for.

Here the area was one square inch (a constant).

unit strain = deflection/original gauge length (o.g.l.).

The deflection was the thickness of the material (a constant).

The modulus of elasticity was then written as:

$$E = F_f/A/defl./o.g.l.$$

The equation was solved for the unknown and rewritten in the following form:

$$F_f = (E \times deflection/o.g.l. \times area) \times 2$$

This quantity was multiplied by 2 since both sides of the model were being considered.

The following is an example of the force determination using the above formula and the information from Table II at .5 pounds:

$$F_f = (14.972 \times .005/.197 \times 1)2$$

$$F_f = .788 \text{ pounds}$$

APPENDIX IV

Resisting Force Analysis (Theoretical) on Model I

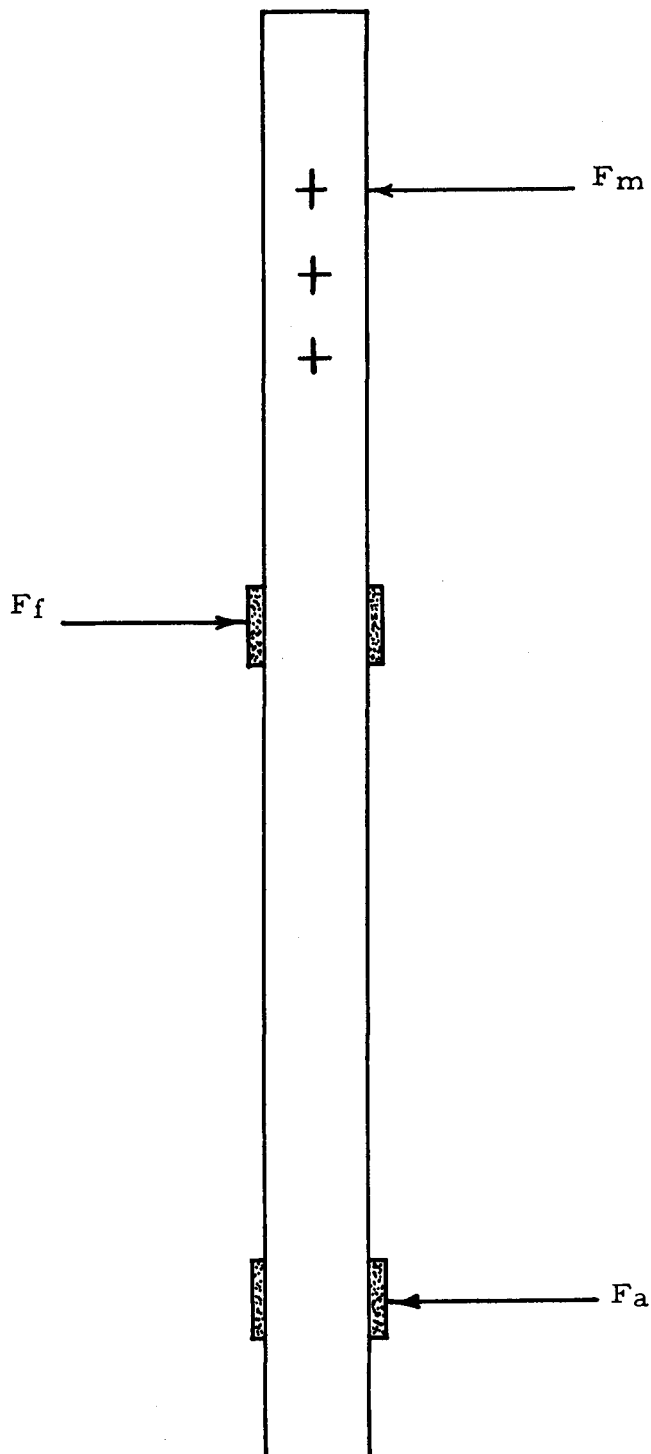

(con't.)

Appendix IV (con't.)

The equations of equilibrium were used to find the theoretical resisting force (F_f) for Model I. The letter equivalents for the drawing are as follows:

F_m , is equal to the known force applied to the crown of the tooth at the respective points of application.

F_f , is equal to the theoretical resisting force in the cervical portion of the tooth.

F_t , is equal to the theoretical resisting force at the apical portion of the tooth.

g , is equal to the distance from the point of application to the center of the cervical Durafoam.

h , is equal to the distance from the center of the cervical Durafoam to the center of the apical Durafoam.

p , is equal to the point about which moments were taken.

The equations of equilibrium were as follows:

$$\sum F_h = F_m + F_a - F_f = 0$$

$$\sum F_v = 0$$

$$\sum M_p = F_f(h) + F_m(g+h) = 0$$

$$F_f(h) = F_m(g+h) = 0$$

$$F_f = F_m(g/h + h/h) = 0$$

$$F_f = F_m(g/h + 1) = 0$$

APPENDIX V

Stress analysis (actual) Model II.

The method of stress determination used on Model II was Young's formula:

$$\text{Young's modulus (E)} = s/e$$

e is equal to unit strain which is defl./o.g.l.

Therefore, the formula may be written as (unit stress) $s = E \cdot \text{defl}/\text{o.g.l.}$ with the following equivalents:

defl. = the deflections found at the extreme cervical fibers

$$E = 14,972 \text{ p.s.i.}$$

o.g.l. = the original gage length of the Durafoam (.197)

An example of this stress determination at .5 pounds of applied force is as follows:

$$s = 14,972 (.0016/.197)$$

$$s = .127 \text{ p.s.i.}$$

For shearing stress determination, the modulus of rigidity (G) 4,275 p.s.i. substituted for (E), the modulus of elasticity 14,972 p.s.i.

APPENDIX VI

The method of theoretical stress determination on Model II followed this formula:

$$S \text{ max.} = F_m/A_r + F_m l g/I$$

where F_m = applied force

A_r = Surface area of that portion of the root which has attached the periodontal ligament.

l = The distance from point of applied force to centroid.

g = The distance from centroid to the most remote cervical fibers.

I = To the moment of inertia of the root area of the attached periodontal ligament around an axis through centroid.

An example of this follows:

$$S \text{ max.} = .25/14 + .25 \times 2.428 \times 3.5/57$$

$$S \text{ max.} = .115$$

APPENDIX VII

The resisting force determination on Model III was:

$$F_f = 4 \int_0^{\pi/2} G_{rh} \Delta X/t \sqrt{E^2/G^2 \cdot \cos^2 B + \sin^2 B} \cdot B \cdot dB$$

where,

F_f = total resisting force

G = the modulus of rigidity of the Durafoam

r = the radius of the Durafoam

h = the height of the Durafoam

ΔX = the deflection of the Durafoam at 0°

t = the o.g.l.

$\sqrt{\quad}$ = the change in compression or tension and shear from 0° to 90°

dB = the increment of integration in 5° radian (.087) measure

The answer was multiplied by four to encompass the entire area under consideration.

The integral was solved by numerical integration. The numerical integration of the radical was as follows:

Columns	1	2	3	4	5	6	7	8
Degrees	Cos B	Sin B	Cos ² B	Sin ² B	$E^2/G^2 \cos^2 B$	Cols. 4+5	$\sqrt{\quad}$	$\sqrt{\quad}$.dB
0	1.000	.000	1.000	.000	13.265	13.265	3.627	.316
5 to 90	.996	.087	.992	.007	12.172	12.129	3.479	.306
							Total	4.011

APPENDIX VIII

The method of actual stress determination for Model IV was: The Young modulus of elasticity (E).

$$E = s/e \quad s = \text{unit stress}$$

$$e = \text{unit strain}$$

$$\text{unit strain} = \text{deflection/o.g.l.}$$

The deflection was found in the same manner as described for Model I.

The o.g.l. was 0.197.

The stress was found at the most remote cervical fibers from centroid.

Therefore, the formula may be written as:

$$s = E \cdot e$$

The following is an example of the actual stress determination:

$$E = 14.972 \text{ p.s.i.}$$

$$e = .0044/.97$$

Therefore,

$$s = 14.972 \cdot (.0044/.197)$$

$$s = .677 \text{ p.s.i.}$$

APPENDIX IX

The method used for theoretical stress determination:

The same formula that was used on Model II was applied to Model IV.

$$S \text{ max} = F_m/A_r + F_m l g/I$$

The letter equivalents are the same as the formula used on Model II. See Appendix VI.

The following is an example of the theoretical stress determination:

$$S \text{ max} = 5/9.573 + 5 \cdot 5.175 \cdot 2.354/27.1275$$

$$S \text{ max} = 2.723 \text{ p.s.i.}$$

APPENDIX X

The formula used to theoretically determine the center of tipping was:

$$y = I/lA_r$$

where:

I = moment of Inertia

l = the distance from the point of force application to centroid

A_r = the projected root area

An example:

$$y = 27.127/5.175 \cdot 9.573$$

$y = .4575$ inches This is the distance below centroid where tipping will occur when a single force of a sufficient magnitude is applied at a specified distance from centroid.

3.6464 = centroid

$$- \frac{.4575}{3.1888} = y$$

3.1888 = The distance from the apex to the center of tipping.

<u>Top Post</u>		<u>Middle Post</u>		<u>Bottom Post</u>	
Theoretical	Actual	Theoretical	Actual	Theoretical	Actual
3.098	3.161	3.0064	2.912	2.875	2.738

APPENDIX XI

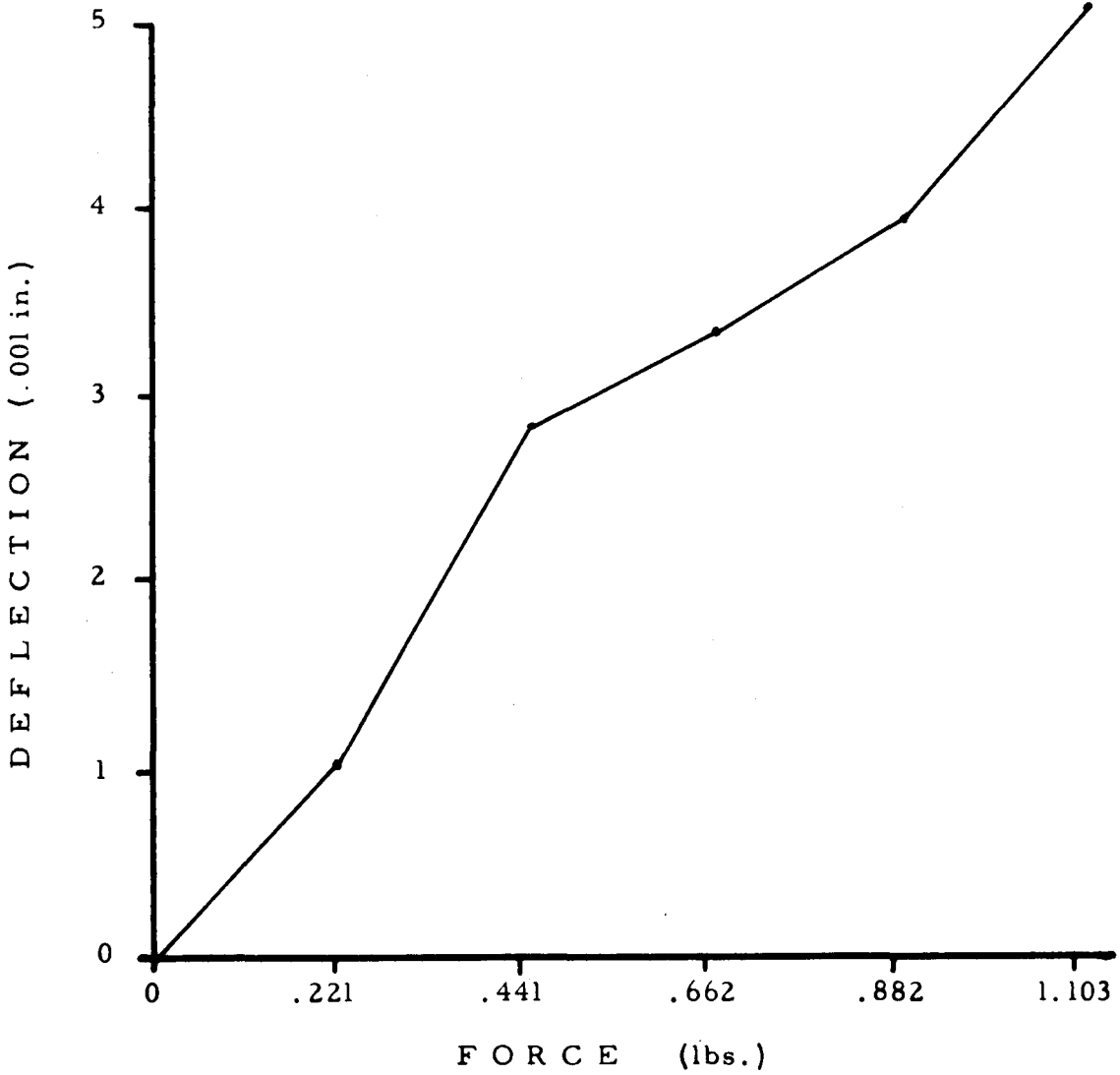

LABIAL-LINGUAL FORCE DEFLECTION CHARACTERISTIC
AVERAGE OF FOUR DEFLECTIONS OF MANDIBULAR RIGHT CANINE-
TWO LABIAL AND TWO LINGUAL
PATIENT NO. 1

APPENDIX XII

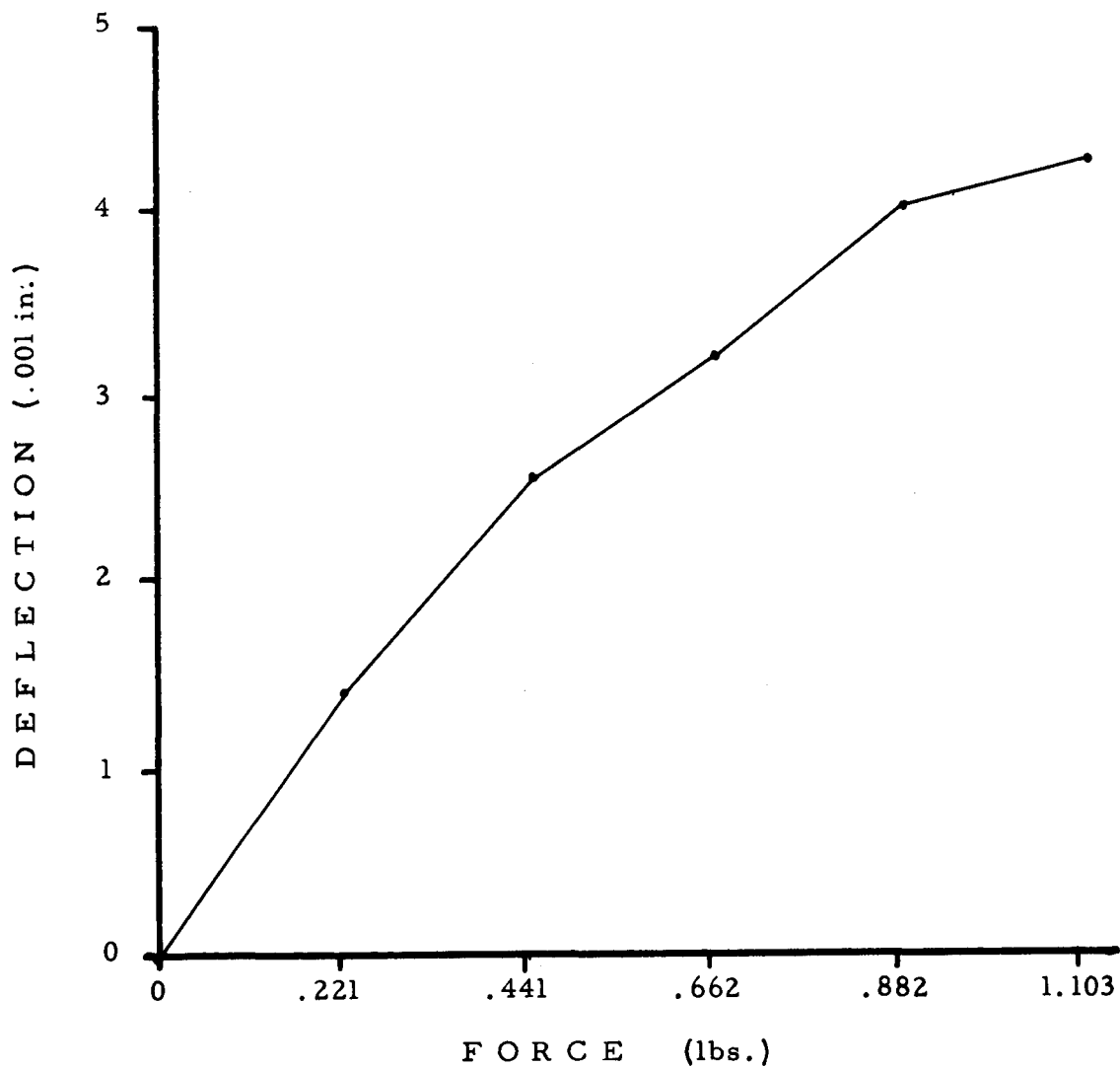

LABIAL-LINGUAL FORCE DEFLECTION CHARACTERISTIC
AVERAGE OF FOUR DEFLECTIONS OF MANDIBULAR RIGHT CANINE-
TWO LABIAL AND TWO LINGUAL
PATIENT NO. 2

APPENDIX XIII

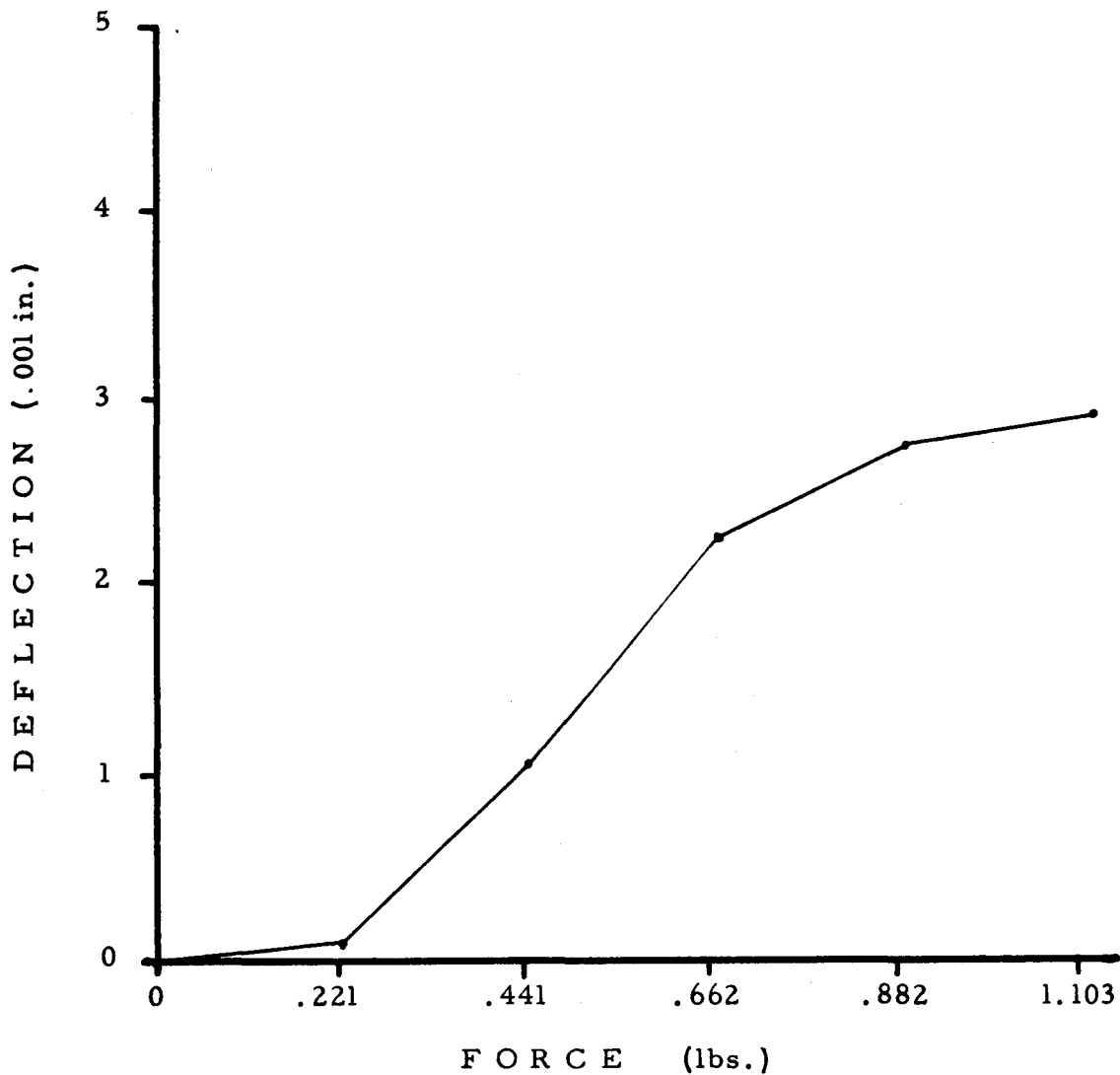

LABIAL-LINGUAL FORCE DEFLECTION CHARACTERISTIC
AVERAGE OF FOUR DEFLECTIONS OF MANDIBULAR RIGHT CANINE-
TWO LABIAL AND TWO LINGUAL
PATIENT NO. 3

APPENDIX XIV

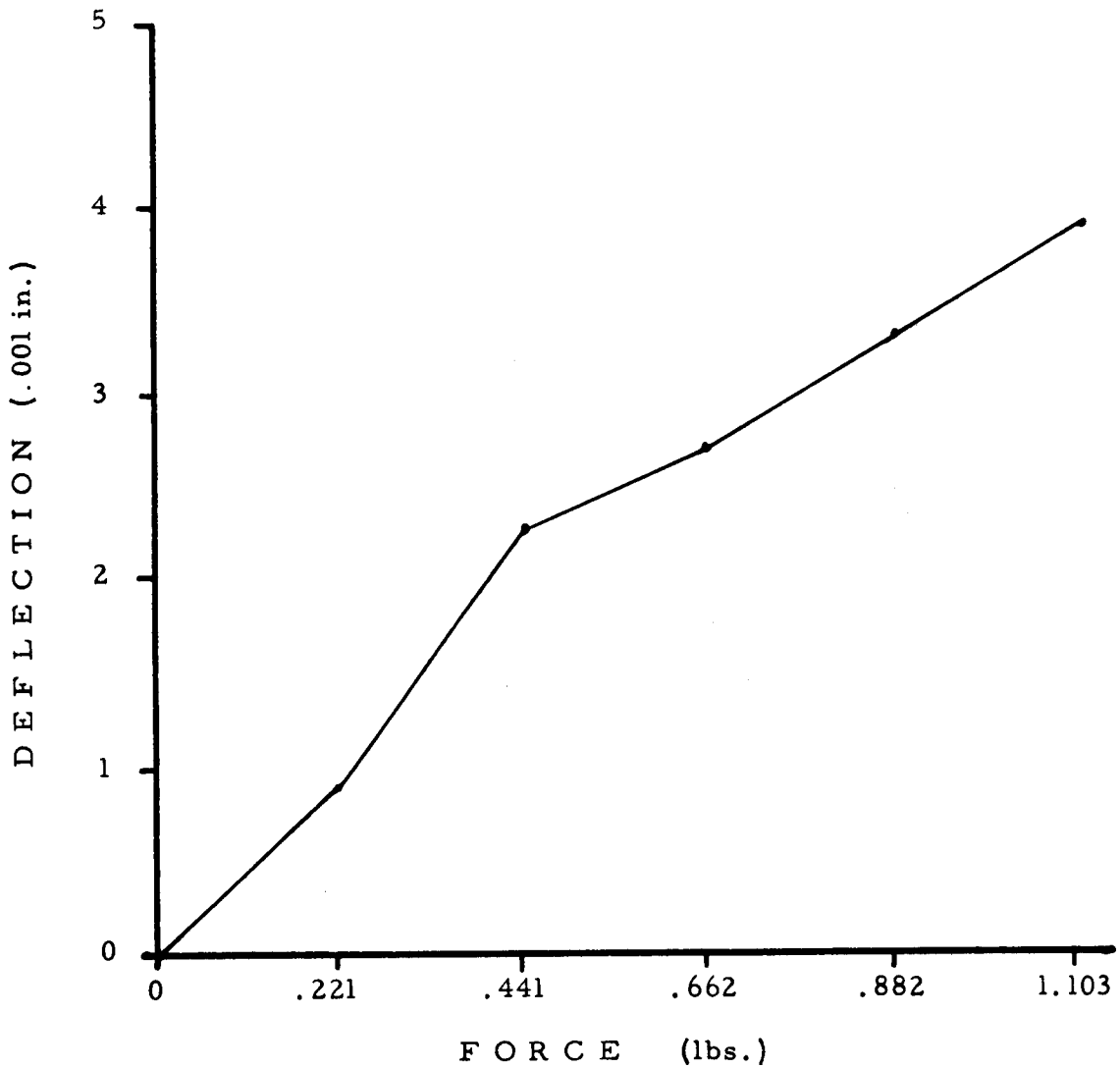

LABIAL-LINGUAL FORCE DEFLECTION CHARACTERISTIC
AVERAGE OF FOUR DEFLECTIONS OF MANDIBULAR RIGHT CANINE -
TWO LABIAL AND TWO LINGUAL
PATIENT NO. 4

APPENDIX XV

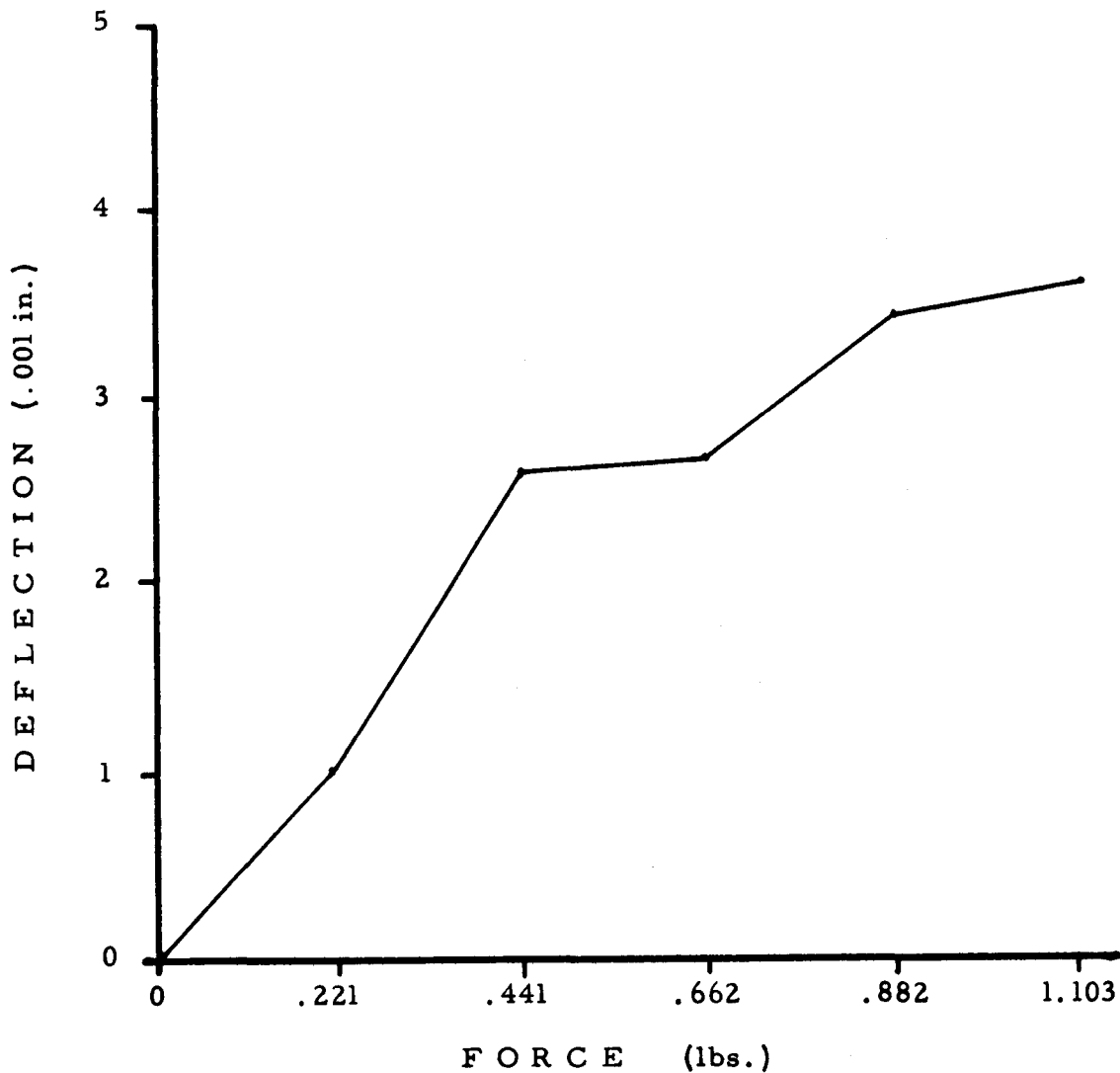

LABIAL-LINGUAL FORCE DEFLECTION CHARACTERISTIC
AVERAGE OF FOUR DEFLECTIONS OF MANDIBULAR RIGHT CANINE-
TWO LABIAL AND TWO LINGUAL
PATIENT NO. 5

APPENDIX XVI

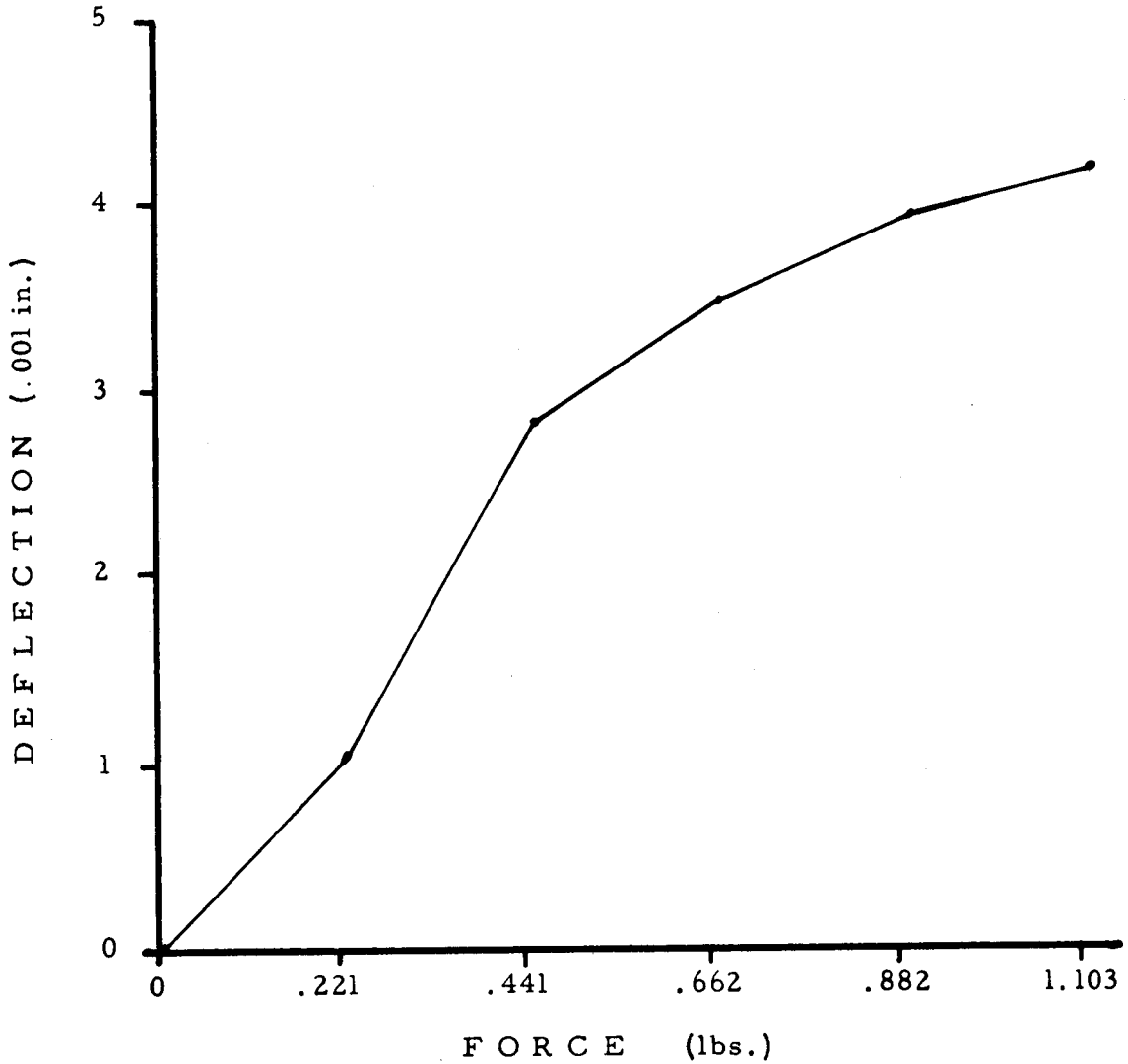

LABIAL-LINGUAL FORCE DEFLECTION CHARACTERISTIC
AVERAGE OF FOUR DEFLECTIONS OF MANDIBULAR RIGHT CANINE -
TWO LABIAL AND TWO LINGUAL
PATIENT NO. 6

GLOSSARY

- ALVEOLUS:** The bone housing the root portion of the teeth (alveolar bone).
- ANALOGUE:** That which is analogous to something. It refers to something similar in function but different in origin and structure.
- ANALOGUE, Two-Dimensional:** One in which the material being stressed is regarded as lying in a single plane of space and having two significant dimensions.
- ANALOGUE, Three-Dimensional:** One in which the material being stressed is recognized as lying in three planes of space and having three significant dimensions.
- APICAL REGION:** That area of the tooth root near the apical foramen.
- BODY:** A quantity of inert matter, the particles of which move little or not at all in relation to one another.
- CENTER OF MASS:** That point in a (three-dimensional) body about which the sum of the moments of all the individual masses constituting the body is zero.
- CENTER OF NOTATION:** A fixed point about which a body rotates.
- CENTROID:** See Centroid of Effective Root Area.
- CENTROID OF EFFECTIVE ROOT AREA:** The geometric center of the projected root area. The point around which the area is balanced. A line passing through this point, perpendicular to the long axis of the projected root area, bisects the projected root area.
- CERVICAL REGION:** That area of the tooth root immediately below the cervical line.
- COLLINEAR FORCE SYSTEM:** A coplanar force system in which the lines of action lie on the same straight line.
- COPLANAR FORCE SYSTEM:** A force system in which lines of action of the forces lie in the same plane.

COUPLE: A system composed of two forces of equal magnitude and opposite direction having lines of action which are parallel but which do not coincide.

DURATION OF FORCE: That period of time in which a force is active.

EFFECTIVE ROOT SURFACE AREA: That portion of the total surface area of the root that is involved directly in resisting the movement of a tooth in a specified direction.

ELASTICITY, Young's Modulus of: A constant of the stretch coefficient or the relationship of stress to strain.

EQUILIBRIUM, The Conditions of:

- a. the sum of the forces in an "x" direction must equal zero.
- b. the sum of the forces in a "y" direction must equal zero.
- c. the sum of the forces in a "z" direction must equal zero.
- d. the sum of the moments about a given point must equal zero.

FORCE, Deflection Characteristic: A graph relating the applied force and the resulting deflection of some member.

FORCE: Any action of one body against another which alters or tends to alter a body's state of rest or of uniform motion in a straight line.

FORCE SYSTEM: A combination of two or more forces acting on a body.

FREE-BODY DIAGRAM: A diagram that shows all of the external forces acting on a body.

FULCRUM: A fixed point against which a lever pushes. Some authors have used this term to mean center of rotation or center of tipping.

LABIAL-LINGUAL DEFLECTION: Actually the average of four deflections--two labially and two lingually.

LINE OF ACTION: A line of indefinite length of which the force vector is a segment.

MAGNITUDE OF FORCE: Measurable quality amount of force.

MOMENT OF FORCE: The product of the magnitude of a force, and the perpendicular distance from the line of action of the force to a point which is the center of rotation induced by that force.

PARALLEL FORCE SYSTEM: A force system in which the lines of action are parallel.

POINT OF APPLICATION: The point on a body at which a force is applied. The point of application of a given force acting on a rigid body may be transferred to any other point on the line of action without altering the effect of the force.

PROJECTED ROOT AREA: The area of the projection of the root of a tooth that is made on a screen that is in a plane parallel to the long axis of the tooth when the rays of light are parallel. For pure translation in the distal direction, the projection that is considered is the one that occurs when the screen is in a buccal-lingual plane and the light source is in a mesial position directed distally.

RIGIDITY, Modulus of: A constant of the stretch coefficient or the relationship of stress to strain when considering shearing stress.

SHEAR: When forces are applied to a body in such a way as to tend to cause adjacent segments to slide across each other in a straight line without rotating, that body is being stressed in shear.

STRAIN: Change in volume and/or shape of a body, or part of a body, due to applied forces. The three simplest strains are: (a) longitudinal: change in length per unit length; (b) volume: change in volume per unit volume; (c) shear: angular deformation without change in volume.

STRESS: The system of forces in equilibrium producing or tending to produce strain in a body or part of a body. Some writers regard the stresses as the force applied to deform the body and others as the equal and opposite forces with which the body resists. In all cases the stress is measured as a force per unit area. The simplest stresses are (a) tensile or compressive stress, e.g., the force per unit area of cross-section applied to each end of a rod to extend or compress it; (b) shear stress, e.g., the system of four tangential stresses applied to the surfaces of a rectangular block (each force being parallel to one edge) tending to strain it so that two of the sides become identical parallelograms, the others being unaltered in shape.

UNIT STRAIN: The relationship of deflection (in) per original gauge length (in.).

UNIT STRESS: The relationship of force (lbs.) per unit area expressed in pounds per square inch.

VECTOR: An arrow that is drawn to represent a vector quantity.

BIBLIOGRAPHY

- Adler, P.: The value of model experiments on tooth movement, American Journal of Orthodontics, 32:583, 1946.
- Ackerman, E.: Biophysical Science, Prentice Hall, Englewood Cliffs, New Jersey, 1962.
- Angle, E. H.: Treatment of the Malocclusion of the Teeth, S. S. White Company, Philadelphia, 1907.
- Bauer, W., and Lang, F. J.: Ueber das wandern der zahne, Vierteljahrsschrift fur Zahnheilkunde, 44:321, 1928.
- Burstone, C. J.: The biomechanics of tooth movement, In Kraus, B. S., and Riedel, R.A.: Vistas in Orthodontics, Lea and Febiger, Philadelphia, 1962.
- Carothers, Smith, and Calabrise: The elasticity and strength of some long bones of the human body, Project N. M., 001-056.02-13, Naval Med. Res. Inst. and Nat. Bur. of Standards, Oct. 6, 1949.
- Case, C. S.: Dental Orthopedia and Prosthetic Correction of Cleft Palate, C. S. Case Company, Chicago, 1921.
- Dempster, W. T., and Duddles, R.A.: Tooth statics: Equilibrium of a free-body, Journal of the American Dental Association, 68:652, 1964.
- Elbrecht, A.: Beitrag zur Bestimmung der Lockerungsgrade der Zahne, Paradentium, 11: 138, 1939.
- Evans and Lissner: Stresscoat, deformation studies of the femur under static vertical loading, Anat. Record, 100:159, 1948.
- Fickel, W.: Die drehachse bei einwurzligen zahnen und deren anderung bei verschiedenen belastungsrichtungen, Deutsche Monatschrift fur Zahnheilkunde, 48:1137, 1930.
- Fish, G. D.: Technology in orthodontia, International Journal of Orthodontia, 3:324, 1917.
- Geigel, E.: M. S. Thesis, Loyola University School of Dentistry, Chicago, 1965.

- Gysi, A.: Resiliency and the like in its effect on the facet angulations of artificial teeth, *Dental Digest*, 36:623, 1930.
- Haack, D. C., and Weinstein, S.: Geometry and mechanics as related to tooth movement studied by means of two-dimensional model, *Journal of the American Dental Association*, 66:157, 1963.
- Hay, G. E.: The equilibrium of a thin compressible membrane, *Canadian Journal of Research*, 17 (A):106, 1939.
- The equilibrium of a thin compressible membrane with application to the periodontal membrane, *Canadian Journal of Research*, 17(A):123, 1939.
- Ischemia of the periodontal membrane, *Oral Health*, 29:423, 1939.
- Jarabak, J. R., and Fizzell, J. A.: *Technique and Treatment with the Light Wire Appliance; Light Differential Forces in Clinical Orthodontics*, C. V. Mosby Company, St. Louis, 1963.
- King and Lawton: *Elasticity of Body Tissues in Glasser, O. Ed. Medical Physics, Vol. II, Chicago Yearbook*, 1950.
- The elasticity of soft body Tissues, *Sci. Monthly* 71:258, 1950.
- Milch, H.: Photo elastic studies of bone Form, *J. Bone and Joint Surg.*, 22:3, 1940.
- Muhlemann, H. R.: Ten years of tooth mobility measurements. *J. Periodont.* 31:110, 1960.
- O'Leary, T., and Rudd, K. D.: An Instrument for measuring horizontal tooth Mobility, *J. Periodont.*, 1:6, 1963.
- Renfro, E. W.: The Source of Power, *The Bulletin of the National Dental Association*, 16:16, 1951.
- Randall, J.: *Elements of Biophysics*, Yearbook Med. Publishers, 1962.
- Rashevsky, N.: *Mathematical Biophysics, Physico-Mathematical Foundations of Biology*, Dover Publications, Inc., N. Y., 1960.
- Schwarz, A. M.: Ueber die bewegung belasteter zahne, *Zeitschrift fur Stomatologie*, 26:40, 1928.
- Mathematische uberprufung des verhaltens belasteter zahne, *Zeitschrift fur Stomatologie*, 26: 398, 1928.

- Tissue changes incident to orthodontic treatment, International Journal of Orthodontia, Oral Surgery and Radiography, 18:331, 1932.
- Shroff, F. R.: The behavior of collagen fibers in some types of periodontal disease, Journal of Oral Surgery, Oral Medicine and Oral Pathology, 6:1202, 1953.
- Shwalb, R. A., and Rechter, A.: Application of the photoelastic method of stress analysis to orthodontic tooth movement in bone, American Journal of Orthodontics, 36:192, 1950.
- Sicher, H.: The function of the periodontal ligament, In Kraus, B. S., and Riedel, R. A.: Vistas in Orthodontics, Lea and Febiger, Philadelphia, 1962.
- Stacy, Williams, Worden, and McMorris: Essentials of Biological and Medical Physics, McGraw Hill Book Co., N. Y., 1955.
- Storey, E., and Smith, R.: Force in orthodontics and its relation to tooth Movement, The Australian Journal of Dentistry, 56:11, 1952.
- Synge, J. L.: The tightness of teeth, considered as a problem concerning the equilibrium of a thin incompressible elastic membrane, Philosophical Transactions of the Royal Society of London, Series A., 231:435, 1933.
- The theory of an incompressible periodontal membrane, International Journal of Orthodontia and Dentistry for Children, 19:567, 1933.
- Timoshenko and Goodier: Theory of Elasticity, McGraw Hill Book Co., N. Y., 1951.
- Weinstein, S., and Haack, D. C.: Theoretical mechanics and practical orthodontics, Angle Orthodontist, 29:177, 1959.
- Weinstein, S., Haack, D. C., Morris, L. Y., Snyder, B. B., and Attaway, H.E.: On an equilibrium theory of tooth position, Angle Orthodontist, 33:1, 1963.
- Werner, V.: Vergleichende Untersuchungen verschiedener Parodontose-Behandlungen mittels einer neuen metrischen Methode. Paradentium 14:43, 1942.
- Zak, B.: Die photelastische analyse in der orthodontischen, mechanik, Ztschrift fur Stomatologie, 33:22, 87, 1935.

APPROVAL SHEET

The thesis submitted by Dr. Bruce M. Nakfoor has been read and approved by three members of the faculty of the Graduate School.

The final copies have been examined by the director of the thesis and the signature which appears below verifies the fact that any necessary changes have been incorporated, and that the thesis is now given final approval with reference to content, form and mechanical accuracy.

The thesis is therefore accepted in partial fulfillment of the requirements for the Degree of Master of Science.

Date May 24, 1966

Joseph R. Jarabak
Signature of Advisor