



1981

## The Effect of Local Tetracycline Therapy on the Subgingival Microflora and Various Clinical Parameters in Juvenile Periodontitis

Frank Anthony Riccoboni  
*Loyola University Chicago*

Follow this and additional works at: [https://ecommons.luc.edu/luc\\_theses](https://ecommons.luc.edu/luc_theses)

 Part of the [Oral Biology and Oral Pathology Commons](#)

---

### Recommended Citation

Riccoboni, Frank Anthony, "The Effect of Local Tetracycline Therapy on the Subgingival Microflora and Various Clinical Parameters in Juvenile Periodontitis" (1981). *Master's Theses*. 3162.

[https://ecommons.luc.edu/luc\\_theses/3162](https://ecommons.luc.edu/luc_theses/3162)

This Thesis is brought to you for free and open access by the Theses and Dissertations at Loyola eCommons. It has been accepted for inclusion in Master's Theses by an authorized administrator of Loyola eCommons. For more information, please contact [ecommons@luc.edu](mailto:ecommons@luc.edu).



This work is licensed under a [Creative Commons Attribution-Noncommercial-No Derivative Works 3.0 License](#).  
Copyright © 1981 Frank Anthony Riccoboni

2011

THE EFFECT OF LOCAL TETRACYCLINE THERAPY ON THE  
SUBGINGIVAL MICROFLORA AND VARIOUS CLINICAL  
PARAMETERS IN JUVENILE PERIODONTITIS

By

Frank A. Riccoboni

A Thesis Submitted to the Faculty of the Graduate School  
of Loyola University of Chicago in Partial Fulfillment  
of the Requirements for the Degree of  
Master of Science

May

1981

## DEDICATION

To my loving parents, Emilio and Maria, especially for their years of support, encouragement and inspiration.

And to my wife, Judy, whose love and patience provided the motivation in completing this thesis.

## ACKNOWLEDGEMENTS

I wish to express my gratitude to Dr. Kirk Hoerman whose assistance, patience, guidance and strong friendship during all aspects of the thesis preparation were invaluable.

I wish to thank the members of my advisory committee: Dr. Anthony Gargiulo, Dr. James Hagen, and Dr. Patrick Toto for their helpful suggestions and assistance during the preparation of this thesis. In particular, a special thanks to Dr. Hagen for his assistance in the microbiological procedures undertaken in this study.

## VITA

The author, Frank Anthony Riccoboni, is the son of Emilio Riccoboni and Maria (Mezzetta) Riccoboni. He was born September 12, 1951 in Albareto, Italy.

His elementary education was obtained in the public schools of Los Altos, California, and secondary education at St. Francis High School, Mountain View, California, where he graduated in 1969.

In September, 1969, he entered the University of Santa Clara and in June, 1973, received the degree of Bachelor of Science with a major in biology and a minor in chemistry. While attending the University of Santa Clara, he received a California State Scholarship during his four years of study. He also received a Santa Clara University scholarship in 1969.

In September, 1974, he entered graduate school at the University of California at Davis. His field of interest was pharmacology and in January, 1975, as a result of his work, an abstract was published in the Pharmacologist entitled: "Characteristics of EEG Effects Produced by the Interaction of Secobarbital with Psychomotor Stimulants using Spectral Analysis Technique; (Pharmacologist, 17:2 Abst. No. 078, 1975).

He entered Loyola University College of Dentistry in September, 1975, and graduated with the degree of Doctor of Dental Surgery in May, 1979. For his efforts in dental school, he was honored by membership in Omicron Kappa Upsilon National Dental Honor Society, and in Alpha Sigma

Nu National Jesuit Honor Society.

In September, 1979, he entered the Periodontics Graduate Residency Program at Loyola University which he completed in May, 1981.

## TABLE OF CONTENTS

	PAGE
DEDICATION. . . . .	ii
ACKNOWLEDGMENTS . . . . .	iii
VITA. . . . .	iv
LIST OF TABLES. . . . .	viii
LIST OF FIGURES . . . . .	x
Chapter	
I. INTRODUCTION . . . . .	1
II. LITERATURE REVIEW. . . . .	4
A. Juvenile Periodontitis (Periodontosis). . . . .	4
B. Role of Microorganisms in the Etiology of Periodontal Diseases. . . . .	14
C. The Use of Tetracycline in Periodontal Therapy. . . . .	21
D. Sample Taking Techniques. . . . .	28
E. Rationale . . . . .	31
III. MATERIALS AND METHODS. . . . .	33
A. Selection of Patients . . . . .	33
B. Clinical Protocol . . . . .	33
C. Procedure Used for Filling Hollow Fibers. . . . .	36
D. Clinical Measurements . . . . .	39
E. Microbiological Procedures. . . . .	39

	PAGE
IV. RESULTS . . . . .	45
V. DISCUSSION. . . . .	66
SUMMARY AND CONCLUSIONS . . . . .	73
REFERENCES. . . . .	74



## LIST OF TABLES

Table	Page
1. Distribution of Microorganisms in Five Periodontosis Patients. . . . .	18
2. Distribution of Microorganisms in Periodontosis Lesions of Nine Additional Patients . . . . .	19
3. Side Effects and Toxicities of Tetracyclines. . . . .	24
4. Description of Patients and Sites Selected for Study . . . . .	35
5. Criteria for the Gingival Index . . . . .	40
6. Criteria for the Plaque Index . . . . .	41
7. Correlation of Mouth Scores to Degree of Inflammation and Plaque Accumulation . . . . .	42
8. Gingival Index Scores Over a 20 Week Period of Selected Teeth in 4 Juvenile Periodontitis Patients Treated by a Single Course of Scaling and Root Planing . . . . .	46
9. Plaque Index Scores Over a 20 Week Period of Selected Teeth in 4 Juvenile Periodontitis Patients Treated by a Single Course of Scaling and Root Planing . . . . .	48
10. Pocket Depth Recording over a 20 Week Period of Selected Teeth in 4 Juvenile Periodontitis Patients Treated by a Single Course of Scaling and Root Planing . . . . .	49
11. Gingival Index Scores Over a 20 Week Period of Selected Teeth in 4 Juvenile Periodontitis Patients Treated by Local Tetracycline Therapy. . . . .	51
12. Plaque Index Scores Over a 20 Week Period of Selected Teeth in 4 Juvenile Periodontitis Patients Treated by Local Tetracycline Therapy. . . . .	51
13. Pocket Depth Recordings Over a 20 Week Period of Selected Teeth in 4 Juvenile Periodontitis Patients Treated by Local Tetracycline Therapy. . . . .	52

Table	Page
14. Distribution of Subgingival Microflora in 4 Juvenile Periodontitis Patients. Baseline Values Obtained From two Sites Within Each Subject at a One Week Interval. . . . .	53
15. Distribution of the Subgingival Microflora in a Healthy Patient . . . . .	53
16. Percentage of Anaerobic Bacteria Over a 20 Week Period in the Pockets of 4 Juvenile Periodontitis Patients Treated by a Single Course of Scaling and Root Planing. . . . .	55
17. Percentage of Facultative Bacteria Over a 20 Week Period in the Pockets of 4 Juvenile Periodontitis Patients Treated by a Single Course of Scaling and Root Planing. . . . .	55
18. The Percentage of Anaerobic Bacteria Over a 20 Week Period in the Pockets of 4 Juvenile Periodontitis Patients Treated by Local Tetracycline Therapy. . . . .	56
19. The Percentage of Facultative Bacteria Over a 20 Week Period in the Pockets of 4 Juvenile Periodontitis Patients Treated by Local Tetracycline Therapy. . . . .	56
20. Percentage of Tetracycline-Resistant Bacteria Over a 20 Week Period in the Pockets of 4 Juvenile Periodontitis Patients Treated by a Single Course of Scaling and Root Planing. . . . .	58
21. The Percentage of Tetracycline-Resistant Bacteria Over a 20 Week Period in the Pockets of 4 Juvenile Periodontitis Patients Treated by Local Tetracycline Therapy . . . . .	58

## LIST OF FIGURES

Figure	Page
1. Informed Consent . . . . .	34
2. Dimensions of Cellulose Acetate Hollow Fibers used for Drug Delivery to the Periodontal Environment . . . . .	36
3. Placement of Drug-filled Hollow Fibers for Local Treatment of Periodontal Disease . . . . .	38
4. Patient DZ. Comparison of the Effect of Two Treatments on the Subgingival Microflora and Various Clinical Parameters over a 20-Week Period. . . . .	59
5. Patient KL. Comparison of the Effect of Two Treatments on the Subgingival Microflora and Various Clinical Parameters over a 20-Week Period. . . . .	60
6. Patient LL. Comparison of the Effect of Two Treatments on the Subgingival Microflora and Various Clinical Parameters over a 20-Week Period. . . . .	61
7. Patient SB. Comparison of the Effect of Two Treatments on the Subgingival Microflora and Various Clinical Parameters over a 20-Week Period. . . . .	62
8. Composite Graph of Patients DZ, KL, LL and SB. Comparison of the Effect of Scaling and Root Planing on the Subgingival Microflora (B) and Various Clinical Parameters (A) over a 20-Week Period . . . . .	63
9. Composite Graph of Patients DZ, KL, LL and SB. Comparison of the Effect of Local Tetracycline Therapy on the Subgingival Microflora (B) and Various Clinical Parameters (A) over a 20-Week Period . . . . .	64

## CHAPTER I

### INTRODUCTION

It is well documented that bacteria play a decisive role in the etiology of periodontal disease and that the destructive character of the periodontal lesions can be maintained only in the presence of subgingival plaque. Evidence has also been presented showing that different stages (forms) of periodontal disease are associated with varying microbial floras and that subgingival plaques in rapidly destructive periodontitis of both adult and juvenile type show a predominance of Gram-negative, anaerobic rods.<sup>1,2,3,4,5</sup>

The potential use of antibiotic therapy in the treatment of periodontitis is appealing. Several reports have been published indicating that broad spectrum antibiotics, administered via the systemic route, may be effective adjuncts in the treatment of periodontitis in man.<sup>6,7,8,9</sup> Animal experiments have furthermore revealed that daily systemic tetracycline not only changes the plaque microbiota but also reduces signs of gingivitis<sup>10</sup> and markedly inhibits the progression of alveolar bone loss<sup>11</sup> in dogs.

A fundamental principle of drug therapy is that the agent must reach the site of action in adequate concentrations to be effective and be maintained at that site for an adequate duration to allow the effect to occur. From this point of view, it would appear that a controlled

release suppository form of a drug placed within the periodontal pocket could be a highly effective method of administering antibacterial agents for periodontal therapy.

Local treatment of periodontal disease with antibacterial agents has principally been by mouth rinses and to a lesser degree, topical application in an adhesive carrier. However effective these procedures may be in reducing the formation of supragingival plaque, there is no evidence that they reach the site of action in destructive periodontal disease.

Recently, Goodson et al.<sup>12</sup> described a new system for local drug delivery in periodontal pockets. Small, permeable hollow fibers made of cellulose acetate were filled with tetracycline hydrochloride and inserted in the periodontal pockets of a patient with generalized gingivitis associated with high levels of spirochetes. This treatment dramatically changed the periodontal microflora and rapidly decreased clinical signs of periodontal pathology. Using a similar delivery system, Lindhe et al.<sup>13</sup> treated five patients with severe periodontitis and found corroborating results to Goodson's earlier study. Furthermore, Goodson et al.<sup>12</sup> showed that a therapeutic effect was obtained by the administration locally of less than 1/1000 of the amount of tetracycline that would have been used for systemic therapy. The significance of these studies are apparent since the side effects associated with systemic tetracycline were virtually eliminated.

The present investigation was aimed at assessing the effect of tetracycline, locally administered via hollow fiber devices, on the

subgingival microflora of periodontal pockets and on clinical parameters describing health and disease in four patients with clinical features of juvenile periodontitis.

## CHAPTER II

### LITERATURE REVIEW

#### A. JUVENILE PERIODONTITIS (Periodontosis)

14

Juvenile periodontitis is an infrequently seen periodontal disease characterized by a rapid, vertical loss of alveolar bone around the permanent first molars and incisor. The rapidity and severity of destruction of the periodontal ligament and associated supporting structures are not directly proportional to the local (extrinsic) factors. The disease affects adolescents who are apparently healthy, and the condition is seen in early childhood. Although the consistent finding of molar-incisor bone loss is pathognomonic in affected juveniles, other teeth can be involved in this aggressively osteolytic disease.

15

Gottlieb (1923) was the first to describe juvenile periodontitis and he called it "the diffuse atrophy of the alveolar bone". He made a distinction between two types of "alveolar-pyorrhoeas," diffuse atrophy and marginal atrophy. The first is known today as juvenile periodontitis and the second as chronic marginal periodontitis. Gottlieb reported diffuse atrophy in a fatal case of epidemic influenza in a 22 year old man. In this case he found no pathologic changes in the gingival tissues but the periodontal spaces were widened at the apices due to resorption of the alveolar bone and cementum. The periodontal ligament had lost its functional structure and had changed into loose connective tissue. In

the marginal type of atrophy, suppuration and inflammation were suggested to be early symptoms with loosening following later. In diffuse atrophy, splaying and loosening were early symptoms, while pocket formation and suppuration appeared relatively late. Later, Gottlieb (1928)<sup>16</sup> changed the name of the condition to deep cementopathia (cementopathia profunda) because he believed that the original defect was in the cementum.

Ten years later, Wannemacher (1938)<sup>17</sup> stated that the associated bone resorption appeared most likely in the incisor and first molar areas, the developmentally oldest periodontal tissues. He called the disease "parodontitis marginalis progressiva". It is interesting that, while all other investigators spoke of a noninflammatory or degenerative disease, he pointed out the domination of an inflammatory process. He noticed, that even when there were deep pockets, the gingiva looked healthy and pale pink but that there was some bleeding on probing with a blunt instrument. This condition was later reported in the United States by Miller, et al.<sup>18</sup> and the fusion of these two views has yielded today's concept of juvenile periodontitis.

A later term for the disease was "paradontosis," used by Thoma and Goldman (1940).<sup>19</sup> They pointed out that it should be carefully distinguished from marginal periodontitis. According to these authors the first characteristics of paradontosis were migration of the maxillary incisors accompanied by loosening of the teeth. Pocket formation was due to the breakdown of the principal fibers of the periodontal membrane allowing the epithelium to proliferate along the cementum. This



breakdown was due to resorption of the alveolar bone and the wandering was a result of the proliferation of the connective tissue which replaced the resorbed bone. This proliferation displaced the tooth. Occlusion would influence the direction in which the teeth migrate and determine where the pockets formed.<sup>19</sup>

The English term "periodontosis", which is still used by many many authors, was coined by Orban and Weinmann (1942).<sup>20</sup> They considered the disease more degenerative than inflammatory in origin. They described essentially the same clinical symptoms as mentioned earlier: migration of the teeth and subsequent inflammation and pocket formation. However they divided the disease into three stages. The first two stages were clinically indistinguishable in that no inflammation or pocket formation appeared. These two stages presented the true periodontosis whereas the third stage, with inflammation and pocket formation (also called the periodontitis complex), was actually a periodontosis complicated by periodontitis.<sup>19</sup> While Thoma and Goldman (1940) claimed that periodontosis was a disease of early and middle life, Orban and Weinmann (1942)<sup>20</sup> stated that females were more susceptible to this disease between the ages of 10 and 25, whereas males would not be affected under the age of 30. The nomenclature Committee of the American Academy of Periodontology (1950)<sup>21</sup> also refers to periodontosis as a "degenerative non-inflammatory destruction of the periodontium originating in one or more of the periodontal structures, characterized by migration and loosening of the teeth in the presence or absence of secondary epithelial

proliferation and pocket formation or secondary gingival disease".

Tenenbaum et al. (1950)<sup>22</sup> pointed out that the disease occurred predominantly in adolescent females. They reported that radiographic examination revealed a loss of alveolar bone that followed a definite arch form pattern starting from the mesial surfaces of the second molars and extending to the distal surfaces of the second bicuspid. There was bone loss also in the incisor area while the alveolar bone showed the greatest resistance in the mandibular bicuspid area. McCall (1951)<sup>23</sup> commented that, because the incisors and first molars were the first teeth to erupt and thus exposed to occlusal stress for the longest time, they should also show the first and most severe signs of alveolar weakness. The susceptibility of the different teeth to chronic marginal periodontitis followed a different pattern; upper molars, lower molars, upper bicuspid, lower incisors, upper incisors and canines, lower canines and first bicuspid. In his critical evaluation of periodontosis, Glickman (1952)<sup>25</sup> added a few more points to the radiographic features: "thickening of the periodontal space; absence of haziness of the lamina dura; destruction of the interdental septa of the alveolar bone in a vertical rather than horizontal direction; a generalized alteration in the trabecular pattern of the alveolar bone consisting of less defined trabecular markings and increase in the size of the cancellous spaces."

Since several investigators have pointed out that the etiology of periodontosis must be systemic<sup>18,19,23</sup> Glickman and his coworkers (1952)<sup>25</sup> undertook a series of animal experiments to explore how systemic

factors influenced the chronic destructive periodontal disease. They found that factors such as short-term starvation, vitamin C deficiency, protein deprivation, and experimental diabetes could produce alveolar bone loss without gingival inflammation. Gingival inflammation increased bone destruction but the alveolar bone is not necessarily the only tissue involved, nor need it be the tissue in which the destructive changes are primarily manifested.

In their review, Yount and Belting (1956)<sup>26</sup> described the clinical picture of the disease. In the first degenerative stage no pockets were detectable clinically, even if there was radiographic evidence of the vertical type of bone destruction. The gingival tissue were pale pink, firm and relatively little calculus was present. Later, when the pockets had developed, the gingival tissues could still present the normal pale pink appearance. When the disease first progressed to the late inflammatory stage, subgingival calculus deposits became abundant and pus could be freely pressed from the pockets. They also stated that it was common clinical experience that many patients with periodontitis were caries immune.

In the Michigan Workshop in Periodontology, 1951, the question arose as to whether periodontosis is a clinical entity or not. The Nomenclature and Classification Committee of the American Academy of Periodontology (Lyons et al. 1959)<sup>27</sup> considered that no convincing human studies had been published to establish the pertinent histopathologic changes. It was emphasized, at that time, that it is not an entity

caused by systemic factors, but that these changes are produced by occlusal trauma. In traumatism there is degeneration of the periodontal membrane and proliferation of the epithelial rests. Ramfjord, (1961)<sup>28</sup> also stated that there is always evidence of the presence of inflammation in a periodontal pocket. It was concluded that the classification of periodontosis as a clinical manifestation should be retained.

Some years later it was noted by Baer and coworkers that despite the fact that many periodontists did not believe in the existence of such an entity, "to us periodontosis means advanced alveolar bone loss around one or more of the permanent teeth in an otherwise normal, healthy adolescent"<sup>29,30</sup>. Though Baer reported only a single case, it was well documented and marked the starting point of the development of the present concept of juvenile periodontitis.

Seidler and coworkers (1950)<sup>31</sup> examined, most carefully, the pattern of the bone loss. They stated that in the older age groups the bone destruction affected almost all the teeth but that in younger individuals only the first molars and incisors were affected. Their opinion was shared by Hormand and Frandson (1976)<sup>32</sup>. Pritchard (1965)<sup>33</sup> did not believe that a degenerative process could affect only the periodontal apparatus, leaving other body structures intact. He also stressed that there was no pocket formation without inflammation, regardless of the severity of occlusal traumatism. The final stage was reached when local irritants had caused periodontitis and pocket formation had developed. Thus periodontosis was a disease that no one had ever seen before it

developed into juvenile periodontitis. The World Workshop in Periodontics (1966)<sup>34</sup> concluded that the term periodontosis should be eliminated from the nomenclature because there is not sufficient evidence to identify it as a specific disease entity.

Two years later, in a thorough review, Kaslick and Chasesn (1968)<sup>35</sup> launched a new term, "periodontosis with periodontitis", and considered it to be a clinical entity. They studied 27 U.S. Army recruits having periodontosis with periodontitis. They found that there were two different types of calculus formation, one with little or no subgingival calculus but with severe bone loss and one with heavy calculus formation but with less bone destruction. Another interesting finding was the "mirror image" pattern of connective tissue loss observed on corresponding teeth extracted from opposite sides of the mouth. They concluded that this symmetrical bilateral loss of periodontal ligament appeared to give supportive evidence to the idea that periodontosis could be a hereditary or developmental defect. Contrary to the views of earlier authors, they did not find that occlusal discrepancies had any primary role in the development of "periodontosis with periodontitis". In a subsequent study, Kaslick and coworkers (1971)<sup>36</sup> noticed that the same "mirror-image" pattern was also found in cases with widespread bone loss and not only in the first molar-incisor types. Therefore, they concluded that both kinds of cases belonged to the same category of periodontosis with periodontitis. In the same study they analyzed the gingival fluid and found that the fluid from moderately inflamed areas with an underlying periodontosis

had higher potassium values than in controls. They stated that the presence of periodontosis appeared to raise the gingival fluid potassium level and lower the sodium/potassium ratio. Stein (1969)<sup>37</sup> made a clinical evaluation of five cases of periodontosis and his findings supported those of earlier investigations: local irritants could not easily explain the periodontal condition. Mobility, gingival inflammation and the incidence of caries varied considerably and the only consistent finding was an advanced vertical resorptive alveolar defect involving incisors and/or first molars. In radiographs these lesions were seen unilaterally, bilaterally or contralaterally.

Baer (1971)<sup>38</sup> discussed the definition of periodontosis by the Nomenclature Committee of the American Academy of Periodontology (1950) and gave as his definition of the disease: "Periodontosis is a disease of the periodontium occurring in an otherwise healthy adolescent, which is characterized by a rapid loss of the alveolar bone about more than one tooth of the permanent dentition. There are two basic forms in which it occurs. In one form, the teeth affected are the incisors and the first molars, in the other, more generalized form, most of the dentition can be affected. The amount of destruction manifested is not commensurate with the amounts of local irritants present". He pointed out several distinctive features of this disease which justify its classification as a clinical entity different from chronic marginal periodontitis:

1. Age of onset (early puberty, between 11 and 13 years)
2. Sex ratio (female/male ratio 3:1 according to Benjamin and Baer 1967)<sup>39</sup>

3. Familial background
4. Lack of relationship between local etiologic factors and presence of deep periodontal pockets
5. Distinctive photographic patterns of alveolar bone loss
6. Rate of progression
7. Lack of involvement of primary teeth

However, Baer (1971)<sup>38</sup> stated that, in extracted teeth affected by periodontosis, microscopic examination revealed plaque adhering to the root surfaces, suggesting that local irritants were present, but in minimal amounts. Radiographically, the buccal and lingual plates of the alveolar bone were the last to resorb, i.e. the bifurcation involvements were late manifestations of the disease. In another study, third molar tooth buds were transplanted into sockets of freshly extracted first molars with resultant complete healing of the bone.<sup>40</sup> The same experience was reported by Borring-Moller and Fransden (1978)<sup>41</sup> who performed similar tooth transplantations in eight patients with juvenile periodontitis and followed them for seven years. No pocket depths over 3 mm were found in any abnormal mobility of the teeth. Both these studies make doubtful any primary role of the bone in this disease.

The term "juvenile periodontitis" was introduced into the English literature by Butler (1969).<sup>42</sup> In France the term "acute juvenile periodontitis" had been used since 1967 by Chaput.<sup>43</sup> In addition, Bouyssou and Fourel (1973)<sup>44</sup> discussed the terminology on the basis of their own studies and considered the term "juvenile periodontitis" more correct

than "periodontosis". However, Fourel (1974)<sup>45</sup> published a report of four cases of juvenile periodontitis and proposed to call the disease "Gottlieb syndrome". Manson and Lehner (1974)<sup>46</sup> emphasized the correctness of the term "juvenile periodontitis" on the following grounds: (1) there was no evidence of a degenerative process; (2) it emphasized the principally clinical feature of the disease and its development in young individuals; and, (3) there was evidence that the disease differed from adult periodontitis as far as its immunological background was concerned.<sup>47</sup> The oldest group in their study consisted of patients 22 to 29 years of age and their condition was called "post juvenile periodontitis".

Sugarman, et al. felt that the term "periodontosis" should be discarded because the entity was a periodontitis: in all cases plaque had been found on the root-surfaces of the involved teeth.<sup>48</sup> The disease differed from the chronic marginal periodontitis in some of its characteristics and etiology but should be treated like periodontitis and the prognosis was commensurate with the stage to which it has advanced. Werhaug (1976, 1977),<sup>49,50</sup> who also preferred to use the term "juvenile periodontitis" in his studies on autopsy material and on extracted teeth, showed that there was always a thin layer of subgingival plaque which advanced apically at a maximum rate of 5 microns per day, i.e. 1.8 mm a year. He also noticed that buccally and lingually, there was no supra-<sup>49</sup>gingival plaque, subgingival plaque nor bone loss. He concluded that rather than a degenerative process there must be some deficiency in the



host defense mechanism which allowed the exaggerated destructiveness. It was further claimed that the disease should actually be called "destructive juvenile periodontitis". In another study, he found that cases of "periodontosis" responded to complete plaque removal as did cases of chronic marginal periodontitis but that incomplete plaque removal led to rapid bone loss.<sup>51</sup>

In 1977 the committee of Nomenclature of the American Academy of Periodontology published a Glossary of Terms recommended for use, which quoted: "Periodontosis: A degenerative disease of the periodontium, existence of which is not accepted universally." "Juvenile periodontitis: see periodontosis". And there the issue stands today.

#### B. ROLE OF MICROORGANISMS IN THE ETIOLOGY OF PERIODONTAL DISEASES

Over the past 20 years abundant evidence has been accumulated to implicate microorganisms at the primary etiologic agents of various forms of periodontal disease.<sup>52,53,54,55,56</sup> The classic studies of Löe and co-workers<sup>57</sup> clearly demonstrated that accumulations of plaque on the teeth preceded and initiated gingivitis in humans, and furthermore, that gingival inflammation was eliminated after a plaque removal regimen was instituted. Antiseptic agents have also been used to control plaque accumulations and thereby prevent, or reverse, clinical gingivitis in human volunteers. However, only over the last decade as a result of improved sampling, dispersion and culturing techniques has more attention been focused on the specificity that apparently exists between microorganisms and the various disease states.

The healthy gingival sulcus in humans is associated with a comparably meager microbial flora consisting of a relatively thin layer of adherent bacterial cells, the majority of which are Gram-positive cocci and filaments.<sup>60,61,62</sup> The organisms most frequently encountered in the healthy gingival site include Streptococcus sanguis, Streptococcus mitis, Actinomyces viscosus, Actinomyces israelii, Actinomyces naeslundii,<sup>61,62</sup> Staphylococcus epidermidis and Rothia dentocariosa.

By comparison, gingivitis is characterized by a quantitative increase in the total mass of adherent microorganisms that may be several hundred microns thick.<sup>60</sup> In experimental gingivitis, organisms of the genus Actinomyces frequently comprise 50% or more of the isolates recovered.<sup>63</sup> In moderate gingivitis, Gram-negative microorganisms have been frequently recovered. They include Veillonella, Campylobacter,<sup>3</sup> Fusobacterium and several Bacteroides species.

Recently in a study of the microflora associated with long-standing gingivitis, Gram-negative anaerobic rods comprised 25% of the total cultivable microflora. These included species of Fusobacterium, Bacteroides, and Selenomonas.<sup>62</sup> A Gram-negative facultative organism identified as Haemophilus parainfluenza comprised 15% of the cultivable microbiota. However, the majority were Gram-positive organisms including Actinomyces viscosus, Actinomyces naeslundii, Actinomyces israelii, Streptococcus mitis, and Streptococcus sanguis.<sup>62</sup>

In contrast, Gram-negative, anaerobic or microaerophilic, asaccharolytic rods predominate in the microbiota associated with rapidly

destructive periodontitis. Bacteroides melaninogenicus ss. asaccharolyticus has been the most frequently isolated organism associated with advanced periodontitis.<sup>64</sup> Other organisms which have been associated with the rapidly destructive lesions are Fusobacterium nucleatum, Fusobacterium gonidiformans, anaerobic vibrios, "corroding" Bacteroides, Eikenella corrodens, and a newly described group of fusiform-shaped "gelatin-loving" Bacteroides.<sup>64</sup> Morphologic studies of plaque associated with advanced periodontitis have further characterized this microbiota and have revealed distinctive and complex microflora.<sup>60</sup> In 1973, Newman, et al. investigated the microbiota in one individual with juvenile periodontitis.<sup>65</sup> It was observed that it was quite different in a 10 mm deep pocket than in a normal site with a pocket depth of 2 mm. In the normal site in the same individual it was the same as a healthy individual's and consisted primarily of Streptococcus sanguis, Staphylococci, Veillonella and Gram-positive rods, whereas in the pathological sites the microbiota was dominated by Gram-negative anaerobic rods. The rods could be divided in two distinguishable types; a motile, curved, fermentative rod and a pleomorphic small rod. Thus, it seemed that the two different types of periodontal disease were caused by different groups of microorganisms. Later, Newman, Socransky and Listgarten, were able to divide the Gram-negative organisms into five groups, none fitting that description of existing species.<sup>5</sup> A year later, Savitt, et al. characterized the five different groups of anaerobic Gram-negative rods.<sup>66</sup> None of the lesions included all five types simultaneously; mostly three or four of the special groups

were present. Tests on humoral antibody titers to these microorganisms suggested that groups II and III could be specific for juvenile periodontitis. However, Slots (1976)<sup>4</sup>, whose results were similar, suggested that the role of the Gram-negative rods in the etiology of juvenile periodontitis was still unknown. Tables 1 and 2 show the results of Newman and Socransky's study (1977)<sup>67</sup> showing the distribution of microorganisms in periodontosis lesions of 5 and 9 patients, respectively. The results indicated a significantly increased proportion of Gram-negative anaerobic rods when compared to a predominantly Gram-positive flora in the control sites.

Table 1

Distribution of Microorganisms in Five Periodontosis Patients\*  
(Mean Percent)

Patient	Healthy Site					Pathologic Site (Pocket)									
	1	2	3	4	5	1	1	2	2	3	3	4	4	5	5
GRAM POSITIVE															
Aerobic & Facultative Cocci	14	54	37	25	28	17	18	6	7	5	7	13	4	5	15
Anaerobic Cocci	9	12	8	10	5	5	8	17	9	12	8	12	9	0	10
Aerobic & Facultative Rods	0	12	11	15	5	19	26	0	20	0	3	1	0	0	0
Anaerobic Rods Pairs	77	0	16	15	27	12	0	19	12	21	12	10	26	17	0
						15									
GRAM NEGATIVE															
Aerobic & Facultative Cocci	0	2	3	4	0	1	4	9	12	0	0	3	2	0	0
Anaerobic Cocci	0	16	19	20	8	4	10	17	6	2	10	21	11	4	0
Aerobic & Facultative Rods	0	0	0	1	0	2	4	6	6	0	0	2	0	0	0
Anaerobic Rods	0	4	7	10	27	25	30	26	28	60	62	38	50	74	75
Sample Depth in mm.	2	2	2	2	2	5	9	9	8	9	9	9	9	9	9
Isolates Characterized	24	52	28	20	32	30	30	30	30	25	30	25	25	30	30

\* Adapted from Newman, M.G. and Socransky, S.S., 1977.

Table 2

Distribution of Microorganisms in Periodontosis Lesions of Nine Additional Patients\*  
(Mean Percent)

Classification Group	Patient								
	1	2	3	4	5	6	7	8	9
Gram Positive Cocci									
Facultative	5	9	10	20	10	6	14	7	16
Anaerobic	5	-	-	3	5	-	6	9	15
Gram Positive Rods									
Facultative	10	8	12	3	10	19	10	10	4
Anaerobic	10	5	10	24	10	10	8	8	4
Gram Negative Cocci									
Facultative	-	-	-	-	-	-	-	-	-
Anaerobic	-	-	8	7	15	10	9	11	16
Gram Negative Rods									
Facultative	-	-	-	-	-	3	-	10	-
Anaerobic	70	78	60	43	50	52	53	45	45

\* Adapted from Newman, M.G. and Socransky, S.S., 1977

The morphology of plaque in chronic periodontal disease and juvenile periodontitis was studied using an electronmicroscope by Listgarten (1976).<sup>60</sup> In the latter he found a sparse, predominately Gram-negative flora and a unique electron-dense, lobulated cuticular deposit covering most of the samples. In the "postperiodontosis" group, which meant patients older than 21 years, samples of the microflora were much more similar to the periodontitis group. Krekelei and Frick (1977)<sup>68</sup> counted the number of micro-organisms in the gingival fluid in healthy and diseased gingivae. They observed that when the Gingival Index (Loe and Silness) was 0-2 there was a positive correlation between the inflammation and the count of the micro-organisms, but when the grade of inflammation increased above this there was a significant reduction in the bacterial count. The same thing occurred when the pocket depth exceeded 4.5 mm.

In his extensive review article on the microbiology of periodontal disease, Socransky (1977)<sup>1</sup> characterized the Gram-negative bacteria more specifically and proposed a new genus of Capnocytophaga. The latest research from this group was concerned with mono-infection of germ-free rats with these Gram-negative microbes. They showed that Capnocytophaga caused periodontal disease between first and second maxillary molars with apical migration of the epithelial attachment, destruction of the alveolar bone by osteoclasts and impaction with debris.<sup>69,70</sup>

More recently, Tanner, et al. (1979)<sup>71</sup> described a Gram-negative, short, slightly curved, round ended, capnophilic rod called Actinobacillus

actinomycetemcomitans. This organism was recognized in high proportions in advanced destructive periodontal disease of young adults. Strains of group III and group IV organisms from periodontitis patients described by Newman and Socransky (1977)<sup>67</sup> were shown by Tanner to also be strains of A. actinomycetemcomitans. Thus, the organism had been found in high proportions (10-30%) in young individuals with advanced destructive periodontal disease.

In view of the well-established participation of bacteria in the etiology of periodontal disease, it would be plausible that the microbial contents of the gingival sulcus and in a pocket might reflect not only the state of health of the periodontium, but also the presence or absence of active disease. Although cumbersome, it has been shown by culturing techniques and by simple morphologic classification that significant differences can be demonstrated between the microflora at periodontically diseased and relatively healthy sites. Such techniques could be used to monitor changes in the microflora of patients undergoing periodontal treatment. It should be possible to determine if a flora, normally associated with a diseased site, can be shifted to one which is normally found at a healthy site and to study the concomitant alterations which take place in various clinical parameters routinely used in assessing the clinical status of the periodontium. This idea formed the basis of the present investigation.

### C. THE USE OF TETRACYCLINE IN PERIODONTAL THERAPY

As previously stated, it is thought that gingival health is



associated with a Gram-positive, predominantly coccal flora with few spir-  
<sup>67,72</sup>ochetes present. A specific Gram-negative rod, Bacteroides asachar-  
olyticus, is associated with advanced periodontitis in adults, accompanied  
<sup>71</sup>by severe inflammation and purulence. Bacteroides melaninogenicus ss.  
intermedium predominates in deep pockets with minimal inflammation and an  
<sup>71</sup>absence of purulence. Isolates from cases of juvenile periodontitis  
<sup>67</sup>show significant increases in Capnocytophaga and Actinobacillus actino-  
<sup>67,73</sup>mycetemcomitans.

It is a logical hypothesis that antibiotics could effect a change  
in the composition of subgingival plaque if adequate and therapeutic  
levels are reached in the gingival fluid and saliva.

Tetracycline, a broad spectrum bacteriostatic agent used in the  
treatment of long-term bacterial diseases such as acne vulgaris and cystic  
fibrosis, has been used recently as an adjunct in the treatment of perio-  
dental disease. The basis for selection of tetracycline has been its  
broad spectrum, low incidence of patient sensitivity, and favorable safety  
records. Of equal importance are two studies which have shown, qualita-  
<sup>74,75</sup>tively, that tetracyclines pass into gingival crevicular fluid. In  
one study, tetracycline concentration was quantified in gingival crevicu-  
<sup>76</sup>lar fluid, and in the second study in saliva and tears. <sup>77</sup>Tetracycline  
has been used as an adjunct in the management of periodontitis in juven-  
iles and aggressive forms of the disease in adults at very high doses  
(1 gram/day) for short periods (10-14 days) or at lower doses (250-500  
mg/day) for extended periods.

78

In 1976, Ciancio published a review article on the use of tetracyclines in dentistry including its indications, contra-indications, interactions and possible applications in human research.

Table 3 illustrates the possible side effects and toxicities of the tetracyclines.

Table 3. Side Effects and Toxicities of Tetracyclines\*

Teeth	Permanent discoloration, dysgenesis due to administration of tetracycline during last half of pregnancy or first 6 years of life.
Bone	Possible retardation of growth and development-may be transient.
Gastrointestinal tract	Overgrowth with monilial microorganisms has been reported on a number of occasions in conjunction with tetracycline therapy. However, some articles question this statement. Alteration in absorption of vitamin K may occur leading to inadequate formation of prothrombin-bleeding problems may follow.
Liver	Lethal hepatic toxicity has been reported in conjunction with use in pregnancy, shock and sepsis. Abnormal liver function tests have been reported.
Blood urea nitrogen	Elevation of blood urea nitrogen has been reported and appears to occur mainly in patients taking diuretics or presenting initially with a high blood urea nitrogen. Nausea, vomiting and the sequelae are associated with this rise.
Renal	Azotemia. Also, renal disorders have been reported following administration during pregnancy. A Fanconi type syndrome has been associated with the use of outdated or degraded tetracycline. Therefore, they should be stored, until their expiration date, away from UV light sources, moisture and in a sealed container. Nephrogenic diabetes insipidus has been reported in conjunction with administration of demethylchlortetracycline.
Vertigo	Reported with the use of minocycline.

Table 3. Side Effects and Toxicities (Continued)

Teratogenesis	The literature suggests that these agents are potential teratogens, and have resulted in malformed hands and limbs. Do not use in females in the childbearing age range who have missed one or more menstrual periods.
Skin	Photosensitivity (especially with demethylchlortetracycline), rash, oncholysis.

\* Adapted from Ciancio, S., 1976

Several reports have been published indicating that broad spectrum antibiotics, administered via the systemic route, may be effective in the treatment of periodontitis in man.<sup>6,7</sup> Animal experiments have further revealed that daily systemic tetracycline not only changes the plaque microbiota but also reduces signs of gingivitis<sup>6</sup> and markedly inhibits the progression of alveolar bone loss in dogs.<sup>11</sup> In the earlier literature, Stahl suggested beneficial effects of tetracycline in Long Evans strain rats showing early crestal bone repair following gingival injury.<sup>79,80</sup> Shaw, et al. indicated reversal of the periodontitis syndrome in rice rats after tetracycline therapy.<sup>81</sup>

Several recent studies have evaluated the effectiveness of short-term use of tetracycline in the treatment of periodontal disease. In one series of studies<sup>6,82</sup> tetracycline administered orally for two weeks was compared with thorough scaling and root planing (conventional therapy) in the treatment of advanced periodontal disease. The results indicated a definite change in the proportions of certain bacterial forms and an improvement of the clinical parameters assessing periodontal disease both in response to mechanical as well as chemical treatment. They also noted, however, that in the absence of mechanical debridement, tetracycline therapy merely had a transient effect.

In another study, the clinical and microbiological effects of adjunctive tetracycline were not decidedly different from the effects of thorough conventional treatment.<sup>83</sup> However, in this study, two patients who did not respond well to scaling did show significant improvement in

clinical parameters examined after a two-week course of the antibiotic.

In their study of juvenile periodontitis, Newman, Socransky, and Listgarten<sup>5</sup> were able to characterize the Gram-negative microorganism. The antibiotic sensitivity of these organisms was tested on the isolates and on the basis of these results the patients were treated with chlor-tetracycline in conjunction with local periodontal therapy.

Few studies in the literature report the effect of long term tetracycline therapy of periodontal diseases. In one recent study, Osterberg, et al.<sup>10</sup> found that the removal of a complex, predominantly asaccharolytic, anaerobic Gram-negative flora by the administration of tetracycline over a 30 day period (1000 mg/day) was correlated with improved clinical status as measured by decreased pocket depth as well as decreased gingival inflammation. In another recent study, Williams, et al.<sup>9</sup> suggested that long-term tetracycline therapy (250 mg/day) did not provide more protection against the establishment of flora associated with disease than would a two-week course of 1000 mg/day. In fact, some of the organisms currently thought important to the pathogenesis of periodontal disease were retained by the 250 mg/day treatment.

Significant numbers of resistant organisms have been found in a group of patients maintained on 250 mg/day of tetracycline for periods up to 121 days.<sup>9</sup> Most notable has been a significant increase in the proportions of resistant streptococci after such tetracycline therapy.<sup>9, 10,83</sup>

Some oral organisms develop multiple resistance to antibiotics via R-plasmid transfer after a protracted period of tetracycline therapy.<sup>9</sup>

Recent studies have shown that it is possible to place tetracycline directly into pockets and significantly change the composition of the subgingival flora of initially diseased sites.<sup>12,13</sup> This treatment entails filling hollow fibers with tetracycline. Such a system provides adequate drug therapy with less than a 1/1000 of the amount of tetracycline required for systemic therapy. This would result in a decreased incidence of side effects attributed to systemic tetracycline.

#### D. SAMPLE TAKING TECHNIQUES

In studying the microbiota of an site within the human oral cavity, one is faced with at least three significant problems. The first is the removal of the sample without contaminating it with microorganisms adjacent to the sample site. The second problem is the size the sample should be in order to be representative of the site under investigation. If the sample is too small, a spurious count of the relative percentage distribution of the microorganisms will be obtained. Conversely, the larger the sample the more likely one is to rule out differences which might exist from the depths of the pocket to the gingival crevice. The third problem is to recover, and culture, the specific inhabitants in the population of organisms at the site.

Several sampling techniques have been utilized to study the gingival crevice or periodontal pocket microbiota. Some investigators have stressed the importance of defining the microroganisms resident within the gingival sulcus or periodontal pocket, rather than those located at the gingival margin, and several sampling techniques have been devised to

avoid, or minimize, contamination from areas outside the gingival crevice or periodontal pocket.

Waerhaug and Steen (1952),<sup>84</sup> sterilized the tooth and gingival surface with equal volumes of glycerol and 5% iodine in ethanol prior to entering the crevice to collect material with a steel blade. Their investigation indicated that as a rule the gingival crevice, free from calculus or deposits, was sterile. Boyd and Rosenthal (1958),<sup>85</sup> exposed the sulcus using a sterile probe, and the sample was taken with a second sterile probe.

Gavin and Collins (1961),<sup>86</sup> placed a 5 mm. length of a 19 gauge hypodermic needle with a smooth 1 mm. bevel into the entrance of the sulcus. A sterile paper point was passed through the tube of the needle and was used to collect material from the depths of the gingival crevice. An absorbant paper point, rather than a metal instrument, was thought to collect a larger, and therefore, a more representative sample.

The results of the two latter studies showed that the clinically healthy gingival crevice was by no means sterile. These investigators (Gavin and Collins, 1961; Boyd and Rosenthal, 1958)<sup>85,86</sup> also used the above method of sampling following the application of an iodine glycerol mixture (Waerhaug and Steen, 1952).<sup>84</sup> They found that the application of iodine-glycerol mixture rendered the gingival crevice sterile, and concluded that the iodine-glycerol mixture penetrated into the crevice by capillary action. Castro and Going (1964),<sup>87</sup> used a method similar to Boyd and Rosenthal (1958),<sup>85</sup> with the difference that the sample was



collected not with a sterile probe, but with a sterile paper point.

Wilkinson (1962),<sup>88</sup> "sterilized" the outer surface of the gingiva, and then pierced it with a syringe needle. The fluid content was aspirated after injecting a minimal amount of saline. An excess of saline, however, could cause contamination of the sample from the gingival margin, especially in a shallow pocket.

Apparently contamination of the crevice using the above methods continued to be a problem. Therefore, antiseptics were again applied, but with modifications to overcome some of the difficulties encountered previously by Waerhaug (1952).<sup>84</sup> Bervell (1968),<sup>89</sup> applied an iodine varnish to the tooth and gingival margin. The varnish dried and formed a membrane which could be pierced, permitting samples to be removed by means of a small platinum loop.<sup>90</sup> Kelstrup (1971),<sup>90</sup> revealed by in vitro testing,<sup>89</sup> that the iodine varnish described by Bervell (1968), diffused readily into narrow, water-filled spaces. He postulated that such a varnish might penetrate the gingival sulcus, because ethanol, which was used as a solvent, was easily miscible with water. He, therefore, suggested the use of an improved iodine varnish with ether as a solvent. The sample was taken with a short absorbant paper point after piercing the membrane covering of the sulcus with a sterile probe.

As a means to prevent contamination of the sample in deep periodontal pockets, Slots (1975),<sup>91</sup> developed a technique in which a full thickness flap was raised from an incision, placed 1 cm apically to the pocket base and reflected in a coronal direction. After exposure, a

sample of the bacteria was obtained by means of a small sterile curette or paper point. Although effective, this technique was impractical since a surgical procedure was required for every sample.

Listgarten and Hellden (1978),<sup>72</sup> obtained subgingival bacterial samples by means of a sterile periodontal curette, after supragingival plaque had been removed. This proved to be a simple but popular technique among other researchers. A drawback to this technique did exist, however, since the curette sampled mainly adherent plaque in certain areas of the root and thus was difficult to standardize.

Slots, et al. (1979),<sup>83</sup> utilized paper points to sample pockets after supragingival deposits were removed from the isolated teeth. The authors felt that this technique allowed for standardization of the microbial flora from the entire pocket.

#### E. RATIONALE

The current investigation was designed to examine several aspects of juvenile periodontitis. First, the quantitative composition of subgingival microbial plaque expressed in the percentage of anaerobic bacteria and facultative bacteria to the total flora was determined from deep pockets of selected teeth. Secondly, shifts in these percentages were observed for a five month period following conventional treatment consisting of scaling and root planing or after localized treatment with tetracycline via the hollow fibers described by Goodson and coworkers.<sup>12</sup>

The sampling technique chosen was similar to the techniques of Slots and coworkers,<sup>83</sup> utilizing sterile paper points. This technique

allowed for standardization and assessment of the flora from the entire pocket.

This investigation also employed conventional culturing techniques utilizing thioglycollate broth as the transport media and incubation in anaerobic jars (BBL) flushed and sustained with a gaseous anaerobic mixture creating an immediate anaerobic environment. The anaerobic environment was monitored by oxygen sensitive indicators.

## CHAPTER III

### MATERIALS AND METHODS

A. Selection of Patients: Juvenile periodontitis patients were defined as otherwise healthy young individuals with at least 7 mm loss of attachment as measured from the cemento-enamel junction on more than one tooth. Four such individuals were available for the study; all females ranging between the ages of 16-23. None of the subjects had antibiotic therapy or scaling within the last 6 months. Informed consent was obtained from each subject or from the parents of minors (see Fig. 1). Systemic health was monitored prior to therapy by the sequential multiple analyses 20 series and complete blood count. All values were within normal ranges for all subjects. None of the women were pregnant. Because of the localized nature of this disease, an attempt was made to select contralateral, periodontically-involved first molars in each subject where pockets could be probed from 6 to 10 mm. In each patient, one tooth was selected to be treated by conventional therapy, i.e. scaling and root planing while the other to be treated with tetracycline-filled hollow fiber.

B. Clinical Protocol: For all subjects, clinical and microbiological monitoring was carried out twice prior to treatment (which was begun at day 0) and after therapy at intervals of 2,4,12, and 20 weeks. Standardized radiographs were taken prior to therapy. A description of each subject and the periodontal pockets chosen for study are given in Table 4.



Table 4. Description of Patients and Sites Selected For Study

Patient	Age	Periodontal Probing		Radiographic appearance		GI	PI	Therapy
		Pocket Site	Depth (mm)	H/V $\Delta$	% loss			
DZ	23	19M**	8	V	30	1.33	1.00	Scaling and root planing
		30D	8	V	75	1.33	1.50	TTC-hollow fiber
KL	21	19D	10	V/H	75	2.25	1.33	TTC-hollow fiber
		30D	10	V/H	75	1.33	1.17	Scaling and root planing
LL	16	19D	10	V	75	1.42	1.50	Scaling and root planing
		30D	9	V	75	1.67	1.50	TTC-hollow fiber
SB	16	#19M	10	V/H	75	1.90	1.50	TTC-hollow fiber
		#10D	6	V	50	1.36	0.92	Scaling and root planing

\* All subjects were Caucasian females with a diagnosis of localized juvenile periodontitis

$\Delta$  H refers to horizontal bone loss, V to vertical bone loss

\*\* M refers to mesial, D to distal

The following therapeutic regime was instituted for each patient: Prior to day 0, oral hygiene instructions was provided and two bacterial samples from each site, sampled one week apart, were taken to provide a baseline of the subgingival microflora. At day 0, the therapeutic procedures listed on Table 4 were performed on the selected teeth. Scaling and root planing were accomplished under local anesthesia. The hollow fibers filled with tetracycline were inserted without anesthesia.

C. Procedure used for Filling Hollow Fibers: Controlled delivery devices were prepared by filling commercially available bio-compatible cellulose acetate hollow fibers (Cuprothane) with tetracycline. The hollow fibers had an outside diameter of 250  $\mu$ m, and inside diameter of 200  $\mu$ m and a wall thickness of 25  $\mu$ m. (Fig. 2).<sup>12</sup>

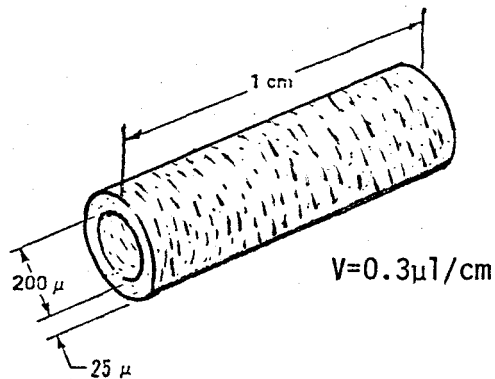

Fig. 2. Dimensions of Cellulose Acetate Hollow Fibers used for Drug Delivery to the Periodontal Environment. (Adapted from Goodson, et al. 1979)

These fibers were manufactured and marketed for hollow fiber dialysis by Baxter/Travenol Laboratories Incorporated (Deerfield, Ill.). The fibers were available in a wide range of permeability from nominal molecular weight cut-off values of 200 to 50,000 daltons when used for dialysis. The 200 dalton material was chosen since previous studies utilized this size for proper diffusion of the tetracycline.<sup>12,13</sup>

The tetracycline hydrochloride used to fill the hollow fibers was obtained from Lederle under the trade name of Achromycin.\* One and one-half ml distilled water was injected into the ampule containing the crystalline drug, aspirating and reinjection of the contents to facilitate dissolution of the drug. The ampule was sonicated for 10 minutes to enhance complete dissolution. This saturated solution was then aspirated into a 3 cc syring and the hypodermic needle removed.

The hollow fibers were prepared for loading by placing them separately into the lumen of a sterile 26 gauge hypodermic needle that was attached to a low-vacuum saliva ejector. The fibers were allowed to stand in the vacuum for several minutes to minimize the moisture content within the fiber. After this time, the free end of the fiber was placed into the lumen of the 3 cc syringe containing the saturated Achromycin solution. After 30 seconds, the fiber was filled with the tetracycline solution. Care was taken not to introduce bubbles into the fiber and a

\* Achromycin<sup>R</sup>, Tetracycline Hydrochloride, Intramuscular 250 mg Vial, Lederle Laboratories Division, American Cyanamid Company, Pearl River, N.Y.



solid yellow color of the fiber indicated proper filling. The filled fibers were then suspended into a U-shaped fashion allowing gravity and capillary action to concentrate the solution in the center of the fiber. The fibers were now ready to be inserted into the pockets of the selected sites. Recent studies utilizing tetracycline in these hollow fibers have shown that  $340 \mu\text{g}/\text{cm}$  of the drug could be loaded. <sup>12</sup> Approximately 15 mm of drug-filled hollow fiber material containing approximately  $450 \mu\text{g}$  of <sup>12</sup> Achromycin was placed in the bottom of the pocket.

Drug-filled fibers were used in therapy by tying them around the cervix of teeth to be treated and gently pressing into the periodontal pocket. (Fig. 3) The relative size of these fibers can be appreciated

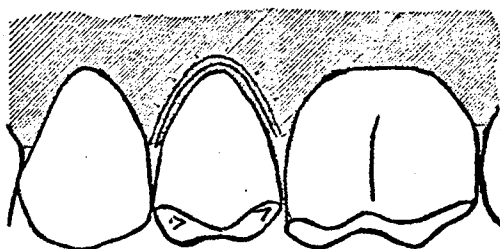

Fig. 3. Placement of Drug-filled Hollow Fibers for Local Treatment of Periodontal Disease. Single strands of tetracycline-filled hollow fibers are palced around the tooth and gently pressed below the margin of the gingiva. (Adapted from Goodson, et al., 1979).

by considering that they are 30% smaller than the tip of a commonly used periodontal probe. The fibers were left in place for a 24 hour period

and then removed. The absence of the yellow color within the fiber indicated that the tetracycline had been displaced.<sup>12</sup>

D. Clinical Measurements: The gingival condition was determined by the Gingival Index of L oe and Silness<sup>92</sup> and the oral hygiene status was determined by the Plaque Index of Silness and L oe.<sup>93</sup> Table 5 and 6 gives the criteria for each index system. A score of 0-3 is given to the buccal, mesial/distal, and lingual surfaces of the tooth and then averaged. The degree of inflammation or plaque accumulation is then determined from Table 7. Periodontal pocket depth was measured with a calibrated Michigan Probe with markings at each millimeter except the fourth and sixth millimeter. The probable depth was measured to the nearest millimeter and always at the same site at each tooth.

E. Microbiological procedures: The subgingival microflora was monitored by culture examination. Microbiological samples were collected from the two test sites per patient by the following procedure: supra-gingival deposits were removed from the isolated teeth with a sterile cotton ball, and one paper point (Johnson Coarse, Johnson & Johnson) was subsequently inserted into the pocket until resistance was met or the paper point bent. The paper point was kept in place for 10 seconds and then transferred immediately to 1.0 ml of anaerobically stored 3% thioglycolate broth (BBL).

Processing of the plaque samples was initiated within 10 to 15 minutes of collection by displacing the bacterial deposits from the paper point and dispersing the suspension by vortex mixing for 60 seconds.

Table 5. Criteria for the Gingival Index\*

Score	Description
0	- Absence of inflammation
1	- Mild inflammation; slight change in color and little change in texture.
2	- Moderate inflammation; moderate glazing, redness, edema, and hypertrophy. Bleeding on pressure.
3	- Severe inflammation; marked redness and hypertrophy. Tendency to spontaneous bleeding. Ulceration.

\* Adapted from Loe, H. and Silness, J., 1963

Table 6. Criteria for the Plaque Index\*

Score	Description
0	- No plaque
1	- A film of plaque adhering to the free gingival margin and adjacent areas of the tooth. The plaque may be seen in situ only after the application of disclosing solution or by using the probe on the tooth surface.
2	- Moderate accumulation of soft deposits within the gingival pocket or on the tooth and gingival margin which can be seen by naked eye.
3	- Abundance of soft matter within the gingival pocket and/or on the tooth and gingival margin.

---

\* Adapted from Silness, J. and Loe, H., 1964

Table 7. Correlation of Mouth Scores to Degree\*  
of Inflammation and Plaque Accumulation

Mouth Scores (GI or PI)	Description
0.1 - 1.0	Mild inflammation or plaque accumulation
1.1 - 2.0	Moderate inflammation or plaque accumulation
2.1 - 3.0	Severe inflammation or plaque accumulation

\* Adapted from Silness, J. and Loe, H., 1964

After vortexing, the bacterial suspension was serially diluted in 10-fold steps in anaerobically-stored dilution blanks. The bacterial sample was plated on the growth media at three dilutions ( $10^{-3}$ ,  $10^{-4}$ , and  $10^{-5}$ ) by plating aliquots of 0.1 ml of the appropriate dilutions on the growth media by use of sterile bent glass rods.

The growth media utilized for primary isolation was prepared by combining 3% Todd Hewitt broth (BBL), 0.5% Yeast extract (BBL), and 1.5% granulated agar (BBL). After autoclaving, the growth media was allowed to rest in a water bath at 60°C for 1 hour and then supplemented with 5% defrinated sheep blood (Ovine Laboratories, Chicago), 5.0 µg of hemin per ml (Sigma Chemical Co., Missouri), and 0.5 µg of menadione per ml (Sigma Chemical Co., Missouri). Other growth media was further supplemented with 1.0 µg per ml of tetracycline hydrochloride (Sigma Chemical Co., Missouri). The blood agar plates were freshly prepared and stored for approximately 24 hours in the anaerobic chamber prior to plating.

Three series of duplicate plates at the three dilutions were prepared for each sample. In one of the series, the growth media had been supplemented with 1.0 µg/ml tetracycline hydrochloride. These plates along with another series of inoculated plates were incubated anaerobically at 37°C for 4 to 6 days in a Gas Pak jar (BBL). The anaerobic environment was produced by the evacuation-replacement method. This method produced an immediate anaerobic environment by flushing the chamber with a mixture of gas containing 5% carbon dioxide, 10% hydrogen and 85% nitrogen (Union Carbide, New York). The anaerobic environment was

monitored with oxygen-sensitive indicator strips (BBL). The third series of plates was incubated aerobically at 37° C for 4 days. A total of eighteen plates therefore was required for each sample. After the 4 to 6 day incubation period, viable counts were recorded from plates that exhibited between 30 and 300 colonies. These colonies were recorded on a counting chamber using transmitted light and a stereoscopic microscope.

## CHAPTER IV

### RESULTS

As described in Table 4, four patients with juvenile periodontitis were included in this study. Pocket depth ranged from 6 to 10 mm with generally 75% loss of alveolar bony support. This loss tended to be localized in the mandibular first molar area and anterior teeth, however, generalized bone loss was noted in patient KL. All patients exhibited gingival inflammation. At the point in therapy at which the plaque samples were taken, the degree of gingival inflammation at the sampling site could not be related to the pocket depth or to the general periodontal breakdown. In one patient, SB, a maxillary lateral incisor and a mandibular first molar were selected for treatment due to the lack of contralaterally-similar periodontically-involved mandibular first molars.

#### Clinical Parameters

The effect of scaling and root planing on the Gingival Index scores is shown in Table 8. The mean GI scores and standard deviations are presented for each patient over a 20-week period. A significant drop of the GI score ( $P < 0.001$ ) was apparent for all patients two weeks following treatment. The mean GI score at Day 0 was 1.36. Two weeks following treatment, this value decreased to 0.74 indicating a change from moderate to mild inflammation according to Table 7. After this two week period the scores increased continually with some variation, throughout the



TABLE 8 - GINGIVAL INDEX SCORES OVER A 20 WEEK PERIOD OF SELECTED TEETH IN 4 JUVENILE PERIODONTITIS PATIENTS TREATED BY A SINGLE COURSE OF SCALING AND ROOT PLANING.

Subject	Day 0*	Week 2	Week 4	Week 12	Week 20
DZ	1.33	0.67	1.00	1.00	0.67
KL	1.33	1.03	1.17	0.87	1.00
LL	1.42	0.67	1.00	1.33	1.33
SB	1.36	0.58	0.67	1.10	1.26
$\bar{X}$	1.36	0.74	0.96	1.08	1.07
S.D.	±.04	±0.17	±0.18	±0.17	±0.26
		P<0.001	P<0.04	P<0.03	P>0.05

\* = mean of two scores taken at a one week intervals

$\bar{X}$  = mean

S.D. = standard deviation

P = probability; compared to Day 0

20-week period but never reached the pretreatment values. At week 20 the mean GI score was 1.07 which was not significantly different from pretreatment values.

Table 9 illustrates the effect of scaling and root planing on Plaque Index scores over the 20-week period. In all patients, a significant drop in the scores ( $P < 0.001$ ) occurred two weeks following treatment. The plaque accumulation in these patients at day 0 ranged from mild to moderate (Table 7) and did not correlate well to the degree of periodontal pathology. After the drop in all the scores two weeks following treatment, the scores tended to continually increase throughout the 20-week period. With the exception of DZ, the PI scores at the week-20 period were lower than at pretreatment values.

Probing depth measurements in teeth treated by scaling and root planing are shown in Table 10. At week 2, similar to the results of the PI and GI scores, a significant ( $P < 0.003$ ) improvement in the periodontal health of the tooth was noted, i.e. pockets depths generally decrease 2 to 3 mm following treatment. By week 20, however, the pocket depths had returned (patient KL and SB) or nearly returned (patient DZ and LL) to pretreatment levels. The relatively large standard deviation could be explained in part due to patient SB in which a maxillary lateral incisor was used rather than a mandibular first molar. Unlike the other patients, SB did not have contralateral mandibular first molars with similar periodontal involvement, thus the maxillary lateral incisor with less periodontal breakdown compared to the molars was chosen. A similar

TABLE 9 - PLAQUE INDEX SCORES OVER A 20 WEEK PERIOD OF SELECTED TEETH IN 4 JUVENILE PERIODONTITIS PATIENTS TREATED BY A SINGLE COURSE OF SCALING AND ROOT PLANING.

Subject	Day 0*	Week 2	Week 4	Week 12	Week 20
DZ	1.00	0.67	1.17	1.00	1.13
KL	1.17	0.67	1.00	1.00	1.00
LL	1.50	1.00	1.13	1.33	1.36
SB	0.92	0.50	0.33	0.67	0.87
$\bar{X}$	1.15	0.71	0.91	1.00	1.09
S.D.	$\pm 0.35$	$\pm 0.18$	$\pm 0.34$	$\pm 0.23$	$\pm 0.18$
		P<0.001	P>0.05	P>0.05	P>0.05

\* = mean of two scores taken at a wone week intervals  
 $\bar{X}$  = mean  
 S.D.= standard deviation  
 P = probability, compared to Day 0

TABLE 10 - POCKET DEPTH RECORDING OVER A 20 WEEK PERIOD OF SELECTED TEETH IN 4 JUVENILE PERIODONTITIS PATIENTS TREATED BY A SINGLE COURSE OF SCALING AND ROOT PLANING.

Subjects	Day 0*	Week 2	Week 4	Week 12	Week 20
DZ	8.0	6.0	7.0	7.0	7.0
KL	10	7.0	7.0	9.0	10.0
LL	10	7.0	7.0	8.0	9.0
SB	6.0	4.0	5.0	5.0	6.0
$\bar{X}$	8.5	6.0	6.5	7.3	8.0
S.D.	$\pm 1.7$	$\pm 1.2$	$\pm 0.9$	$\pm 1.5$	$\pm 1.6$
		P<0.003	P<0.04	P<0.02	P>0.05

\* = mean of two recordings taken at one week interval

$\bar{X}$  = mean

S.D. = standard deviation

P = probability; compared to Day 0

trend in the pocket depth over the 20 week period, however, was noted in this patient.

The effect of local tetracycline therapy on the Gingival and Plaque Index scores are presented in Tables 11 and 12. In both tables, a significant reduction of the scores ( $P < 0.01$ ) was seen 2 weeks after treatment. After this period, the GI and PI scores began to increase steadily and at week 20 the scores were not significantly different from pretreatment levels.

Table 13 illustrates pocket depth measurements in teeth treated with localized tetracycline. The results are strikingly similar to Table 10. The pockets were significantly ( $P < 0.007$ ) reduced 2 weeks after therapy. This effect was transient and at the conclusion of the experiment pocket depth measurements had nearly returned to pretreatment levels.

#### Microbiological Parameters

The bacterial composition of the pretreatment plaque samples, illustrated in Table 14, showed a predominance in anaerobic bacteria (75%) compared to the facultatively anaerobic and aerobic bacteria (25%). As seen in the microbial data presented in Table 14, there was good agreement in the proportions of flora designated as anaerobic, facultative, and tetracycline-resistant bacteria from the two pretreatment plaque samples. Table 15 illustrates the relative distribution of microorganism in the subgingival plaque of a healthy individual, employing similar sampling and culturing techniques. The results showed that 63% of the microflora consisted of facultative bacteria, while 37% of the flora consisted of

TABLE 11 - GINGIVAL INDEX SCORES OVER A 20 WEEK PERIOD OF SELECTED TEETH IN 4 JUVENILE PERIODONTITIS PATIENTS TREATED BY LOCAL TETRACYCLINE THERAPY.

Subject	Day 0*	Week 2	Week 4	Week 12	Week 20
DZ	1.33	0.67	1.00	1.10	1.28
KL	2.25	1.03	1.47	1.80	1.90
LL	1.67	0.83	1.16	1.10	1.12
SB	1.90	1.00	1.33	1.46	1.80
$\bar{X}$	1.78	0.88	1.24	1.37	1.53
S.D.	±0.36	±0.15	±0.18	±0.29	±0.33
		P<0.004	P<0.01	P<0.01	P>0.05

\* mean of two scores taken at one week intervals

$\bar{X}$  = mean

S.D. = standard deviation

P = probability; compare to Day 0

TABLE 12 - PLAQUE INDEX SCORES OVER A 20 WEEK PERIOD OF SELECTED TEETH IN 4 JUVENILE PERIODONTITIS PATIENTS TREATED BY LOCAL TETRACYCLINE THERAPY.

Subject	Day 0*	Week 2	Week 4	Week 12	Week 20
DZ	1.50	0.67	1.33	1.00	1.00
KL	1.33	1.00	1.33	1.33	1.23
LL	1.50	1.00	1.16	1.20	1.36
SB	1.50	0.83	1.16	1.67	1.67
$\bar{X}$	1.46	0.88	1.25	1.30	1.32
S.D.	±0.07	±0.14	±0.08	±0.24	±0.24
		P<0.01	P>0.05	P>0.05	P>0.05

\* mean of two scores taken at one week intervals

$\bar{X}$  = mean

S.D. = standard deviation

P = probability; compared to Day 0

TABLE 13 - POCKET DEPTH RECORDINGS OVER A 20 WEEK PERIOD OF SELECTED TEETH IN 4 JUVENILE PERIODONTITIS PATIENTS TREATED BY LOCAL TETRACYCLINE THERAPY.

Subject	Day 0*	Week 2	Week 4	Week 12	Week 20
DZ	8.0	6.0	6.0	6.0	7.0
KL	10	8.5	9.0	9.0	10
LL	10	8.0	8.0	9.0	9.0
SB	10	7.0	8.0	9.0	9.0
$\bar{X}$	9.5	7.4	7.8	8.3	8.8
S.D.	$\pm 0.9$	$\pm 1.0$	$\pm 1.1$	$\pm 1.3$	$\pm 1.1$
		P<0.007	P<0.006	P<0.02	P>0.05

\* mean of recordings taken at one week intervals

$\bar{X}$  = mean

S.D. = standard deviation

P = probability; compared to Day 0

TABLE 14 - DISTRIBUTION OF SUBGINGIVAL MICROFLORA IN 4 JUVENILE PERIODONTITIS PATIENTS. BASELINE VALUES OBTAINED FROM TWO SITES WITHIN EACH SUBJECT AT A ONE WEEK INTERVAL. (PERCENTAGE)

Subject	Site	Anaerobes		Facultative		Tetracycline resistant	
		#1	#2	#1	#2	#1	#2
DZ	Sample 1	79	72	22	28	0.4	17
	Sample 2	80	88	20	20	0.3	11
KL	Sample 1	84	73	16	27	9.3	5.0
	Sample 2	74	83	26	17	28	11
LL	Sample 1	72	71	28	29	6.1	11
	Sample 2	70	77	30	23	16	12
SB	Sample 1	62	77	38	23	20	32
	Sample 2	60	79	40	21	18	33
$\bar{X}$		75		25		14.4	
S.D.		±6.6		±6.6		±9.8	

± = Mean

S.D.= Standard Deviation

TABLE 15 - DISTRIBUTION OF THE SUBGINGIVAL MICROFLORA IN A HEALTHY PATIENT. (MEAN PERCENT)

sample	Anaerobic	Facultative	Tetracycline-Resistant
#1	33	67	8
#2	41	59	15
$\bar{X}$	37	63	12



anaerobic bacteria.

Tables 16-19 presents the results from the microbiological examination of the treated sites over the 20-week period. It is obvious that the different treatment procedures had a marked influence on the relative distribution of microorganisms of the subgingival plaque.

Tables 16 and 17 illustrated the effect of scaling and root planing on the percentage of anaerobic and facultative microorganisms in the subgingival plaque over a 20 week period. Two weeks following treatment, a significant decrease ( $P < 0.02$ ) in the percentage of anaerobic microorganisms concomitant with an increase in the facultative microorganisms was seen. The mean value of anaerobic microorganism dropped from approximately 73% at day 0 to approximately 33% at week 2. Following this period a trend to return to pretreatment values occurred with increasing acceleration especially between week 4 and 12. In all patients, except DZ, the recordings of anaerobic microorganisms at week 20 had surpassed pretreatment values.

Tables 18 and 19 illustrate the effect of local tetracycline therapy on the subgingival microflora. Similar to the scaling and root planing results, a significant decrease ( $P < 0.003$ ) in the percentage of anaerobic microorganisms concomitant with an increase in the percentage of facultative microorganisms was seen two weeks following treatment. The mean value of anaerobic microorganism decrease from approximately 78% at day 0 to 30% at week 2. Following this period, anaerobic microorganism increased steadily throughout the 20 week period, with the

TABLE 16 - PERCENTAGE OF ANAEROBIC BACTERIA OVER A 20 WEEK PERIOD  
IN THE POCKETS OF 4 JUVENILE PERIODONTITIS PATIENTS  
TREATED BY A SINGLE COURSE OF SCALING AND ROOT PLANING.

Subject	Day 0*	Week 2	Week 4	Week 12	Week 20
DZ	80	35	33	48	54
KL	78	16	44	80	90
LL	71	41	55	63	73
SB	61	40	50	67	70
$\bar{X}$	73	33	46	65	72
S.D.	$\pm 7.4$	$\pm 10$	$\pm 8.2$	$\pm 11$	$\pm 13$
		P<0.02	P<0.05	P>0.05	P>0.05

\* mean of 2 samples taken at a one week interval

$\bar{X}$  = mean

S.D.= standard deviation

P = probability; compared to Day 0

TABLE 17 - PERCENTAGE OF FACULTATIVE BACTERIA OVER A 20 WEEK PERIOD  
IN THE POCKETS OF 4 JUVENILE PERIODONTITIS PATIENTS  
TREATED BY A SINGLE COURSE OF SCALING AND ROOT PLANING.

Subject	Day 0*	Week 2	Week 4	Week 12	Week 20
DZ	20	65	67	52	46
KL	22	84	56	20	10
LL	29	59	45	37	27
SB	39	60	50	33	30
$\bar{X}$	27	67	54	35	28
S.D.	$\pm 7.4$	$\pm 10$	$\pm 8.2$	$\pm 11$	$\pm 13$

\* mean of 2 samples taken at a one week interval

$\bar{X}$  = mean

S.D.= standard deviation

TABLE 18 - THE PERCENTAGE OF ANAEROBIC BACTERIA OVER A 20 WEEK PERIOD IN THE POCKETS OF 4 JUVENILE PERIODONTITIS PATIENTS TREATED BY LOCAL TETRACYCLINE THERAPY.

Subject	Day 0*	Week 2	Week 4	Week 12	Week 20
DZ	80	35	38	47	53
KL	78	19	36	70	76
LL	74	26	37	49	77
SB	78	43	58	87	78
$\bar{X}$	78	30	43	63	71
S.D.	±2.2	±9.1	±9.2	±16	±10
		P<0.003	P<0.007	P>0.05	P>0.05

\* mean of two samples taken at 1 week intervals

$\bar{X}$  = mean

S.D. = standard deviation

P = probability; compared to Day 0

TABLE 19 - THE PERCENTAGE OF FACULTATIVE BACTERIA OVER A 20 WEEK PERIOD IN THE POCKETS OF 4 JUVENILE PERIODONTITIS PATIENTS TREATED BY LOCAL TETRACYCLINE THERAPY.

Subject	Day 0*	Week 2	Week 4	Week 12	Week 20
DZ	20	65	62	53	47
KL	22	81	64	30	24
LL	26	74	63	51	23
SB	22	57	42	13	22
$\bar{X}$	22	70	57	37	29
S.D.	±2.2	±9.1	±9.2	±16	±10

\* mean of two samples taken at 1 week intervals

$\bar{X}$  = mean

S.D. = standard deviation

greatest acceleration between week 4 and week 12. By week 20, the percentage of anaerobic microorganisms had returned to pretreatment values except for patient DZ who still had only 53% anaerobic microorganisms compared to a pretreatment value of 80%.

Tables 20 and 21 show the percentage of tetracycline-resistant bacteria of the subgingival plaque following scaling/root planing and local tetracycline therapy. All four patients harbored resistant microorganisms to 1.0 µg/ml tetracycline. The recordings were highly variable with respect to the patient from which they were isolated. With the tetracycline treated teeth, the resistant microorganisms rose sharply 2 weeks following treatment and then decreased sharply to below pretreatment values at week 20. The results from the scaled and root planed teeth are more variable but tend to show a gradual increase in the resistant microorganisms until week 12 with a subsequent decrease at week 20.

Figures 4-7 were constructed for each patient to help illustrate the change in the clinical and microbiological parameters over the 20-week experimental period. In each instance, Graphs A and B show the results from teeth treated with local tetracycline therapy and Graphs C and D show results from teeth treated by scaling and root planing. The dramatic change in the parameters that occurs at week 2 is well illustrated in all the figures.

Figures 8 and 9 are composites of all the patients illustrating the effect of scaling and root planing or local tetracycline therapy on the clinical and microbiological parameters. It appears from these figures,

TABLE 20 - PERCENTAGE OF TETRACYCLINE-RESISTANT BACTERIA OVER A 20 WEEK PERIOD IN THE POCKETS OF 4 JUVENILE PERIODONTITIS PATIENTS TREATED BY A SINGLE COURSE OF SCALING AND ROOT PLANING.

Subject	Day 0*	Week 2	Week 4	Week 12	Week 20
DZ	0.4	7.0	17	19	6.9
KL	7.8	20	19	18	18
LL	11	17	23	23	7.9
SB	19	34	40	41	40
$\bar{X}$	9.6	20	25	25	18
S.D.	$\pm 7.2$	$\pm 9.7$	$\pm 9.1$	$\pm 9.3$	$\pm 13$

\* mean of two samples taken at 1 week intervals  
 $\bar{X}$  = mean  
 S.D. = standard deviation

TABLE 21 - THE PERCENTAGE OF TETRACYCLINE-RESISTANT BACTERIA OVER A 20 WEEK PERIOD IN THE POCKETS OF 4 JUVENILE PERIODONTITIS PATIENTS TREATED BY LOCAL TETRACYCLINE THERAPY.

Subject	Day 0*	Week 2	Week 4	Week 12	Week 20
DZ	27	64	37	36	26
KL	19	55	24	16	19
LL	23	44	27	14	10
SB	32	61	11	13	21
$\bar{X}$	25	56	25	20	19
S.D.	$\pm 4.8$	$\pm 7.7$	$\pm 9.3$	$\pm 9.4$	$\pm 5.8$

\* mean of two samples taken at 1 week intervals  
 $\bar{X}$  = mean  
 S.D. = standard deviation

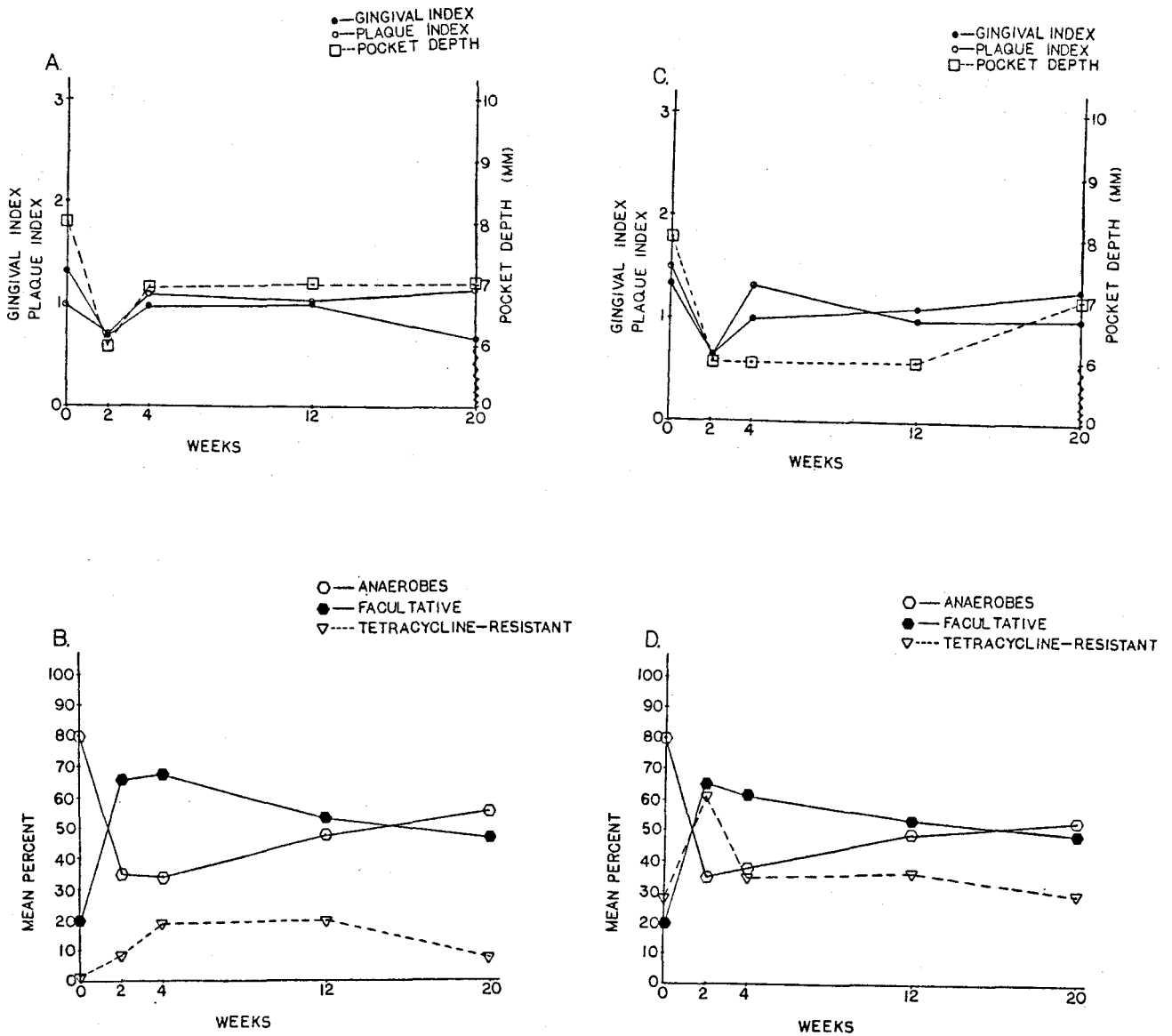

Figure 4. Patient DZ. Comparison of the effect of two treatments on the subgingival microflora and various clinical parameters over a 20-week period. A. and B.: tooth treated by local tetracycline therapy. C. and D.: tooth treated by scaling and root planing. Treatment at Day 0.

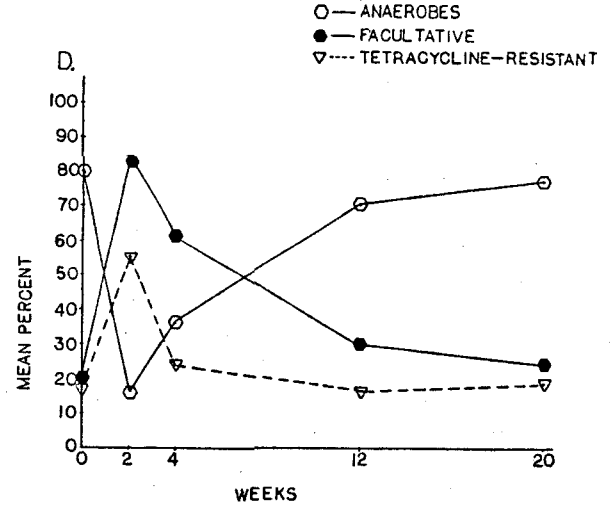
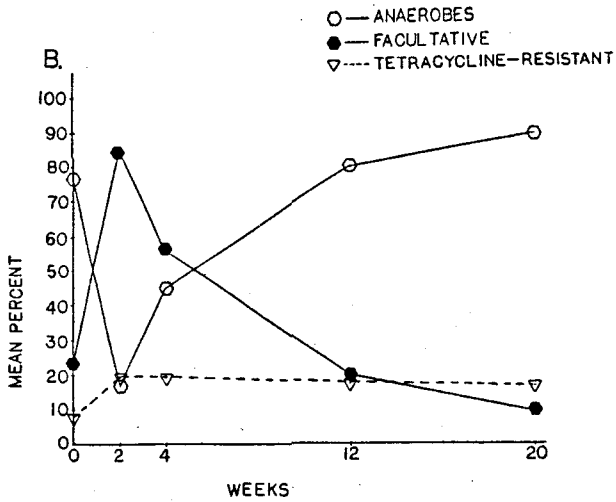
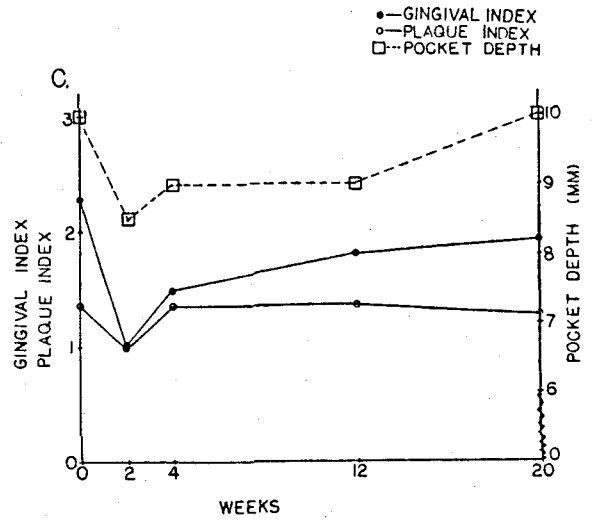
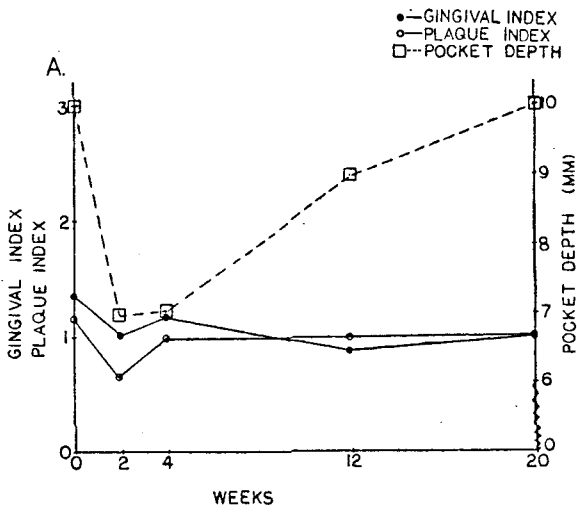

Figure 5. Patient KL. Comparison of the effect of two treatments on the subgingival microflora and various clinical parameters over a 20-week period. A and B: tooth treated by local tetracycline therapy. C and D: tooth treated by scaling and root planing. Treatment at Day 0.

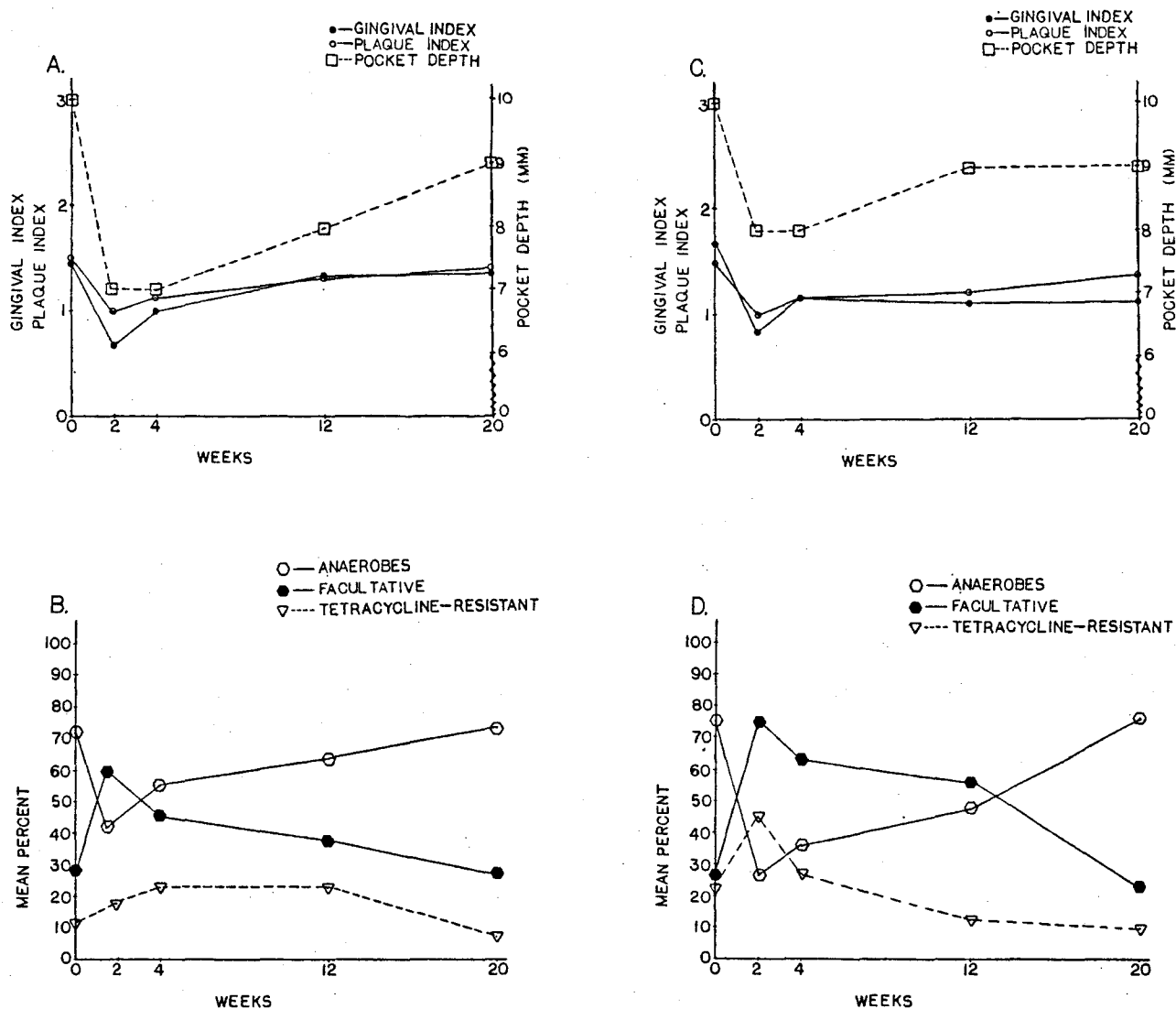

Figure 6. Patient LL. Comparison of the effect of two treatments on the subgingival microflora and various clinical parameters over a 20-week period. A and B: tooth treated by local tetracycline therapy. C and D: tooth treated by scaling and root planing. Treatment at Day 0.



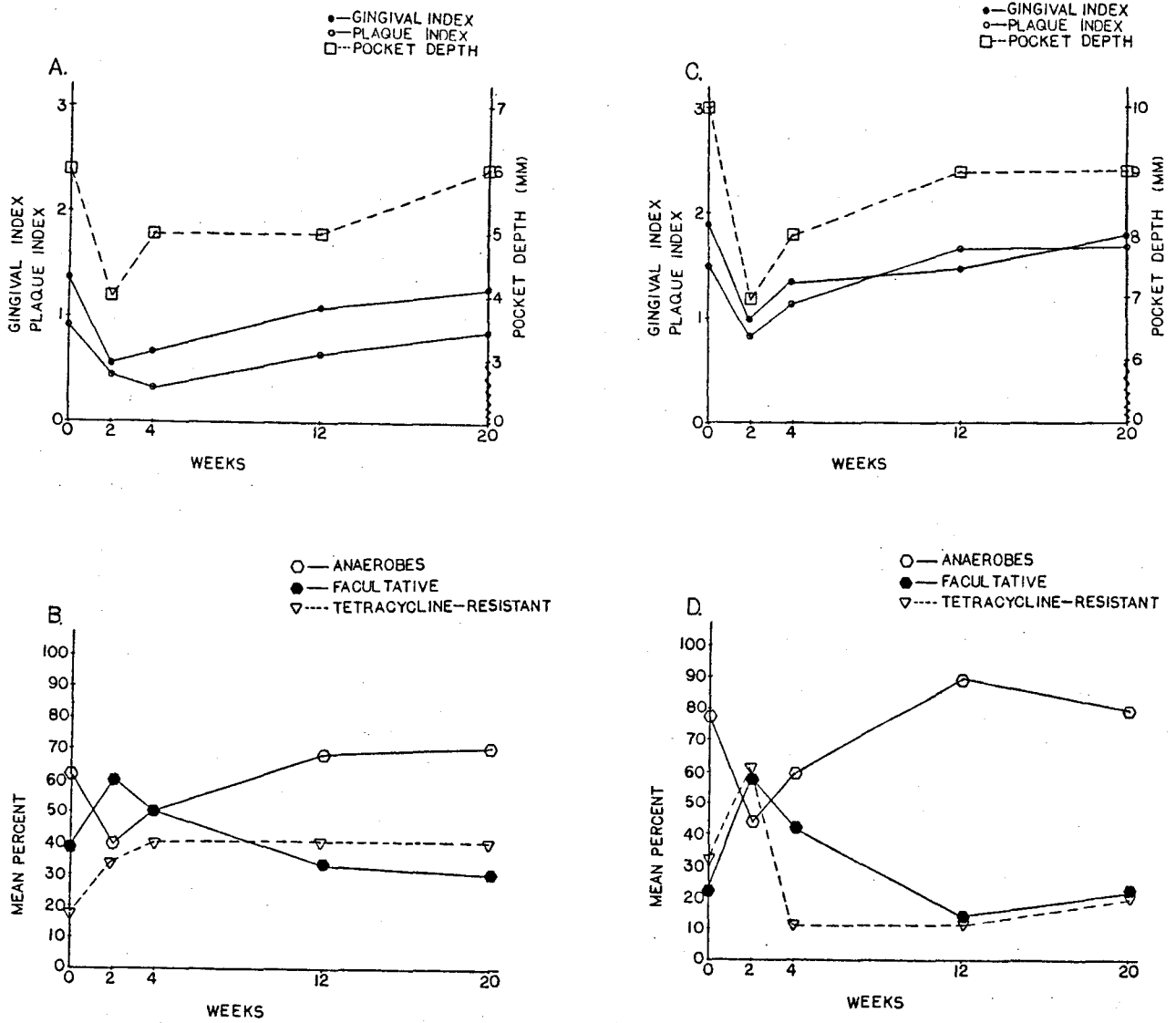

Figure 7. Patient SB. Comparison of the effect of two treatments on the subgingival microflora and various clinical parameters over a 20-week period. A and B: tooth treated by local tetracycline therapy. C and D: tooth treated by scaling and root planing. Treatment at Day 0.

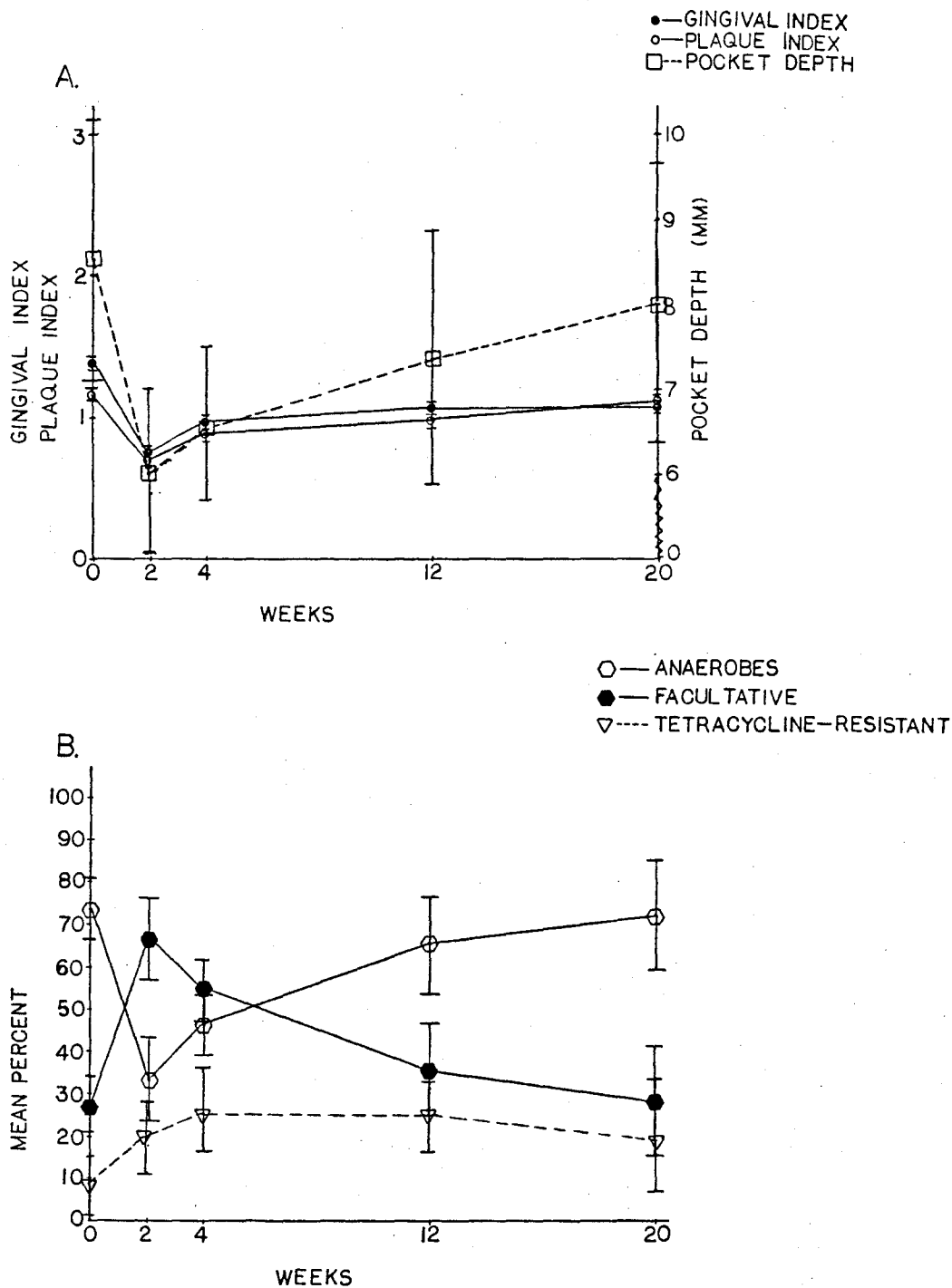

Figure 8. Composite graph of patients DZ, KL, LL and SB. Comparison of the effect of scaling and root planing on the subgingival microflora (B) and various clinical parameters (A) over a 20-week period. Treatment at Day 0.

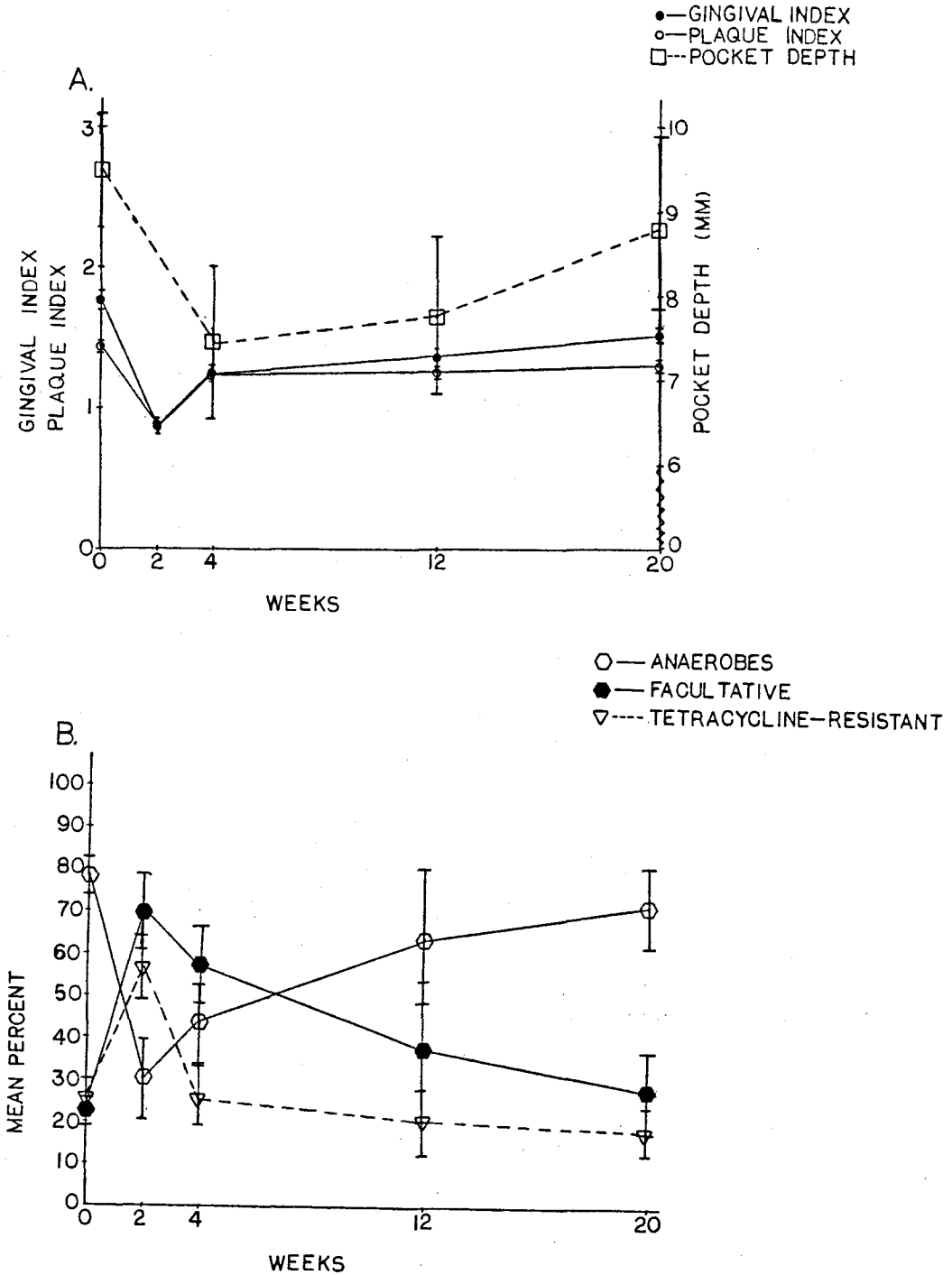

Figure 9. Composite graph of patients DZ, KL, LL and SB. Comparison of the effect of local tetracycline therapy on the subgingival microflora (B) and various clinical parameters (A) over a 20-week period. Treatment at Day 0.

that the improved clinical parameters was correlated with a shift in the subgingival microflora to a greater percentage of facultative organisms.

#### Statistical Analysis

Statistical analysis was determined by using the paired T-test at a level of significance set at 0.05.

## CHAPTER V

### DISCUSSION

Currently there remains some controversy over the exact role of bacteria in the pathogenesis of periodontal disease. It is unclear as to whether the effect of microorganisms is non-specific and dependent primarily on the mass of bacteria rather than the composition of the flora, or whether qualitative differences exist between a so-called pathogenic and non-pathogenic flora.<sup>94</sup>

Presently, many researchers are attempting to resolve this controversy. Unfortunately, despite significant advances in cultural techniques, particularly of strict anaerobes<sup>62,95,96,97</sup>, the culture and identification of bacterial species from a paper point sample is still a monumental task. Furthermore, the results obtained in terms of cultivable microorganisms may bear little relationship to the content of the original sample because of distortion introduced by the sampling technique<sup>95</sup>, the dispersion of the sample<sup>98</sup>, and the ability of bacteria to grow on available media.<sup>91</sup> These variations are due to the fact that different microorganisms are affected to varying degrees by the successive steps involved in their cultivation. The cumulative effect of these events will thus result, not only in a markedly distorted picture of the actual microbial composition of a sample, but also in a decreased likelihood of obtaining meaningful results.

Listgarten and Lewis emphasized the need to remove the bulk of the overlying flora which could otherwise distort the true composition of the bacterial population in the immediate vicinity of the affected tissues. For these reasons, the sampling technique employed in this study was confined to the subgingival area after obvious supragingival bacterial deposits were removed. The data, therefore reflect proportions of bacterial types as they exist primarily in a subgingival location.

The approach to studying bacterial specificity in periodontal disease by eliminating the pathogenic flora with antimicrobial agents and monitoring disease activity has been proposed by Socransky (1977).<sup>1</sup>

In the four juvenile periodontitis patients observed in this study, removal of a predominantly anaerobic subgingival microflora by the local administration of tetracycline or by mechanical debridement was correlated with improved clinical status as measured by decreased pocket depth as well as decreased gingival inflammation and plaque accumulations.

The finding in this study that a large percentage (75%) of the subgingival microflora of juvenile periodontitis is anaerobic is supported by two recent studies. In 1979, Slots found that in nine subjects with juvenile periodontitis, the subgingival microflora consisted of predominantly anaerobic microorganisms (86%) as compared to his control values (41%).<sup>4</sup> Newman and Socransky (1977) studied 14 subjects with juvenile periodontitis and found the subgingival microflora to consist of 77% anaerobic microorganisms<sup>67</sup> (See Tables 1 and 2). They concluded that a difference existed in the microbiota found in the advancing front

of juvenile periodontitis lesions when compared to healthy controls in the same individual.

The data presented in this study indicated that deep pockets of juvenile periodontitis may have a relatively characteristic microflora. Slots (1979) has indicated that the dominating organism in these deep pockets are Gram-negative, anaerobic rods comprising approximately 60% of the total subgingival microflora.<sup>4</sup>

Obviously, another control situation to be considered is the microflora of deep pockets associated with the "common" type of chronic destructive periodontitis. From such pockets, the facultative Gram-positive cocci and rods were the most common isolates, according to Gibbons, et al. (1963)<sup>100</sup> Dwyer and Socransky (1968)<sup>101</sup> Salkind, et al. (1971)<sup>102</sup> and Sabiston and Grigsby (1972).<sup>103</sup> Later, findings obtained by the use of the roll tube technique indicated a predominance of Gram-negative rods.<sup>2</sup> It is unknown, however, if differences between the findings of the authors mentioned, and between the present data and those of other authors, reflect real differences in the microbiology of the lesions investigated, or if they are due to the use of different media and methods of anaerobic incubation. More information on the microflora of deep periodontal pockets of the "common" type and of juvenile periodontitis as well as on the various growth media and techniques is needed in order to establish comparisons between the two types of periodontal disease.

From the results presented in this study, it is apparent that at treated sites, the Gingival Index scores, Plaque Index scores and probing

measurements were reduced from baseline values at the 2-, 4-, and 12- week examinations as a result of the two treatment modalities. In general, the reduction of the clinical symptoms of periodontal pathology occurred within the first two weeks after treatment. After this period, a gradual return to baseline values occurred with the greatest shift occurring between the 4th and 12th week.

The two experimental groups exhibited a downward trend in plaque scores, principally due to improved oral hygiene. It should be noted, however, that the Plaque Index system scores only supragingival plaque and that microbial deposits in a subgingival location are not generally recorded. Therefore, it is conceivable that significant changes may have taken place subgingivally both in the bacterial mass and in composition that were not detected by the Plaque Index system.

The change in the relative proportions of the subgingival microflora were particularly noteworthy. The results indicated that the percentage of anaerobic and facultative microorganisms changed dramatically during the course of this experiment following the two treatment modalities. Associated with this bacteriological shift, a concomitant shift in the clinical parameter occurred. This suggests that the improvement in the clinical parameters of all the subjects two weeks following the treatments could be associated with the concomitant decrease of anaerobic microorganisms or increase of facultative microorganisms. As the subgingival microflora returned to baseline value in the course of the experiment, a similar trend was also noted in the clinical parameter scores.



The results suggest that the microflora typical of that observed at a periodontically-diseased site in a patient with juvenile periodontitis can be shifted through treatment to one more typical of the flora observed at a healthy site. While an effect on the flora is not unexpected by a broad spectrum antibiotic, it is noteworthy that this effect occurred by a single application of the antibiotic via hollow fibers at a very low dosage and that a similar effect could be produced through mechanical debridement. Furthermore, this effect is noticeable for at least two weeks following a single course of scaling and root planing or local tetracycline therapy. After this period, the pockets began to repopulate with the more anaerobic type of microflora.

The fact that such a small amount of tetracycline within the hollow fiber could produce the striking results of this study corroborates well with the study of Lindhe, et al.<sup>13</sup> in which 5 patients with severe periodontitis were treated with localized tetracycline therapy via hollow fibers. In an earlier study by Goodson, et al.<sup>12</sup> the kinetics of this slow-release device was discussed.

In their study the theoretical reservoir capacity of the hollow fiber delivery system was computed.<sup>12</sup> Their experiments indicated that as much as 340  $\mu\text{g}/\text{cm}$  could be loaded. Since antibacterial concentrations of tetracycline are between 1 and 10  $\mu\text{g}/\text{ml}$ , 340  $\mu\text{g}$  of drug would be capable of raising 34-340 ml of gingival fluid to therapeutic levels.<sup>12</sup> Since the flow of gingival sulcus fluid from an individual pocket is seldom greater than 10  $\mu\text{l}/\text{h}$ , the amount of drug in 1 cm of fiber delivered

at a constant rate of 0.1  $\mu\text{g}/\text{h}$  could maintain a level of 10  $\mu\text{g}/\text{ml}$  for 4.7 month when placed in the periodontal pocket.<sup>12</sup> This example indicates that a reservoir of these dimensions is sufficient to contain adequate drug loads of therapeutic value when applied to the microregion of the periodontal pocket.

The significance of such a delivery system is obvious since very small dosages of the antitiotic is used compared to systemic therapy virtually eliminating the side effects of tetracycline shown in Table 3.

The results indicating the percentage of tetracycline-resistant microorganisms following the two treatment modalities show high variance between the subjects in each group. This variability could be attributed to faulty sampling or to the incorporation of inactivated or partially inactivated tetracycline hydrochloride into the culture media on the day the culture plates were prepared. It would seem unlikely that such high percentage of resistant microorganisms seen in both groups could exist. However, a study by Williams, et al.<sup>9</sup> has shown that the fluid crevicular concentration of tetracycline of 2-4  $\mu\text{g}/\text{ml}$  was far below the minimum inhibitory concentration for the facultative streptococci isolated from 13 patients. In this study, the culture media contained only 1.0  $\mu\text{g}/\text{ml}$  of tetracycline allowing the facultative streptococci to survive. Interestingly, this could also explain why the percentage of resistant microorganism increased two weeks following treatment in all the patients since a concomitant increase of the percentage of facultative microorganism had also occurred. Furthermore, as the percentage of facultative

microorganism decrease during the 20-week period, a simultaneous decrease in the percentage of resistant microorganisms occurred. In future studies, a larger dosage of tetracycline in the culture media must be used or minimum inhibitory concentrations determined in order to obtain more significant results.

At the present time, it seems premature to attempt to predict the significance of the present investigation to the prevention or treatment of periodontal disease. It is felt that more patients with juvenile periodontitis should be studied in a variety of treatment modalities. The methods employed in this study do not lend themselves to epidemiological investigations. Nonetheless, this study, if somewhat expanded, could provide a basis for the rational choice of treatment of juvenile periodontitis.

## SUMMARY AND CONCLUSION

The present investigation demonstrated that it is possible, by use of tetracycline-filled hollow fibers to (1) markedly change the composition of the subgingival flora of initially diseased sites of patients with juvenile periodontitis, and (2) to reduce clinical symptoms of periodontal pathology.

Subgingival scaling and root planing produced similar conspicuous changes in the subgingival microflora and clinical parameters. Furthermore, a comparison between the effects obtained by mechanical and chemical treatment regarding alterations of the subgingival microflora, gingival inflammation and probing depth reveals a close association between the degree of change of the microflora and the degree of improvement of the clinical parameters of juvenile periodontitis.

Studies can be keyed from these results in order to determine if the effectiveness of this form of therapy can be improved by alteration of the schedule for local delivery of antibiotics in the treatment of juvenile periodontitis.

## REFERENCES

1. Socransky, S.S.: Microbiology of periodontal disease - Present status and future considerations. *J. Periodontol.* 48:497, 1977.
2. Crawford, A., Socransky, S.S. and Bratthall, G.: Predominant cultivable microbiota of advanced periodontitis. *Journal of Dent. Research (Special Issue A)* 54:97, Abst. No. 209, 1972.
3. Van Palenstein Helderma, W.H.: Total viable count and differential count of vibrio sputorum, fusobacterium nucleatum, selenomonas sputigena, bacteroides ochraceus, and veillonella in the inflamed and non-inflamed human gingival crevice. *J. Periodontol. Res.* 10:294, 1975.
4. Slots, J.: The predominant cultivable organisms in juvenile periodontitis. *Scand. J. Dental Res.* 84:1, 1976.
5. Newman, H. and Socransky, S.S., and Listgarten, N.A.: Relationship of microorganism to the etiology of periodontosis. *J. Dental Res.* 53:135, 1974.
6. Listgarten, N.A., Lindhe, J., and Hellden, L.B.: The effect of tetracycline and/or scaling on human periodontal disease, Clinical, microbiological, and histological observations. *J. Clin. Periodontol.* 5:246, 1978.
7. Genco, R., Singh, S., Krygier, G. and Levine, M.: Use of tetracycline in the treatment of adult periodontitis. I: Clinical studies. *J. Dent. Res.* 57:266, Abst. No. 768., 1973.
8. William, B.L., Osterberg, A., and Jorgensen, J.: Subgingival microflora of periodontal patients on tetracycline therapy. *J. Clin. Periodontol.* 6:210, 1979.
9. William, B.L., Osterberg, A., and Jorgensen, J.: Subgingival microflora of periodontal patients on tetracycline therapy. *J. Clin. Periodontol.* 6:210, 1979.
10. Listgarten, M.A., Lindhe, J. and Paroli, R.: The effect of systemic antimicrobial therapy on plaque and gingivitis in dogs. *J. Periodontol Res.* In press.

11. Williams, R.C., Sandler, M.B., Aschaffenburg, P.H., and Goldhaber, P.: Preliminary observations on the inhibitory effect of tetracycline on alveolar bone loss in beagle dogs. *J. Periodontal Res.* 14:341, 1979.
12. Goodson, J.M., Haffajee, A., and Socransky, S.S.: Periodontal therapy by local delivery of tetracycline. *J. Clinical Periodontol.* 6:141, 1979.
13. Lindhe, J., Heijl, L., Goodson, J.M. and Socransky, S.S.: Local tetracycline delivery using hollow fiber devices in periodontal therapy. *J. Clinical Periodontol.* 6:141, 1979.
14. Russell, A.L.: Epidemiology of periodontal disease. *Int. Dent. J.*, 17:1, 1967.
15. Gottlieb, B.: Die diffuse Atrophic des Alveolar-knochens. *Zeitschrift fur Stomatologie.* 21:195, 1923.
16. Gottlieb, B.: The formation of the pocket: diffuse atrophy of alveolar bone. *J. Amer. Dent. Assoc.* 15:462, 1928.
17. Wannemacher, E.: Umachau auf dem Gebiet der Passdentose. *Keiferheilkunde* 3:81, 1938.
18. Miller, S.C., Wolf, W. and Seidler, B.B.: Systemic aspects of precocious advanced alveolar bone destruction, *J. Dent. Res.* 20:386, 1941.
19. Thoma, K.H. and Goldman, H.M.: Wandering and elongation of the teeth and pocket formation in periodontosis. *J. Amer. Dent. Assoc.* 27:335, 1940.
20. Orban, B. and Weinmann, J.P.: Diffuse atrophy of the alveolar bone (periodontosis). *J. Periodontol.* 13:31, 1942.
21. American Academy of Periodontology: Report of the 1949 Nomenclature Committee. *J. of Periodontol.* 21:40, 1950.
22. Tenenbaum, B., Karahan, M., Qiskin, D. and Nahoum, H.I.: Clinical and microscopic study of the gingivae in periodontosis. *J. Amer. Dent. Assoc.* 40:302, 1950.
23. McCall, J.D.: Advanced alveolar bone destruction. *J. Amer. Dent. Assoc.* 42:355, 1951.
24. Wasserman, B.H., Thompson, R.H., Geiger, A.M., Goodman, S.F., Buebe, F.E.: Relationship of occlusion and periodontal disease, Part II. *J. of Periodontol.* 42:371, 1971.

25. Glickman, I.: Periodontosis: a critical evaluation. *J. of Amer. Dent. Assoc.* 44:706, 1952.
26. Yount, J.G. and Belting, C.M.: Periodontosis: a review of the literature. *J. Periodontol.* 27:149, 1956.
27. Lyons, H., Bernier, J. and Goldman, H.M.: Nomenclature and classification committee. *J. of Periodontol.* 30:74, 1959.
28. Ramfjord, S.P.: The periodontal status of boys 11 to 17 years old in Bombay, India. *J. of Periodontol.* 32:237, 1961.
29. Baer, P.N., Stanley, H.R., Brown, K., Smith, Gamble, J. and Siverdlow, H.: Advanced periodontal disease in an adolescent (periodontosis). *J. Periodontol.* 34:533, 1963.
30. Baer, P.N. and Kaslick, R.S.: Periodontosis: A confusion of terminology. *J. Periodontol.* 49:153, 1978.
31. Seidler, B., Miller, S. and Wolf, W.: Systemic aspects of precocious advanced alveolar bone destruction: preliminary report. *J. Amer. Dental Assoc.* 40:49, 1950.
32. Hormand, J. and Frandsen, A.: Localization of bone loss in juvenile periodontitis. N.O.F. Scandinavian Division. of IADR. Abst. No. 1, 1976.
33. Pritchard, J.F.: Advanced Periodontal Disease: Surgical and Prosthetic Management. pp. 40-50. Philadelphia: Saunders, 1965.
34. Workshop in Periodontics, Ann Harbor, Mich.: Editorial Committee: Sigmund Ramfjord. p. 123, 1966.
35. Kaslick, R.S. and Chasens, A.I.: Periodontosis with periodontitis: a study involving young males. 1. Review of the literature and incidence in a military population. 2. Clinical, medical, and histopathologic studies. *Oral Surgery, Oral Medicine and Oral Pathology* 25:305, 1968.
36. Kaslick, R.S., Chasens, A.I., Bressman, E., Lazzara, R., and Egitto, A.: Investigation of periodontosis with periodontitis: ultramicroanalysis of gingival fluid, gross examination of the periodontal ligament and approach to treatment. *J. Periodontol.* 42:428, 1971a.
37. Stein, G.M.: A clinical evaluation of patients with periodontitis. *Penn. Dental Journal* 36:301, 1969.

38. Baer, P.N.: The case for periodontosis as a clinical entity. *J. Periodontol.* 42:516, 1971.
39. Benjamin, S.D. and Baer, P.N.: Familial patterns of advanced alveolar bone loss in adolescence (periodontosis). *Periodontics* 5:82, 1967.
40. Baer, P.N. and Gamble, J.W.: Autogenous dental transplant as a method of treating the osseous defect in periodontosis. *Oral Surgery, Oral Medicine, and Oral Pathology* 22:405, 1966.
41. Borring-Moller, G. and Frandsen, A.: Autologous tooth transplantation to replace molars in patients with juvenile periodontitis. *J. Clin. Periodontol.* 5:152, 1978.
42. Butler, J.H.: A familial pattern of juvenile periodontitis (periodontosis). *J. Periodontol.* 40:115, 1969.
43. Chaput, A.: *Stomatologic.* Paris. Flammarion. 1967.
44. Bouyssow, M. and Fourel, J.: La parodontite argue juvenile. *Acta Stomatologica Belgica* 70:71, 1973.
45. Fourel, J.: Periodontosis, juvenile periodontitis, or Gottlieb syndrome? Report of 4 cases. *J. Periodontol.* 45:234, 1974.
46. Manson, J.D. and Lehner, T.: Clinical features of juvenile periodontitis (periodontosis). *J. Periodontol.* 45:636, 1974.
47. Lehner, T., Wilton, J.M.A., Ivanyi, L. and Manson, J.O.: Immunological aspects of juvenile periodontitis (periodontosis). *J. of Periodontol. Res.* 9:261, 1974.
48. Sugarman, M.M. and Sugarman, E.F.: Precocious periodontitis: a clinical entity and a treatment responsibility. *J. Periodontol.* 48:397, 1971.
49. Waerhaug, J.: Subgingival plaque and loss of attachment in periodontosis as observed in autopsy material. *J. Periodontol.* 47:636, 1976.
50. Waerhaug, J.: Subgingival plaque and loss of attachment in periodontosis as evaluated on extracted teeth. *J. Periodontol.* 48:125, 1977.
51. Waerhaug, J.: Plaque control in the treatment of juvenile periodontitis. *J. Clinical Periodontol.* 4:29, 1977a.



52. Genco, R.J., Evans, R.T., and Ellison, S.A.: Dental research in microbiology with emphasis on periodontal disease. *J. Amer. Dent. Assoc.* 78:1016, 1969.
53. Ellison, S.A.: Oral bacteria and periodontal disease. *J. Dent. Res.* 49:198, 1970.
54. Keyes, P.H.: Are periodontal pathoses caused by bacterial infections or cervicoradicular surfaces of teeth? *J. of Dent. Res.* 49:223, 1970.
55. Socransky, S.S.: Relationship of bacteria to the etiology of periodontal disease. *J. Dent. Res.* 49:223, 1970.
56. Loe, H., Theilade, E. and Borghlum-Jensen, S.: Experimental gingivitis in man. *J. Periodontol.* 36:177, 1965.
57. Theilade, E., Wright, W.H., Borghlum-Jensen, S. and Loe, H.: Experimental gingivitis in man. III A longitudinal clinical and bacteriological investigation. *J. Periodontal Res.* 1:1, 1966.
58. Loe, H. and Holm-Pedersen, P.: Absence and presence of fluid from normal and inflamed gingivae. *Periodontics* 3:171, 1965.
59. Listgarten, M.A., Mayo, H.E. and Tremblay, R.: Development of dental plaque on epoxy resin crowns in man. *J. Periodontol.* 46:10, 1975.
60. Listgarten, M.A.: Structure of the microbial flora associated with periodontal health and disease in man. A light and electron microscopic study. *J. Periodontol.* 47:1, 1976.
61. Socransky, S.S., Manganiello, A.D., Oram, V., Propas, D., Dogan, I.L. and van Houte, J.: Microbial composition of developing supra-gingival plaque. *J. Periodontol. Res.* 12:90, 1977.
62. Slots, J.: Microflora in the healthy gingival sulcus in man. *Scand. J. Dental Res.* 85:247, 1977b.
63. Loesche, W.J., and Slyed, S.A.: Bacteriology of human experimental gingivitis: Effect of plaque and gingivitis score. *Infect. Immunol.* 21:830, 1973.
64. Slots, S.: The predominant cultivable microflora of advanced periodontitis. *Scand. J. Dent. Res.* 85:115, 1977.
65. Newman, M., Williams, R., Crawford, A., Manganiello, A.D. and Socransky, S.S.: Predominant cultivable microbiota of periodontitis and periodontosis, III. Periodontosis. *J. of Dental Research* 52:131, 1973.

66. Savitt, E.D., Socransky, S.S., Hammond, B.F., and Newman, M.G.: Characterization of fusiform organisms isolated from periodontosis. *J. Dent. Res.* 54:A96, 1975.
67. Newman, M.G. and Socransky, S.S.: Predominant cultivable microbiota in periodontosis. *J. Periodontol. Res.* 13:120, 1977.
68. Krekelei, G. and Fuch, K.: Keimzahlbestimmung der Sulcusflüssigkeit gesunder und entzündeter. *Deutsche Zeitschrift* 32:232, 1977.
69. Irving J.T., Socransky, S.S., Newman, M.G. and Savitt, E.: Periodontal destruction induced by capnocytophaga in gnotobiotic rats. *J. of Dent. Res.* 55:257, 1976.
70. Irving, J.T., Socransky, S.S., and Tanner, A.C.: Histological changes in experimental disease in rats monoinfected with Gram-negative organisms. *J. Periodontal Res.* 13:326, 1978.
71. Tanner, A., Haffer, C., Bratthall, G., Visconti, R., and Socransky, S.S.: A study of the bacteria associated with advancing periodontitis in man. *J. Clin. Periodontol.* 6:278, 1979.
72. Listgarten, M.A. and Hellden, L.: Relative distribution of bacteria at clinically healthy and periodontically diseased sites in humans. *J. Clin. Periodontol.* 5:115, 1978.
73. Lindhe, J.: Prevention of major dental disorders. *J. Clinical Periodontol.* 6:68, 1979.
74. Ponity, D.P., Gershboff, A., and Wells, H.: Passage of orally administered tetracycline into the gingival crevice around natural teeth and around protruding subperiosteal implant abutments in man. *Dent. Clin. North Amer.* 14:125, 1970.
75. Bader, H.I., and Goldhaber, C.: The passage of intravenously administered tetracycline into the gingival sulcus of dogs. *J. Oral. Theo.* 2:180, 1965.
76. Ciancio, S., Singh, S., Genco, R., Krygier, G., and Mather, M.L.: Analysis of tetracycline in human gingival fluid: Methodology and results. *J. Dent. Res.* 55:411, 1976.
77. Hoepflich, P.D., and Warshauer, D.M.: Entry of four tetracyclines into saliva and tears. *Antimicrob. Agents Chemotherap.* 5:330, 1974.
78. Ciancio, S.: Tetracyclines and Periodontal Therapy. *J. Periodontol.* 47:155, 1976.

79. Stahl, S.S.: Influence of antibiotics on the healing of gingival wounds in rats. II. Alveolar bone and soft tissue. *J. Periodontol.* 33:261, 1962.
80. Stahl, S.S.: The influence of antibiotics on the healing of gingival wounds in rats. III Reattachment potential of soft and calcified tissues. *J. Periodontol.* 34:166, 1963.
81. Shaw, J.H., Griffiths, D. and Auskaps, D.M.: The influence of antibiotics on the periodontal syndrome in rice rats. *J. Dent. Res.* 40:511, 1961.
82. Hellden, L.B., Listgarten, M.A., and Lindhe, J.: The effect of tetracycline and/or scaling on human periodontal disease. *J. Clin. Periodont.* 6:222, 1979.
83. Slots, J., Mashimo, P., Levine, M.J., and Genco, R.J.: Periodontal Therapy in Humans: I. Microbiological and Clinical Effects of a single course of periodontal scaling and root planing, and of adjunctive tetracycline therapy. *J. Periodontol.* 50:246, 1979.
84. Waerhaug, J. and Steen, E.: The presence or absence of bacteria in gingival pockets and the reactions in healthy pockets to certain pure cultures. *Odont. Tidskr.* 60:1, 1952.
85. Boyd, W.S., and Rosenthal, S.L.: The presence of bacteria in healthy gingival sulcus. *J. Dent. Res.* 37:288, 1958.
86. Gavin, J.B., and Collins, A.A.: The occurrence of bacteria within the clinically healthy gingival crevice. *J. Periodontol.* 32:198, 1967.
87. Castio, A. de., and Going, D.H.: A bacteriologic and histologic investigation of the healthy gingival sulcus in young dogs and children. *J. Periodontol.* 35:216, 1964.
88. Wilkinson, E.G.: A technique for sampling deep periodontal pockets for bacteriological studies. *J. Periodontol.* 33:115, 1962.
89. Bervell, S.P.A.: The bacteriology of physiological gingival pockets. *Arch. Odont. Scand.* 22:167, 1968.
90. Kelstrup, J.: Improved bacterial sampling from healthy and inflamed gingival sulci. *Periodont.* 4:11, 1971.
91. Slots, J.: Comparison of five growth media and two anaerobic technique for isolating bacteria from dental plaque. *Scand. J. Dent. Res.* 83:274, 1975.

92. Løe, H. and Silness, J.: Periodontal disease in pregnancy. I Prevalence and severity. *Acta Odontologica Scand.* 21:533, 1963.
93. Silness, J. and Loe, H.: Periodontal disease in pregnancy. II. Correlation between oral hygiene and periodontal condition. *Acta Odontol. Scand.* 22:121, 1964.
94. Loesche, W.J.: Chemotherapy of dental plaque infections in preventive dentistry: Nature, pathogenicity and clinical control of plaque. *Oral Sciences Reviews* 9:65, 1976.
95. Aranki, A., Lyed, S.A., Kenney, E.B. and Freter, R.: Isolation of anaerobic bacteria from human gingiva and mouse cecum by means of a simplified glove box procedure. *Applied Microbiology* 17:568, 1969.
96. Gordon, D.F., Stutman, M. and Loesche, W.J.: Improved isolation of anaerobic bacteria from the gingival crevice area of man. *Applied Microbiol.* 21:1046, 1971.
97. Manganiello, A.D., Socransky, S.S., Smith, C., Propas, D., Dram, V. and Dogon, I.L.: Attempts to increase viable count recovery of human supragingival dental plaque. *J. Periodontol. Res.* 12:107, 1977.
98. Robish, S.A., Grove, S.B., Bernstein, R.S., Maruche, P.T., Socransky, S.S. and Amden, B.: Effect of some treatment on pure cultures and aggregates of bacteria. *J. Clin. Microbiol.* 3:474, 1976.
99. Listgarten, M.A. and Lewis, D.W.: The distribution of spirochetes in the lesion of acute necrotizing ulcerative gingivitis. An electron microscopic and statistical surgery. *J. Periodontol.* 38:379, 1967.
100. Gibbons, R.J., Socransky, S.S., Sawyer, S., Kapsimalis, B. and McDonald, J.B.: The microbiota of the gingival crevice area of man. II. The predominant cultivable organisms. *Arch. Oral Biol.* 8:281, 1963.
101. Dwyer, D. and Socransky, S.S.: Predominant cultivable microorganisms inhabiting periodontal pockets. *British Dent. J.* 129:560, 1968.
102. Salkind, A., Oshrain, H.I. and Mandel, I.D.: Bacterial aspects of developing supragingival and subgingival plaque. *J. Periodontol.* 42:706, 1971.
103. Sabiston, C.B., Jr. and Grigsby, W.R.: Anaerobic bacteria from the advanced periodontal lesion. *J. Periodontol.* 43:199, 1972.

APPROVAL SHEET

The thesis submitted by Frank Anthony Riccoboni, D.D.S. has been read and approved by the following committee:

Dr. Kirk Hoerman, Director  
Associate Professor, Preventive Dentistry  
and Community Health, Loyola

Dr. Anthony Gargiulo  
Chairman and Clinical Professor,  
Department of Periodontics, Loyola

Dr. James Hagen  
Assistant Professor,  
Microbiology, Loyola

Dr. Patrick Toto  
Professor and Chairman,  
Oral Pathology, Loyola

The final copies have been examined by the director of the thesis and the signature which appears below verifies the fact that any necessary changes have been incorporated and that the thesis is now given final approval by the Committee with reference to content and form.

The thesis is therefore accepted in partial fulfillment of the requirements for the degree of Master of Science in Oral Biology.

4/26/81  
Date

Kirk C. Hoerman  
Director's Signature