



1983

Some Effects of Naturally Occurring Amygdalin on Female C3H/ HeJ Mice

Gareth Eli Shemesh
Loyola University Chicago

Follow this and additional works at: https://ecommons.luc.edu/luc_theses



Part of the [Biology Commons](#)

Recommended Citation

Shemesh, Gareth Eli, "Some Effects of Naturally Occurring Amygdalin on Female C3H/HeJ Mice" (1983).
Master's Theses. 3302.

https://ecommons.luc.edu/luc_theses/3302

This Thesis is brought to you for free and open access by the Theses and Dissertations at Loyola eCommons. It has been accepted for inclusion in Master's Theses by an authorized administrator of Loyola eCommons. For more information, please contact ecommons@luc.edu.



This work is licensed under a [Creative Commons Attribution-Noncommercial-No Derivative Works 3.0 License](#).
Copyright © 1983 Gareth Eli Shemesh

SOME EFFECTS OF NATURALLY OCCURRING AMYGDALIN
ON FEMALE C3H/HeJ MICE

by

Gareth Eli Shemesh

A Thesis Submitted to the Faculty of the Graduate School
of Loyola University of Chicago in Partial Fulfillment
of the Requirements for the Degree of
Master of Science

May

1983

ACKNOWLEDGMENTS

I wish to express my sincere appreciation to Dr. Harold W. Manner for the suggestion of the problem and for his professional and technical guidance, friendship, encouragement, and for the knowledge which he has imparted upon me over the past two years.

Special thanks are due to the other members of my thesis committee, Drs. William Cordes, Amrik Dhaliwal and Anthony Nappi for their willingness to serve on my thesis committee, their encouragement, and for their friendship.

Special thanks are also due to my colleagues William Smyka and Micheal Gruenberg, for their interest, contribution and, above all, for their friendship.

Acknowledgment is also given to the National Health Federation and the Metabolic Research Foundation for their interest and support.

Lastly, I would like to express sincere gratitude to my parents, Rita and Alvin Shemesh, for their continuous love, guidance, support and encouragement provided me in my academic endeavors.

VITA

The author, Gareth Eli Shemesh, is the third of four sons of Dr. Alvin and Rita F. Shemesh. He was born June 4, 1958, in Minneapolis, Minnesota.

His elementary education was obtained at the Cornelia Latin Grammar School, and secondary education at St. John's Preparatory School in Collegeville, Minnesota.

In September, 1975, he entered St. John's University in Collegeville, Minnesota, and in June 1979, received the degree of Bachelor of Arts with a major in German and a major in Natural Science.

In September, 1979, he entered the Master's degree program in Biology at Loyola University of Chicago and was granted a graduate research assistantship.

TABLE OF CONTENTS

Acknowledgments	ii
Vita	iii
List of Tables	v
List of Figures	vi
Chapter	
I. Introduction	1
II. Review of Literature	7
III. Materials and Methods	31
IV. Results	34
V. Discussion	41
Literature Cited	46

LIST OF TABLES

Table	Page
I. Foods Containing Amygdalin	12
II. Important Plants Containing Cyanogenic Glycosides	13
III. Effects of Orally Ingested Amygdalin on Mortality of Female C3H/HeJ Mice	40

LIST OF FIGURES

Figure	Page
1. Chemical Structure of Amygdalin	8
2. Chemical Structure of Laetrile	10
3. Degradation of Amygdalin	15
4. Cyanide Detoxification by Rhodanese	19
5. Percentage of Tumorous Mice in Control and Experimental Groups	35
6. Mean Number of Months Required for Tumor Formation	36
7. Mean Life Span of Female C3H/HeJ Mice	37
8. Comparison Between Tumorous and Non-tumorous Control and Experimental Mice	39

CHAPTER I

INTRODUCTION

Amygdalin has been used as an anticancer agent for many centuries. Dating back to circa 2800 B.C., during the reign of China's Emperor Shen Nung, the apricot kernel and other amygdalin bearing plants were used for cancer treatment (Halstead, 1977). In England, during the seventeenth century, apricot oil was used against tumors or swellings of ulcers (Lewis and Elvin-Lewis, 1977). In a study sponsored by the National Cancer Institute, Wodinsky and Swiniarski (1975) state that "amygdalin found in the kernels of bitter almonds, peaches, and apricots, has been used in cancer chemotherapy since 1845." Currently pure amygdalin, isolated from apricot kernels, is being used, legally in many foreign countries and in many states of the United States.

Amygdalin is one of the most widely distributed cyanogenic glycosides. It is commonly found in members of the Rosaceae (rose family) (Lewis and Elvin-Lewis, 1977). Amygdalin is also known variously as nitrilosides, Laetrile, or Vitamin B₁₇. Upon hydrolysis of amygdalin, a two-step process, two molecules of glucose are released as well as benzaldehyde, and hydrocyanic acid (Montgomery, 1969). In 1950 Ernst T. Krebs, Jr. theorized that it was the hydrogen cyanide released from amygdalin that exerted its antineoplastic effects on cancer cells

(Griffin, 1974).

The exact mechanism of action of amygdalin is not known, but several hypotheses have been presented (Halstead, 1977). The most widespread theory on the action of amygdalin has been forwarded by Ernst T. Krebs, Sr. and Jr.. According to them, amygdalin is broken down in the body by enzymes, and it is due to varying concentrations of those enzymes that it has a specific effect. Cancer cells have high levels of the enzymes B-glucosidase and B-glucuronidase which break down amygdalin and liberate hydrogen cyanide (Fishman and Anlyan, 1947; Haisman and Knight, 1967; Culbert, 1974; Krebs, 1967, 1970). According to the Krebs' theory it is the high concentration of B-glucuronidase found in cancer cells that allows for the selective release of hydrogen cyanide from the amygdalin at the cancer site (Krebs, 1970). Normal cells are protected from the hydrogen cyanide by the presence of the enzyme rhodanese which converts hydrocyanic acid to thiocyanate (Mendel, Rudney and Bowman, 1946; Giordano et al., 1956; Oke, 1969). Hydrolysis of amygdalin is a two-step oxidative process and its occurrence in the body has not been established scientifically.

Much of the Krebs' "cyanide theory" is based upon work done previously by Beard (1902). According to Beard's "Trophoblastic Thesis of Cancer", the cancer cell is the same as the trophoblast cell in pregnancy. In some instances, however, the trophoblast cell, which is normal during pregnancy, becomes misguided and under the influence of the sex hormone estrogen is transformed into a malignant cell. After further investigation of Beard's theory, Krebs et al.

(1950) published a paper indicating that the trophoblast cell in pregnancy was inhibited by pancreatic enzymes and they inferred that the trophoblast cell outside of pregnancy (the malignant cell) should also be inhibited by the pancreatic enzymes. Krebs, Jr. experimented further with the use of pancreatic enzymes against cancer, and he claimed to have had some positive results using chymotrypsin, but he noted that it lacked the force to do the specific job that Beard had attributed to it in his theory (Culbert, 1974). So, Krebs, Jr. continued with his research in this area, which ultimately led him to the formulation of an extract from apricots, which he called "Laetrile".

Currently, amygdalin is being used in the form of Krebs' Laetrile. Krebs, Jr. first reported in 1950 that he had synthesized this compound from the apricot kernel (Griffin, 1974). He came up with the word Laetrile since it was derived from a laevorotary nitrile and subsequently patented the compound. The main difference between amygdalin and Laetrile is that amygdalin contains 2 glucose molecules and Laetrile has only one.

In addition to therapeutic use, it has been proposed by proponents of amygdalin that by maintaining an adequate level of amygdalin in one's diet, it will have a specific cancer preventative and controlling effect (Krebs, 1970; Larson, 1972; Griffin, 1974; Culbert, 1974). The theory that amygdalin actually prevents or retards the growth of cancer cells is based on two lines of reasoning. One is that doctors who have used nitrilosides on thousands of patients are enthusiastic about the results. They do not claim that it cures cancer, only that

in many instances it halts the deadly progress of the disease. The other line of reasoning is that so-called primitive peoples, in whom most forms of cancer are extremely rare, eat a diet containing a large amount of amygdalin. Conversely, in nations where cancer is near the top of the killer list, the diet contains very little or no nitrilosides (Krebs, 1967; Larson, 1972; Griffin, 1974).

Experimental evidence to support the theory that amygdalin is cancer preventive is somewhat limited, however it is still used by many people throughout the world for that purpose. A report by Stock et al. (1978) indicates that in mice injected intraperitoneally with amygdalin at a dosage of 1000 mg/kg/day, 17% developed lung metastases and 72% tumors. In the control group, 81% developed lung metastases and 82% tumors. In France, Metianu (1977) treated mice subcutaneously two to three times per week with 500 mg/kg of amygdalin after inoculating them with 5×10^8 cells of adenocarcinoma. The experimental group lived an average of 58 days past the time of tumor take and the controls survived an average of 21 days. In West Germany it was found that in mice with Ehrlich Ascites Carcinoma, bitter almonds given in addition to standard feed in a free food choice caused a significant prolongation of survival time, which could be associated with inhibition of tumor growth (Reitnauer, 1974). Manner et al. (1978), reports that when amygdalin is used in conjunction with megadoses of Vitamin A and certain enzymes, there is complete regression of primary mammary tumors in C3H/HeJ mice in 89.3% of the cases. No study has been done on the effects of naturally occurring amygdalin (apricot kernels) on

the prevention of spontaneous mammary tumors in female C3H/HeJ mice.

Although many toxicity studies on amygdalin have been carried out, they lack uniformity. Trube-Becker (1965) estimated that 50-70 raw almond kernels would have to be eaten to provide a lethal dose to adults and as few as 7-10 almonds for a child. Burk (1971) found that amygdalin in doses as high as 10 gm/kg were non-toxic to adult animals. Amygdalin administered intramuscularly in doses ranging from 1000-2500 mg/kg for 15 days was found to be non-toxic (Manner, DiSanti and Michalsen, 1977). Hill et al. (1976) reported no toxicity with doses ranging from 50 to 500 mg/kg for 4 days, but when doses reached 2000 mg/kg for 4 days there was a five percent death rate. Amygdalin MF used by Wodinsky and Swiniarski (1975) at 800 mg/kg intraperitoneally, on mice for nine days showed no toxic effects. However, Khandekar and Edelman (1979) indicate that amygdalin given to Fischer 344 rats in doses of 250, 500, and 750 mg/kg intraperitoneally daily for five days caused mortalities of 30.8%, 44.1%, and 56.8% respectively. There are also a number of articles in the literature associating fatal cyanide poisoning with the ingestion of amygdalin (Pijoan, 1942; Sayre and Kaymakcalan, 1964; Townsend and Boni, 1975; Humbert et al., 1977; Sadoff et al., 1978). More recently though, it was reported that six patients receiving Laetrile either intravenously or orally experienced no toxic effects that could be directly ascribed to Laetrile therapy (Henney, 1980). Certainly, it is evident that the question of amygdalin toxicity is unclear.

The purpose of the present study is to evaluate the importance

of naturally occurring amygdalin (apricot kernels) in the prevention of spontaneous mammary tumors in female C3H/HeJ mice and to look at its effects on longevity and the time required for initial tumor appearance. This study will also look for any possible toxic effects when amygdalin is administered by this route.

CHAPTER II

REVIEW OF RELATED LITERATURE

AMYGDALIN

Amygdalin belongs to a family of compounds known as cyanogenic glycosides. A cyanogenic glycoside is a compound containing sugar and having the capacity of producing prussic acid or hydrocyanic acid (Halstead, 1977). Other members of this family include prunasin, linamarin, sambunigrin, lotusin and dhurrin.

Amygdalin is one of the earliest investigated cyanogenic glycosides. It was first isolated from bitter almonds by the French chemists Robiquet and Boutron-Charland in 1830. Its chemical properties were first worked out by Liebig and Wöhler (1837) where they indicated that amygdalin was hydrolyzed with the evolution of benzaldehyde and hydrogen cyanide by an enzyme preparation from bitter almonds, which they called "emulsin". The word "amygdalin" is derived from the Greek word "amygdale", meaning almond. Amygdalin is listed in the Merck Index (1976) and is described as D-mandelonitrile-β-D-glucosido-6-β-D-glucoside. The empirical formula of amygdalin is $C_{20}H_{27}NO_{11}$ and its molecular weight is 457.42. The elemental composition is C 52.51%, H 5.95%, N 3.06%, and O 38.47%. (See Figure 1 for the molecular structure).

FIGURE 1. Amygdalin

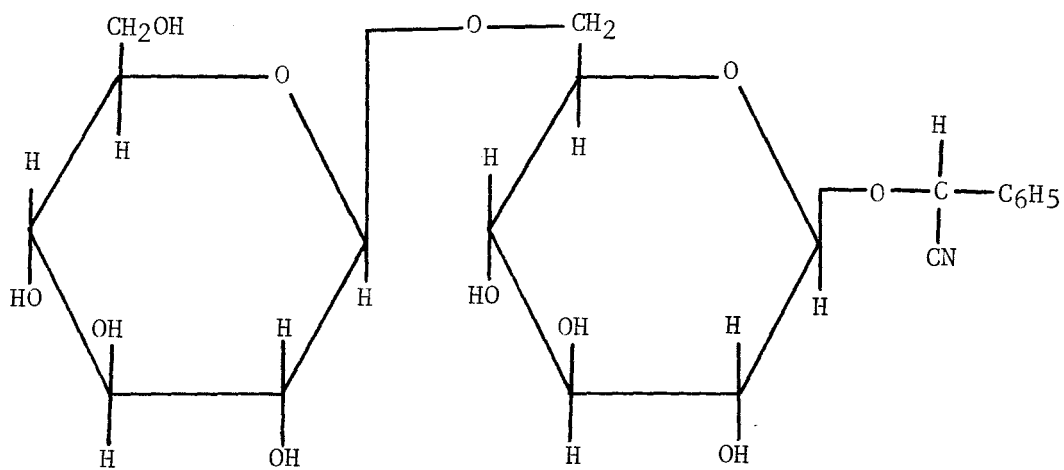

The term amygdalin is often used interchangeably with the word Laetrile. Laetrile is the form of amygdalin which is currently being used by cancer patients seeking therapeutic benefits. However, amygdalin and Laetrile are not chemically synonymous compounds. In 1950, Krebs, Jr. coined the term Laetrile by combining the last five letters of the suffix -nitrile with the first three letters of laevorotary, since the compound was a laevorotary nitrile (Manner *et al.*, 1978). In the Merck Index (1976), Laetrile is defined as l-mandelonitrile-B-glucuronic acid. It has an empirical formula of $C_{14}H_{15}NO_7$ and a molecular weight of 309.27. The elemental composition is C 54.37%, H 4.89%, N 4.53% and O 36.21%. (See Figure 2 for the molecular structure). Laetrile may be synthesized by the hydrolysis of amygdalin and oxidation of the resulting l-mandelonitrile with platinum black; by the condensation of mandelonitrile with glucuronic acid; or by the condensation of mandelonitrile with glucose and subsequent oxidation (Krebs and Krebs, 1958). Although some confusion arises between the use of the two terms amygdalin and Laetrile, Krebs, Jr. designates the term Laetrile to refer to any beta-cyanogenic glucosides which include amygdalin and any of its chemical derivatives (Halstead, 1977).

NATURAL SOURCES OF AMYGDALIN

Amygdalin is most commonly found in members of the Rosaceae (rose) family. It is found in large quantities in the seeds of apples and pears and in the kernels, bark, and leaves of apricots, bitter almonds, wild and domestic cherries, peaches and plus (Lewis and Elvin-

FIGURE 2. Laetrile

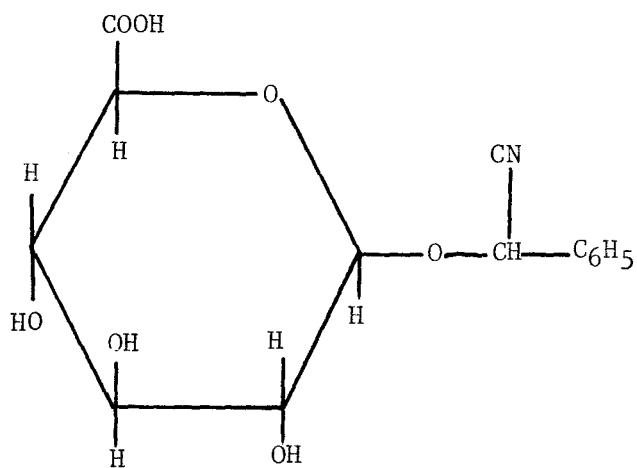

Lewis, 1977). In addition to the seeds and kernels above, cyanogenic glycosides are also present in millet, cassava, maize, sorghum, field bean, lima bean, bamboo, sugar-cane, kidney bean, sweet potato, lettuce and linseed as well as 150 other foods. Table I gives a more complete listing.

Cyanogenic glycosides can be found in a wide range of plants. Table II presents a selected number of these plants. A great number of genera may also be found in the allied Fabaceae (pea family), as well as in the totally unrelated Poaceae (grass family). Thus, in terms of phylogeny, the cyanogenic glucosides exhibit a wide and repeatedly independent origin (Lewis and Elvin-Lewis, 1977).

Extraction of amygdalin is a relatively simple procedure. Apricot kernels are first ground up and then defatted using ether as a solvent. The defatted residue is boiled in alcohol, filtered and cooled. The amygdalin is then separated from this residue and recrystallized. It is estimated that 33 kernels are needed for each 500 mg tablet and 200 kernels for 3 grams of the intravenous formulation (Holden, 1976).

SUGGESTED MECHANISMS OF ACTION OF AMYGDALIN

Krebs, Jr. introduced the compound Laetrile in the early 1950's (Krebs, Jr. *et al.*, 1958). He claimed it to be a beta-glucuronide analog of amygdalin, in which the gentiobiose portion of amygdalin was replaced by a glucuronic acid molecule. He postulated that this molecule could be hydrolyzed by the enzyme beta-glucuronidase thereby,

TABLE I. Foods containing amygdalin (from Timms et al.).BEANS

Broad Bean (*Vicia Faba*)
 Burma Beans
 Chick Peas
 Lentils (sprouted)
 Lima
 Mung Beans (sprouted)
 Rangoon
 Scarlet Runner

BERRIES

Almost all wild berries
 Blackberry
 Chokeberry
 Christmas berry
 Cranberry
 Elderberry
 Raspberry
 Strawberry

GRASSES

Acacia
 Alfalfa (sprouted)
 Aquatic Grass
 Johnson Grass
 Milkweed
 Sudan Grass
 Tunus Grass
 Velvet Grass
 Wheat Grass
 White Clover

GRAINS

Oat Groats
 Barley
 Brown Rice
 Buckwheat Groats
 Chia
 Flax
 Millet
 Rye
 Vetch
 Wheat Berries

KERNELS OR SEEDS OF FRUITS*

Apple
 Apricot
 Cherry
 Nectarine
 Peach
 Pear
 Plum
 Prune

NUTS

Bitter Almonds
 Macadamia Nuts

SEEDS

Chia Seed
 Flax Seed
 Sesame Seed

MISCELLANEOUS

Bamboo Shoots
 Fuschia Plants
 Sorghum Plant
 Wild Hydrangea
 Yew Tree (needles; fresh leaves)

*Contain the highest concentration of amygdalin.

TABLE II. Important plants containing cyanogenic glycosides, arranged phylogenetically (from Pammel).

Angiosperms: Dicotyledons

CHENOPODIACEAE. Suckleya

PASSIFLORACEAE. Adenia, Passiflora

EUPHORBIACEAE. Manihot, Stillingia

ROSACEAE. Cercocarpus, Cotoneaster, Eriobotrya, Malus, Prunus, Pyrus,
Rhodotypos

FABACEAE. Acacia, Cassia, Colichos, Lotus, Phaseolus, Trifolium, Vicia

SAXIFRAGACEAE. Hydrangea

MYRTACEAE. Eucalyptus

LINACEAE. Linum

OLACACEAE. Ximenia

CAPRIFOLIACEAE. Sambucus

BIGNONIACEAE. Crescentia

ASTERACEAE. Ageratum, Bahia, Florestina

Angiosperms: Monocotyledons

JUNCAGINACEAE. Triglochin

POACEAE. Cynodon, Glyceria, Holcus, Panicum, Sorghum, Zea

releasing its constituent parts: hydrocyanic acid and benzaldehyde.

It has been substantiated for some time now that tumor tissue contains a higher concentration of beta-glucuronidase (Fishman and Anlyan, 1947). Krebs therefore proposed that Laetrile was releasing cyanide selectively at the site of the cancer due to hydrolysis by beta-glucuronidase (Krebs, 1967). However, this claim was disproved as it was shown that Krebs' Laetrile was actually the same as amygdalin which is not broken down by beta-glucuronidase. It has been shown that the hydrolysis of amygdalin is accomplished by the enzyme beta-glucosidase (Haisman and Knight, 1967). Using chromatographic analysis, they indicated that the enzymatic hydrolysis of amygdalin by beta-glucosidase occurs in three steps: first the amygdalin is hydrolyzed to prunasin (D-l-mandelonitrile-B-glucoside) and glucose; next, prunasin is hydrolyzed to D-l-mandelonitrile and glucose; finally, the D-l-mandelonitrile is converted to hydrocyanic acid. Refer to Figure 3.

With this in mind, Krebs then made an alteration in his "cyanide theory" (Greenburg, 1975; Halstead, 1977). He proposed that amygdalin was first being converted to a glucuronide derivative in the liver, which is then circulated to the tumor site where it undergoes hydrolysis by the enzyme beta-glucuronidase, thereby releasing its hydrocyanic acid. This process would require two hydrolytic cleavages by liver beta-glucosidase followed by the conjugation of the resulting mandelonitrile with glucuronic acid by UDP glucuronosyl transferase, but this exact process has not been experimentally demonstrated (Halstead, 1977). However, it has been shown that glucuronide formation does occur in the

FIGURE 3. Degradation of amygdalin.

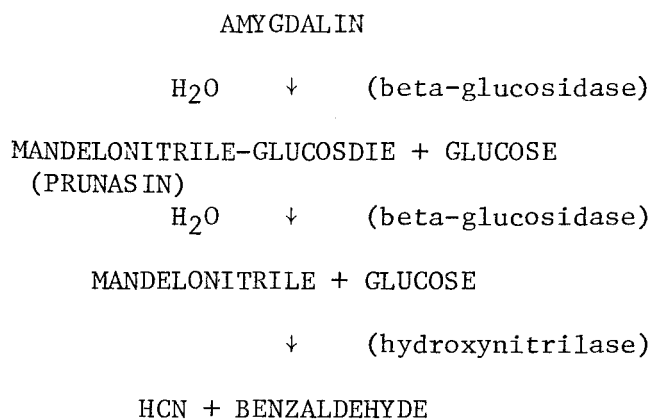

liver and to a lesser extent in the intestines and kidneys (Levy and Conchie, 1966; Miettinen and Leskinen, 1970; White et al., 1973). In addition, research done by Fishman and Anlyan (1947) demonstrates that beta-glucuronidase is present in cancerous tissue of the breast, uterus, stomach, mesentery, abdominal wall and esophagus about 100-3600 times higher than non-cancerous tissue.

Currently, Krebs' version of amygdalin's mechanism of action is as follows: cancer cells have unusually high concentrations of beta-glucosidase, and little or no rhodanese (the enzyme which detoxifies cyanide, producing thiocyanate). The cyanide, being selectively released at the tumor site, then exerts its cytotoxic effects. Research by Manner et al. supports Krebs' claim. They showed that there is a higher concentration of beta-glucosidase in the mammary tumor and the liver of tumor and non-tumor bearing mice in comparison with the brain and muscle tissue of both tumor and non-tumor bearing mice. However, in vitro experiments have repeatedly shown the inability of cancer cells to release cyanide from amygdalin within a reasonable incubation time (Hodges, 1974).

An alternative proposal for amygdalin's action is that it is hydrolyzed to hydrocyanic acid at sites other than the tumor, such as the intestine or possibly the liver. It has been established scientifically that amygdalin is indeed hydrolyzed in the intestinal lumen by bacterial enzymes (Newton et al., 1981; Carter et al., 1980). The high beta-glucosidase content of gut bacteria explains amygdalin's greater oral toxicity. According to this proposal, after amygdalin is hydrolyzed

in the gut it is absorbed into the lymph and portal circulations, creating a low serum cyanide level which is non-toxic to the host, but to which tumor tissue is selectively sensitive.

BETA-GLUCOSIDASE

Beta-glucosidase (EC 3.2.1.21) is known chemically as B-D-glucoside glucohydrolase. It is a hydrolytic enzyme with an optimum pH of 4.4 to 5.0 (Barman, 1969). It is a lysosomal enzyme and may be found in varying amounts in animal tissues (Manner et al., 1978). The term emulsin was originally used to designate this enzyme, but later work showed that emulsin was a mixture of enzymes containing, among others, the specific enzymes beta-glucosidase and beta-oxynitrilase. Beta-glucosidase is specific for the beta-D-glucoside linkage upon which it exerts its hydrolytic action (Greenberg, 1975).

BETA-GLUCURONIDASE

Beta-glucuronidase (EC 3.2.1.31) is known chemically as B-D-glucuronide glucuronohydrolase. It is a hydrolytic enzyme with an optimum pH of 4.3 to 5.0. This enzyme attacks all the natural B-D-glucuronates whether glycoside- or acylal-linked, aliphatic or aromatic, however, it is without activity on A-glucuronides of B-glucosides (Barman, 1969). It is a lysosomal enzyme and is universally distributed in mammalian tissues. It is believed that this enzyme is under endocrine control, but its function in the body remains obscure (Conchie et al., 1961). Levvy and Marsh (1960) indicated that B-glucuronidase plays a role in the catabolism of mucopolysaccharides. It also appears to be associated with an increase in cell proliferation

(Kerr et al., 1949). Fishman and Anlyan (1947) believe that elevated B-glucuronidase is probably a characteristic of malignant cells, but that high B-glucuronidase activity in a tissue does not necessarily imply malignant change.

RHODANESE

Rhodanese (EC 2.8.1.1) is known chemically as thiosulphate sulphurtransferase. It is a mitochondrial enzyme and belongs to a group of enzymes called transferases (Barman, 1969). Dog liver rhodanese is thermolabile, being inactive at 56°, and has optimum activity at about body temperature (38°) and pH 8.3 (Williams, 1959). Rhodanese catalyzes the formation of thiocyanate from thiosulfate and cyanide.

The main pathway for cyanide detoxification is conversion to thiocyanate. Rhodanese is specific for hydrogen cyanide and converts it very rapidly in the presence of sodium thiosulphate or colloidal sulphur into thiocyanic acid. As can be seen in Figure 4 when rhodanese is activated with sodium thiosulphate, it binds a sulphur atom in a charge-transfer complex to the indole nucleus of tryptophan. Thiocyanate is then formed by a nucleophilic attack of cyanide on the sulphur-rhodanese complex (Ferris, 1970). Thus, rhodanese has the ability to neutralize hydrogen cyanide (Osuntokun, 1970; Montgomery, 1969; Oke, 1969).

Cyanide detoxification in the animal body was first shown by Lang (1933) who demonstrated that after the injection of cyanide or of aliphatic nitriles in the rabbit, an increased amount of thiocyanate

FIGURE 4. Cyanide detoxification by rhodanese.

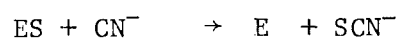
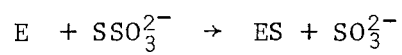

(E = rhodanese)

was excreted in the urine. Rhodanese is present in nearly all animal tissue except in the blood. Rosenthal (1948) and Westley (1973) found spleen and kidney cancer cells to have a lower concentration of rhodanese in comparison to the liver. In the dog, the liver being a major detoxification organ, contains the major part of the body's supply of rhodanese. Lang (1933) found that the amount of liver rhodanese varies from one species of animal to another. According to Lang the rabbit has twenty times as much of the enzyme per 100 grams as does dog liver, and the cow ten times as much. This could be attributed to the fact that the rabbit and the cow are herbivorous. The human has three times as much of the enzyme as the dog. Data from Himwich and Saunders (1948) suggest that even though the liver undoubtedly plays a major role in removing cyanide, detoxification probably occurs in all parts of the body. They also calculated that the whole liver of a dog can theoretically detoxify about 4015 grams of cyanide and the total skeletal muscles 1763 grams to thiocyanate within 15 minutes. However, because the fatal dose of cyanide is so relatively small, they suggest that availability of sulphur, not quantity of enzyme present, is the limiting factor in the in vivo detoxification.

THE USE OF CYANIDE AGAINST CANCER

Since the late 1920's cyanide has been tested as an anti-neoplastic agent. Cyanide combines and forms a complex with iron (III) and other metals present in the respiratory enzyme systems of the cell. Very low concentrations of cyanide can inactivate the cytochrome oxidase enzymes which catalyze oxidative phosphorylation, and the main

supply of energy to the cell ceases. Hydroxycobalamin (Vitamin B₁₂) and methemoglobin (iron (III) haemoglobin) also form complexes with cyanide. These two substances bind cyanide as strongly as the cytochromes and have been used in the treatment of cyanide poisoning (Ferris, 1970).

Karczag (1928) found that with increasing doses of cyanide he could desensitize mice to the muscle cramping effects of KCN. Dosages of KCN administered to mice over periods of weeks and months influenced neither the longevity, the growth, the weight gain, lactation or any other biological process of normal animals. Karczag then inoculated these animals with Ehrlich Ascites Mouse Carcinoma and continued the administration of KCN. He found that the average life span of the treated animals was significantly prolonged over the controls, that tumor growth was slowed, and that 18% of the treated animals had a complete remission. He also noted no evidence of cyanide toxicity.

Other studies using cyanide against cancer have been carried out. Maxwell and Bischoff (1933) exposed animals bearing transplantable tumors (Sarcoma 180, Walker 256 and R-10 sarcoma) to an atmosphere containing HCN (4%) for 5-6 hours daily during the life of the tumor. Although some animals sometimes showed anoxia and prostration there is no mention of chronic toxicity or mortality in treated animals. They conclude that exposure to hydrogen cyanide resulted in a decrease in the rate of tumor growth. A study carried out by Perry (1935), using the Jensen Sarcoma system of rats, also tested CN administered by inhalation. However, a large number of the treated animals died as a

result of toxic effects, although all treated animals, alive and dead, showed marked tumor retardation. She concluded that the range of the effective dose was limited and too close to the lethal dose to be practical. More recently, a study was performed by Brown et al. (1960) who used anesthesia to counter CN toxicity. Their results showed that NaCN administered via IV perfusions in several doses between 0.75 and 1.5 mg/kg could produce life prolongations of 15-85% in Ehrlich Ascites Mouse Carcinoma, of 70% in Sarcoma 180 of rats, and in trials on 18 dogs with spontaneous tumors, produced several apparent cures and a number of significant life prolongations, all without apparent acute or chronic toxicity. They obtained better results with those animals treated most frequently. They also gave results on limited clinical trials on seven terminal patients with gynecological cancer. They detected no observable delayed clinical toxicity. But they did not find any clinical changes in these patients. However, the patients that were selected for the study were those in whom the disease was considered too far advanced to be amenable to the usual form of therapy and they were given only one 5-15 minute IV perfusion of .75-1.0 mg/kg.

TOXICITY STUDIES ON AMYGDALIN

As with any drug the toxic effects of amygdalin are governed by the size of the dose and the method or route of administration. A large number of toxicity studies has been carried out with amygdalin, however there is a great deal of inconsistency in the results obtained from them. Some of this discrepancy can be attributed to the mode of administration. It is well known that high doses given orally have not

proven to be as safe as intramuscular or intravenous injections of equally high doses (Manner et al., 1978). According to Krebs (1970) amygdalin given orally could be 40 times more toxic than parenterally administered doses. Trube-Becker (1965) estimated that 50-70 raw almond kernels would have to be eaten to provide a lethal dose to adults and as few as 7-10 almonds for a child. However, it has been shown that adult mice could live in perfect health to extreme old age when their diet consisted of fifty percent defatted aprical kernels (Griffin, 1974). Schmidt et al. (1978) found that when dogs were given oral doses of Laetrile along with uncooked foods containing B-glucosidases there was a 60% mortality rate. Another study reported by the Cancer Commission of the California Medical Association (1953) indicated that amygdalin administered to mice via gastric intubation was found to be safe at all doses below 300 mg/kg but once the doses reached 400 mg/kg or greater, death occurred in a matter of minutes to one hour. Stock et al. (1978) noted that oral dosages of amygdalin at 500 mg/kg/day were lethal while 250 mg/kg/day was tolerated for at least 19 doses.

The greater toxicity of orally ingested amygdalin is attributed to the presence of the gastrointestinal flora which contain the enzyme beta-glucosidase. Studies by Carter et al. (1980) showed that when conventional rats were given single oral doses of amygdalin (600 mg/kg) they usually died within 2 to 5 hours. On the other hand, germ free rats did not exhibit any visible signs of toxicity after receiving the same dose of amygdalin. Another study was carried out by Newton et al. (1981) to determine the role of the bacterial

flora of the gut in hydrolyzing amygdalin. Using rats, they found the LD 50 of amygdalin to be approximately 522 mg/kg of body weight. However, when rats were pre-treated with the antibiotic Neomycin which reduced the gastrointestinal flora, the rats became less susceptible to amygdalin's toxicity.

A number of isolated cases of oral amygdalin toxicity have been found when there was accidental ingestion of too many kernels. Townsend (1975) reports of a 34 year old man who ingested approximately 48 kernels and soon thereafter exhibited some symptoms of toxicity. He also states that the minimum number of kernels need to induce illness or death is not known. It should be noted that in a few places in the world, there are certain strains of apricot trees that produce seeds containing ten times the concentration of amygdalin found in those trees grown in the United States (Griffin, 1974). Some of these trees may be found in Turkey where it is culturally acceptable to eat apricot kernels. In 1964, a Turkish paper reported nine cases of cyanide poisoning, with two fatalities, from apricot seed ingestion during the period 1957-1962 (Sayre and Kaymakcalan, 1964). It has been reported that five to thirty apricot kernels eaten through the day may be a sufficient preventative amount, but they should never be taken all at one time (Kirschman, 1979). Krebs (1967) suggests a minimum daily intake of fifty milligrams of amygdalin. The average apricot kernel in the United States contains approximately four to five milligrams of amygdalin. Thus, to obtain Krebs's recommended dose at 50 mg, one would have to ingest ten to twelve apricot kernels per day (Griffin, 1974).

Other routes of amygdalin administration have proven to be far less toxic. Two similar studies were carried out in 1975 administering amygdalin intraperitoneally (Laster and Schabel, 1975; Wodinsky and Swiniarski, 1975). Wodinsky and Swiniarski reported that amygdalin MF was non-toxic for tumor-bearing mice when injected at a level of 64 mg/mouse/day for 9 days, and that B-glucosidase could also be administered safely at a dose level of 0.2 mg/mouse. They observed toxicity only when B-glucosidase was administered before doses greater than or equal to 100 mg/kg of amygdalin MF. Studies by Laster and Schabel (1975) show that amygdalin MF alone was less toxic than when given with the activating agent, B-glucosidase. When only amygdalin MF was administered to mice intraperitoneally for nine days it produced 60% mortality, at a dose of 500 mg/kg, 30% mortality at 355 mg/kg, and no deaths at 220 mg/kg. However when B-glucosidase (10 mg/kg/dose) was given in combination with the amygdalin MF, the highest level that could be tolerated by normal mice without exceeding the LD 10 was 53 mg/kg/dose. Experiments by Hill et al. (1976) were carried out using intraperitoneal injections of amygdalin in mice. Their results indicate that at doses ranging from 50-500 mg/kg for 4 days there were no signs of toxicity, but when the dose was increased to 2000 mg/kg for 4 days there was a 5% death rate. Another experiment using intraperitoneal doses of amygdalin in mice was carried out by Stock et al. (1978). They noted that there was no toxicity from properly executed doses of amygdalin as high as 1000 mg/kg/day from 6-28 injections and in one experiment as high as 8000 mg/kg/day for 6 injections. Contrary to Stock's results are data from Khandekar and Edelman (1979) who report that

amygdalin given to Fischer 344 rats in doses of 250, 500, and 750 mg/kg intraperitoneally for five days, caused mortalities of 30.8%, 44.1%, and 56.8%, respectively. However, Stock et al. (1978) responded to these data in a letter to the editor where he stated, "faulty intraperitoneal injections may have caused damage to the intestine by releasing the enzyme B-glucosidase from the bacterial flora, which quickly liberated cyanide from the amygdalin, causing mortality."

A study was performed by Manner et al. (1977) where they injected Jax C57 B1/KsJ mice intramuscularly with doses ranging from 1000-2500 mg/kg for 15 days. They found that daily doses of up to 2000 mg/kg could be used without danger of toxicity. Amygdalin used in cancer therapy on adult humans has been administered in dosages of up to 70 grams by combined oral and parenteral routes without ill effects (Rubin, 1977). More recently, a pharmacologic test was carried out by the National Cancer Institute to look for possible toxic effects in a small number of cancer patients. Six patients entered the study; three received an IV formulation of Laetrile and three received it orally. The patients were also given foods containing the enzyme B-glucosidase. They were all treated as in-patients and were closely monitored with blood and urine samples for cyanide and thiocyanate levels as well as any clinical evidence of cyanide toxicity. The results showed that five of the six patients experienced no toxic effects that could be directly or indirectly ascribed to Laetrile therapy. One patient showed clinical evidence of toxicity only after eating large quantities of raw almonds (Henney, 1980).

PREVENTION STUDIES WITH AMYGDALIN

There are very few controlled laboratory experiments using amygdalin for cancer prevention. In reviewing the literature only one set of two prevention studies using spontaneous tumors in mice could be found (Stock *et al.*, 1978). Both of these experiments were performed by Stock's co-worker, Kanematsu Sugiura. In the first prophylaxis experiment he used CD₈F₁ mice, a strain which develops spontaneous mammary tumors. Mice in the experimental group received daily intraperitoneal injections of amygdalin 6 times per week at a dosage of 1000 mg/kg/day. The control group received 0.5 ml injections of physiological saline. Although five experimental animals were killed accidentally by the injection of amygdalin into the intestine or in the uterine horn of pregnant mice, he still obtained interesting results. In 30 control animals 81% developed lung metastases and 82% tumors. In 24 experimental animals 17% developed lung metastases and 72% tumors. The average number of days for tumor development were 411 and 449 in control and experimental mice, respectively. The second prophylaxis experiment, also performed by Sugiura, tested amygdalin against spontaneous leukemia in AKR mice. The mice were divided into 2 groups, one to receive IP injections of 0.5 ml saline daily six times per week and the other to receive 2000 mg/kg/day of amygdalin. His findings show that in none of the mice was there prevention of the development of leukemia or significant increase in the survival of the mice. However, they do state that it might have been less of a challenge to the amygdalin if younger mice further from the occurrence of leukemia had been used.

Only two other similar laboratory experiments on cancer prevention with amygdalin could be found. However, in these studies transplantable tumors were used instead of spontaneous tumors. One was a study by Reitnauer which was published in 1974. He pretreated 20 out of 40 H strain mice with bitter almonds which were taken in addition to their standard feed in a free food choice. After fifteen days of pretreatment, all 40 mice were inoculated with 10^6 Ehrlich Ascites cells. The 20 control mice lived an average of 21.9 days following the transplant. The 20 mice who received bitter almonds throughout the experiment lived an average of 25.8 days ($p < 0.05$ by t-test). Another experiment was carried out in France in 1977 by Metianu. Ten controls and 10 mice treated subcutaneously two to three times per week for 20 to 25 days with 500 mg/kg of amygdalin were injected with 5×10^8 cells of an adenocarcinoma adapted for mice. The experimental group lived an average of 58 days past the time of tumor take, while the control group averaged 21 days survival. To see if the results could be replicated, he repeated the same experiment and found the experimental group to live 47 days past the time of tumor take, and 27 days survival for the controls. He obtained less noticeable results with higher doses, and observed no effect with amygdalin at 100 mg/kg.

USE OF THE FEMALE C3H/HeJ MOUSE

Among all of the laboratory mammals, the common mouse is the most widely used (Green, 1966). Advantages of using the mouse include easy availability of inbred strains from national or regional stock centers (i.e. Jackson Laboratories), the large amount of information

known on their genetics and biology, low cost, and small size, which minimizes care and space. The latter two advantages are of particular importance when carrying out large scale, long term (2 years) prevention studies such as this one.

The rodent tumor selected to evaluate the anti-tumor properties of naturally occurring amygdalin was the spontaneous murine mammary adenocarcinoma. Mammary tumors (in breeding females) are the most common tumors of inbred strains of mice and are probably the most completely studied of all tumors (Dunn, 1959). Spontaneous mammary tumors from inbred strains of mice form one of the most useful groups of neoplasms for certain investigations in the field of cancer research (Auduvant and McEleney, 1940). Advantages of using this tumor include accessibility to palpation and predictable frequency in a number of inbred strains. Therefore, the mammary tumor has been an invaluable tool for investigations in genetic, viral, hormonal, chemotherapeutic, nutritional and other facets on cancer research (Green, 1966).

Another important reason for using this rodent tumor is that it is a spontaneous type of tumor. There seems to be some basis for considering spontaneous tumors to be a truer model of the situations of medical interest, both in growth characteristics and in treatability (Martin et al., 1975).

The mouse chosen for this study is the female C3H/HeJ strain. This strain of mouse was selected because it has been used previously by investigators in our laboratory (Manner et al., 1978). Also, the C3H strain of mouse is typical of one of the high-incidence strains

produced through brother-and-sister mating. In breeding females, spontaneous mammary tumors are usually observed at about 8½ months and the average duration of life after the tumor is 6 to 7 weeks (Lippincott et al., 1942). Thus, strain C3H females are useful in studies on the occurrence of spontaneous mammary cancer in mice since the high incidence supplies satisfactory controls for experiments in the inhibition of the tumors (Auduvant and McEleney, 1940).

CHAPTER III

MATERIALS AND METHODS

PREVENTION STUDY

For the prevention experiment, one hundred and fifty female C3H/HeJ mice, Mus musculus, were obtained from Jackson Laboratories in Bar Harbor, Maine. These mice were retired breeders and when received were approximately 8 months of age. These mice have a mean life span of approximately 18 months. Female C3H/HeJ mice are genetically bred for approximately a 60% maximum cumulative incidence of mammary tumors (Jackson Laboratories, 1979). The average weight of the mice was 30 grams. Initially, these mice were housed 4 in a cage (plastic shoe-box type) containing an inert bedding called Sanicel.

The environmental conditions were kept constant. Water bottles were checked daily and cages changed routinely. Humidity was kept between 50-55%; room temperature, $23 \pm 2^{\circ}$ C; photoperiod twelve hours of light and twelve hours of darkness. All animals received standard Purina Mouse Chow and tap water ad libitum.

This study was initiated on September 17, 1979. Prior to experimentation, all animals were screened by palpation for the presence of spontaneous mammary tumors. Only those mice without any tumors were used at the start of this study. Forty-five control animals were

maintained on the standard diet above. Eighty experimental animals received apricot kernels ad libitum in addition to their standard diet. The apricot kernels were obtained from American Nutrition Products, Thousand Oaks, California and were stored at 5° C. Apricot kernels are the primary source of amygdalin and on analysis contain 2 to 3% amygdalin and also substantial amounts of protein, unsaturated fatty acids, and minerals (Kirschman, 1973). Evidence of apricot kernel consumption by the animals was noted by observation.

The animals were palpated thoroughly each day until a tumor was found. Once a tumor was found, the length of time for appearance was recorded, and thereafter, the mice were caged separately and observed for tumor growth or recession, longevity, and general appearance. Experimental animals with mammary tumors continued to receive apricot kernels ad libitum. All animals were maintained until death, so that a mortality rate could be established.

TOXICITY STUDIES

Another study was carried out to investigate for any possible toxic effects that might be incurred when chronic low doses of amygdalin are administered via the oral route.

Forty female C3H/HeJ mice without tumors were used for this study. They were caged separately and fed Purina Mouse Chow and tap water ad libitum. The mice were divided into four groups of ten. The first group received a daily dosage of natural amygdalin dissolved in their drinking water. The amount of amygdalin used was equivalent to

3% (the approximate amount of amygdalin in apricot kernels). Another group received a daily dosage of natural amygdalin equivalent to 250 mg/kg. The third group received daily dosages of natural amygdalin which were increased each day until toxic effects were noted. In the latter two groups the amygdalin was dissolved in distilled, deionized water and administered orally via gastric incubation after methods of Simmons and Brick (1970). The last group was maintained as a control group and received distilled, deionized water via gastric intubation in a dosage volume equivalent to the experimental groups. The amygdalin used was obtained from Sigma Chemical Company, St. Louis, Missouri and was approximately 99% pure. The amygdalin solutions were prepared fresh daily.

All animals were weighed at the beginning of the experiment and again at the end and weight changes were noted. Observations were made twice daily, and all signs of toxicity were recorded.

CHAPTER IV

RESULTS

PREVENTION STUDY

The mice in this study were categorized into two groups. Group 1 (controls) represents the mice that did not receive apricot kernels and Group 2 (experimental) represents the mice that did receive apricot kernels.

The number of mice that formed spontaneous mammary tumors was examined in both groups. The results can be seen in Figure 5. In the control group, 77.8% of the animals formed tumors, and in the experimental group 78.8% of the animals formed tumors. This does not represent a significant difference.

The mean time for the tumors to develop was also examined. The results are represented in Figure 6. The mean number of months required for tumor formation in the control group was 5.9 ± 3.5 months and in the experimental group it was 6.8 ± 3.6 months. This was not found to be significantly different.

This experiment also evaluated the effects of apricot kernels on the mean life span of the mice. Figure 7 shows a comparison between the non-tumorous control and experimental animals and the tumorous control and experimental animals. Non-tumorous mice in the control group lived a mean of 18.8 ± 3.3 months and those in the experimental group lived a

FIGURE 5. Percentage of tumorous mice in control and experimental groups.

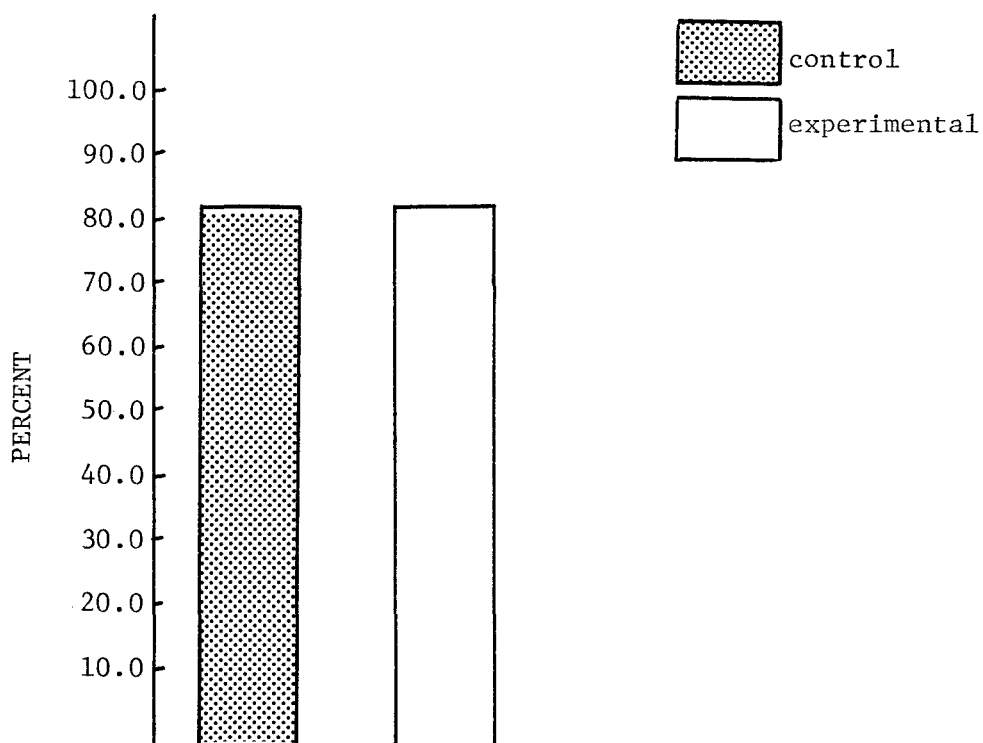

FIGURE 6. Mean number of months required for tumor formation.

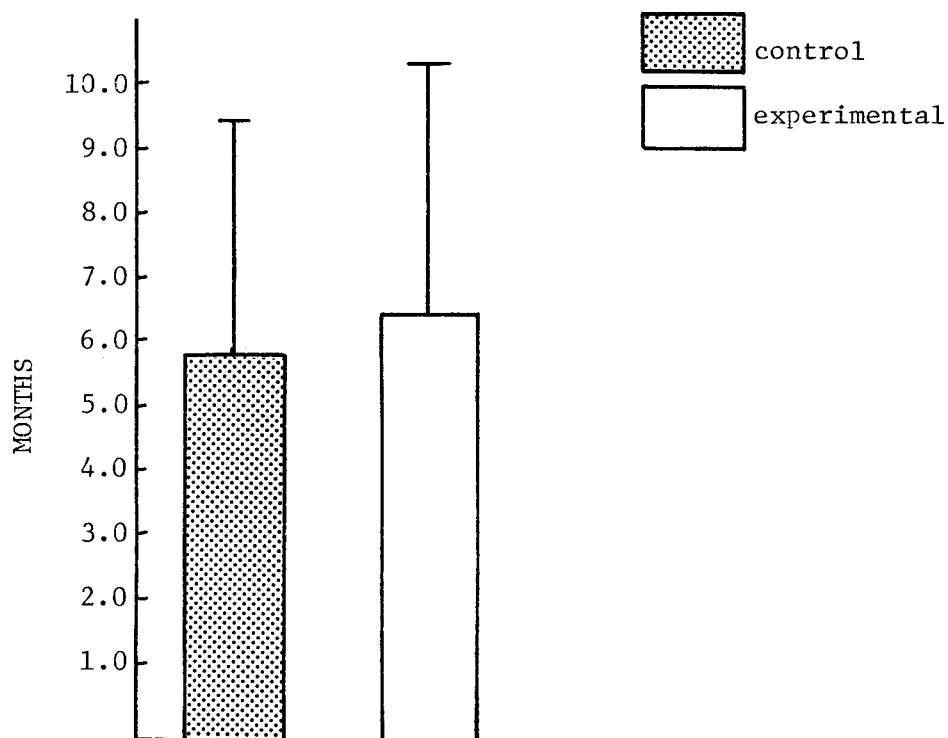
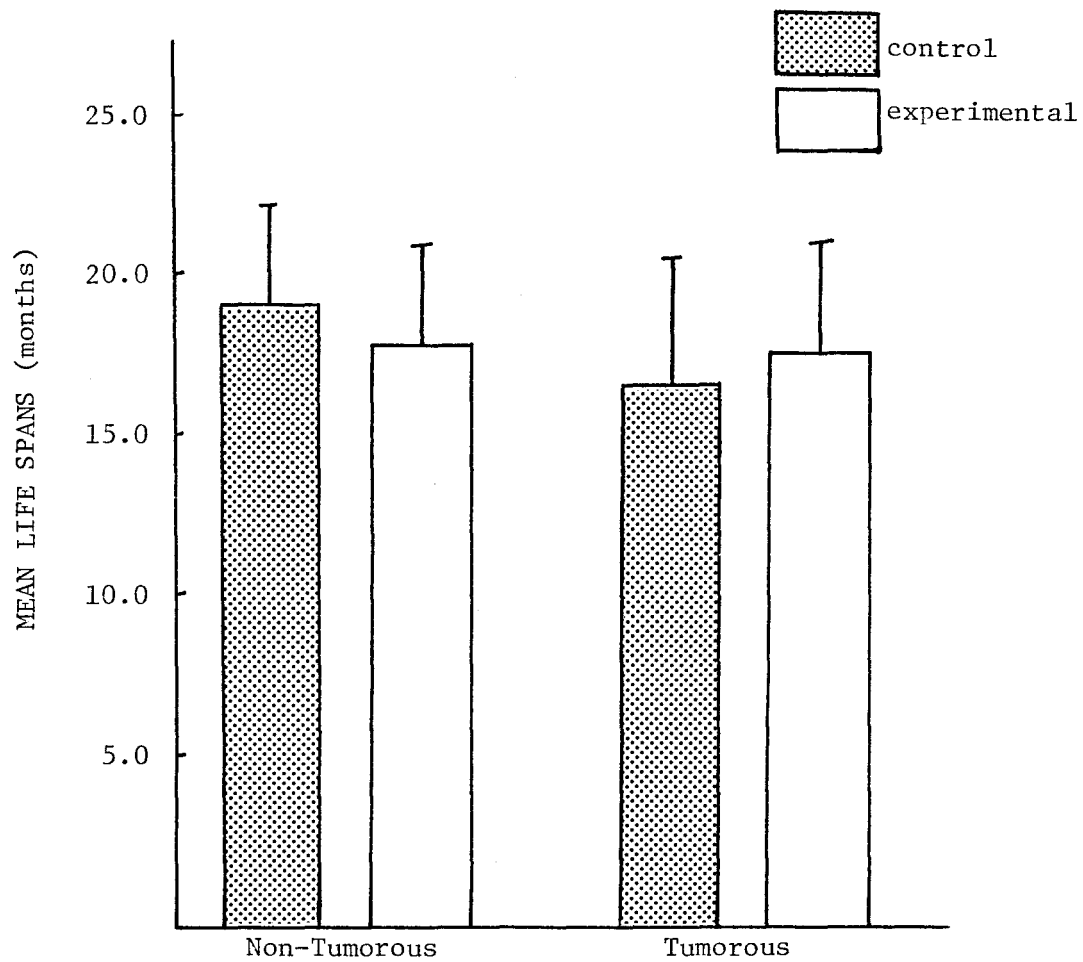

FIGURE 7. Mean life span of female C3H/HeJ mice.



mean of 18.0 ± 2.9 months. Tumorous mice in the control group lived a mean of 16.6 ± 3.8 months and tumorous mice in the experimental group lived a mean of 17.6 ± 3.5 months. The difference in the mean life span of mice in either of these groups was not found to be significantly different.

To ensure thorough evaluation of the data, comparisons were made between the mean life span of tumorous mice in the control group and non-tumorous mice in both the control and experimental groups. Comparisons were also made between the mean life span of tumorous mice in the experimental group and non-tumorous mice in the control and experimental groups. In both of these comparisons, there could be found no significant difference in the mean life span of the mice (see Figure 8).

TOXICITY STUDY

The results from the toxicity study are given in Table III. In mice given a 3% solution of amygdalin, seven out of ten mice died after the first day and the three remaining mice were dead after the second day. This represents a cumulative mortality of 100%. When amygdalin was administered in an oral dose of 250 mg/kg/day for fifteen days, there was one death out of ten animals. When the dose was escalated to 400 mg/kg/day for fifteen days there were five deaths after one day; five more deaths after two days. This represents a cumulative mortality of 100% and suggests that the LD_{50} of orally ingested amygdalin lies approximately around this dose. In the control group which received distilled, deionized water by gastric intubation, there was one death out of ten animals.

FIGURE 8. Comparison between tumorous and non-tumorous control and experimental mice.

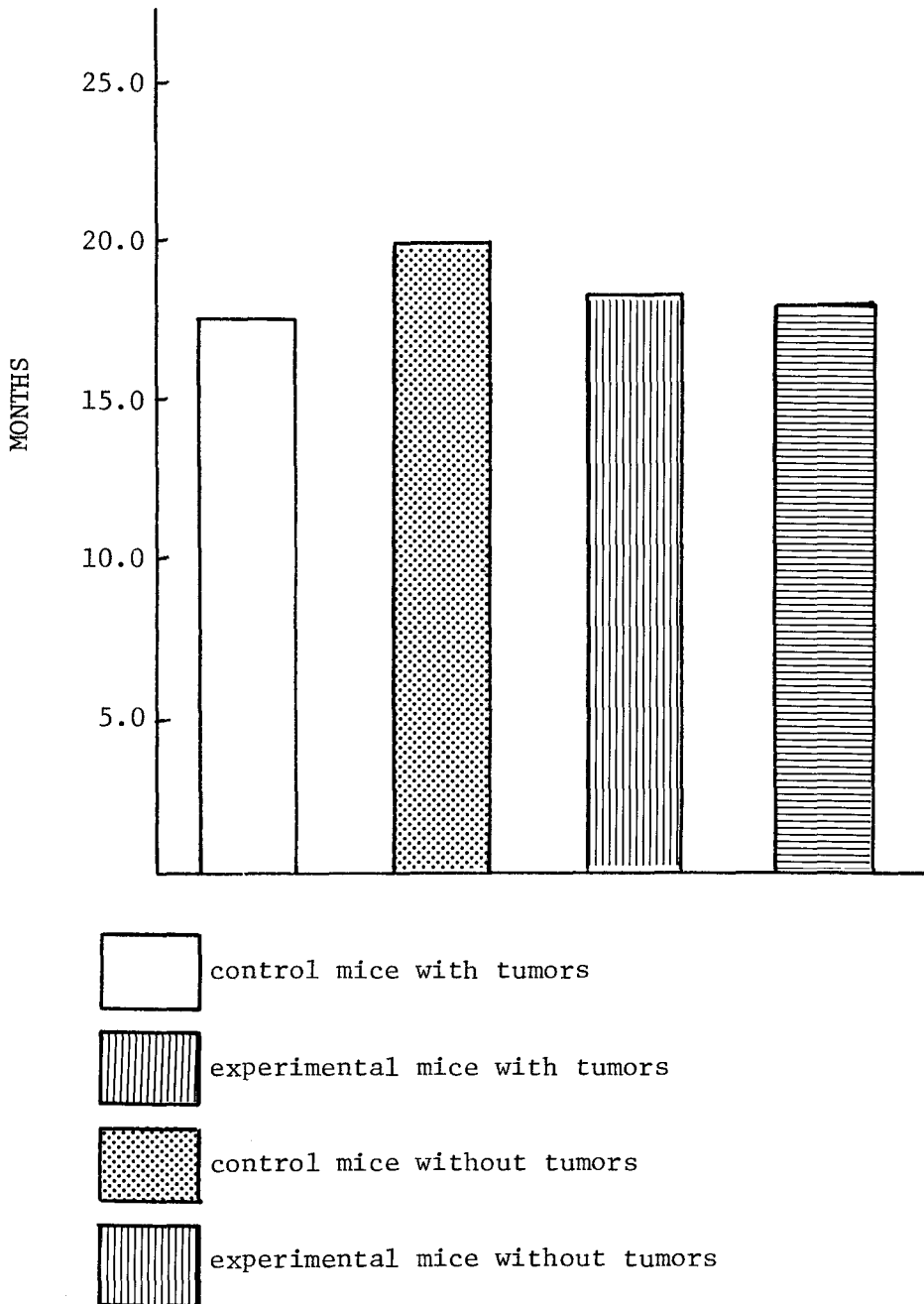

TABLE III. Effects of orally ingested amygdalin on mortality of female C3H/HeJ mice.

Group	Dose of Amygdalin	No. of Animals	Mortality Distribution (Day)													Mortality %		
			1	2	3	4	5	6	7	8	9	10	11	12	13		14	15
A	3% Solution	10	7	3														100
B	250 mg/kg	10	0	0	0	1	0	0	0	0	0	0	0	0	0	0	0	10
C	400 mg/kg	10	5	5														100
D	Controls	10	0	0	1	0	0	0	0	0	0	0	0	0	0	0	0	10

CHAPTER V

DISCUSSION

These studies on the toxicity and cancer preventive effects of orally ingested natural amygdalin were performed to help provide further information about the importance of this substance in everyday human use. They are important because it is estimated that 70,000 people in the United States alone have used amygdalin in an attempt to fight cancer and 22 states have legalized its use (Sun Times, 1981). Also, apricot kernels and similar pits and seeds are sold in health food stores and are widely promoted as having disease preventive or curative properties (Townsend and Boni, 1975).

In the prevention study, apricot kernels were given to female C3H/HeJ mice along with their standard feed in a free food choice. The experimental design was similar to that of Reitnauer (1974) and should simulate the same procedures that are used in humans for cancer prevention. One drawback with this design, however, is that there is no way of determining with any degree of certainty the precise amount of amygdalin that was ingested by the mice. Thus, the possibility exists that some of the mice in the experimental group may not have eaten the apricot kernels at all. However, based on observations there was positive evidence of consumption of the apricot kernels by all of the mice. Apricot kernels were chosen because they are the primary source of

amygdalin and are commonly used by proponents of amygdalin for prevention of cancer.

The results from this preliminary prevention study appear to indicate that apricot kernels do not prevent the formation of spontaneous mammary tumors in female C3H/HeJ mice, nor do they appear to prolong the onset of tumor formation (Figures 5 and 6). In the experimental group, the formation of tumors was delayed by a mean of 0.93 months, but this was not found to be statistically significant using a corrected two-tailed Student's t-test. These data confirm the results of Stock et al. (1978) who found that amygdalin injected intraperitoneally had no significant preventive effect on the formation of spontaneous mammary tumors in CD₈F₁ mice and spontaneous leukemia in AKR mice.

This study also analyzed the effects of the apricot kernels on the longevity of the mice. The mice in the experimental group that formed tumors lived a mean of 0.99 months longer than those in the control group that formed tumors, but this was not found to be significantly different. But no significant difference could be found in the mean life span of the mice that didn't form tumors in the control and experimental groups (Figure 7). These results seem to indicate that the apricot kernels are not having any toxic effects which would alter the life span of the experimental mice.

At this time it seems appropriate to mention one other factor that may lend some error to the interpretation of the results. When handling the data statistically, only the mean age of the mice was

known when they were obtained from the supplier. Therefore, the data, which was recorded in days, was converted to months. This was done to compensate for any possible sample error.

Several important assessments can be made from the data in the toxicity studies. In the mice that received 3% amygdalin in their drinking water, there was a cumulative mortality of 100%. These results are agreeable with those found elsewhere in the literature. In an article by Sayre and Kaymakcalan (1964) it indicates that amygdalin present in the seed is harmless as such. However, when the seed is crushed and the pulp is placed in the presence of water, the catalysis of amygdalin is enhanced and the amygdalin is broken down into its constituent parts, one of them being hydrocyanic acid. The results of this experiment would explain the report of a 34 year old man who developed symptoms of cyanide poisoning after crushing up 48 apricot kernels and mixing them with milk and honey before ingesting them (Townsend and Boni, 1975). These results also seem to confirm the results of Schmidt et al. (1978) who found that sweet almonds (which contain the enzyme B-glycosidase), amygdalin and water mixed together in a blender then administered to dogs after various incubation times caused toxic effects. In a nutrition almanac by Kirschman (1979) it states, "it is not considered desirable to prepare a slurry of ground up kernels (as in a solution of water, milk, or orange juice) and then let it stand for long periods of time before consumption." Thus, the results from this present toxicity study support this statement as well as the previously mentioned studies of Schmidt et al. and Townsend and Boni.

The present toxicity studies also looked at the daily oral dose of amygdalin that could be tolerated by the mice and the oral dose of amygdalin required to exhibit toxic effects. It may be concluded from the data that daily oral doses of amygdalin at 250 mg/kg/day are non-toxic in mice, but when the dosage is increased to 400 mg/kg/day there is a 50% mortality rate. These results confirm those obtained by the Cancer Commission of the California Medical Association (1953). Although one death was found in the 250 mg/kg/day group, this was not found to be significant when compared with the controls. The cause of death could be attributed to stress or trauma as a result of administering the solutions by gastric intubation.

As proposed by advocates of amygdalin, the number of apricot kernels that should be eaten for a preventive effect is five to thirty kernels (Krebs, 1967; Kirschman, 1979). The average apricot kernel grown in the United States contains approximately four to five milligrams of amygdalin (Griffin, 1974). Using this average figure, the amount of amygdalin in five to thirty kernels would be 25 to 150 mg/day. For a 70 kg man, this is 0.36 to 2.14 mg/kg/day. As mentioned previously the dose required to produce toxic effects in mice was found to be 400 mg/kg/day and since humans are seven times more sensitive to the lethal effects of standard chemotherapeutic agents than mice (Freireich et al., 1966) this translates into 57 mg/kg/day for humans. Therefore, it appears that the recommended dose of amygdalin for prevention would not appear to be toxic in humans. However, as in any experiment using laboratory animals one must be extremely cautious about extrapolations

from observations on mice directly to humans (Good, 1981).

In summary, the data presented here indicate that apricot kernels by themselves have no real important effects on the inhibition of tumor growth in mice. The results from the toxicity studies do show that when natural amygdalin is ingested in biologically rational doses it is non-toxic. One point that should be mentioned is that the exact amount of amygdalin that was ingested by the mice in the prevention study was unknown, therefore the possibility exists that the dosage of amygdalin obtained by the mice was too low to have had a preventive effect. Future studies on naturally occurring amygdalin could be carried out using a Mouse Chow with various known concentrations of amygdalin incorporated into it and caging the mice separately. That way the amount of amygdalin consumed by the mice could be more accurately monitored.

Another explanation for the ineffectiveness of the apricot kernels in preventing tumor formation is the fact that they were the only modality used. In previous studies by Manner et al. (1978), it was found that amygdalin used alone was not effective in suppressing tumor formation, but when used in conjunction with a complete metabolic therapy program, it was found to be effective. In light of this fact, a future experiment on cancer prevention should be carried out using naturally occurring amygdalin in conjunction with a complete metabolic program.

LITERATURE CITED

- Auduvant, H.B. and W.J. McEleney. 1940. Spontaneous tumors in a subline of strain C3H mice. J. Nat. Cancer Inst. 1:737-744.
- Barman, T.E. 1969. Enzyme Handbook. Springer-Verlag, New York.
- Beard, John. 1902. Embryological aspects and etiology of cancer. Lancet i:1758.
- Beard, Howard. 1958. A New Approach to the Conquest of Cancer, Rheumatic and Heart Diseases. Pageant Press, Inc., New York.
- Brown, W.D., C.D. Wood and A.N. Smith. 1960. Sodium cyanide as a cancer chemotherapeutic agent. Ann. J. Obstet. Gyn. 80:907-918.
- Burk, D. 1971. Hyperthermy of cancer cells with amygdalin-glucosidase, and synergistic action of derived cyanide and benzaldehyde. Panminerva Medica 13:520-522.
- Cancer Commission of the California Medical Association. 1953. The treatment of cancer with laetriles. Calif. Med. 78(4):320-326.
- Carter, J.H., M.A. McTafferty and P. Goldman. 1980. Role of the gastrointestinal microflora in amygdalin (laetrile)-induced cyanide toxicity. Biochem. Pharmacology 29:301-304.
- Conchie, J., A.J. Hay and G.A. Levvy. 1961. Mammalian glycosidases. J. Biochem. 79:324.
- Culbert, M. 1974. Vitamin B-17: Forbidden Weapon Against Cancer. Arlington House Publ, New Rochelle, New York, pp. 50.
- Dunn, T.B. 1959. Morphology of mammary tumors in mice. In: F. Homburger (Ed.), The Physiopathology of Cancer, 2nd Ed., pp. 38-44. Hoeber-Harper, New York.
- Ferris, J.P. 1970. In: The Chemistry of the Cyano Group, Z. Rappaport (Ed.), pp. 718-739. Interscience Publishers, New York.
- Fishman, W.H. and A.J. Anlyan. 1947. A comparison of the B-glucuronidase activity of normal, tumor, lymph node tissues of surgical patients. Science 106:66-67.
- Fishman, W.H. and A.J. Anlyan. 1947. The presence of B-glucuronidase activity in cancer tissues. J. Biol. Chem. 169:449-450.

- Fishman, W.H., J.R. Baker and P.R.F. Borges. 1959. Localization of B-glucuronidases in some human tumors. Cancer 12:240-245.
- Freireich, E.J., E.A. Gehan, D.T. Raif, E.S. Schmidt and H.E. Skipper. 1966. Cancer Chemotherapy Reports 50(4):219-244.
- Giordano, G., A. Violante, G. Lerenzetti and U. Sapiro. 1956. Rhodanese activity of the neoplastic and hemopoietic tissue of rats with myeloma in leukemic phase. Biochem. Appl. 3:284.
- Good, R.A. 1981. Can cancer be prevented? Therapaeia pp. 30-39.
- Green, Earl. 1966. Biology of the Laboratory Mouse. The Blakiston Div., McGraw-Hill Book Company, New York.
- Greenberg, David. 1975. The vitamin fraud in cancer. West. J. Med. 122: 345-348.
- Griffin, G. Edward. 1974. World Without Cancer. America Media, Calif.
- Haisman, D.R. and D.J. Knight. 1967. Enzymatic hydrolysis of amygdalin. Biochem. J. 103:528-534.
- Halstead, Bruce. 1977. Amygdalin (Laetrile) Therapy For the Nutritional Support and Control of Cancer. Life and Health Medical Group, Redlands, California.
- Henney, J. 1980. National Cancer Institute 1980 studies of laetrile. Medical Times 108:36-47.
- Hill, G., T. Shine, H. Hill and C. Miller. 1976. Failure of amygdalin to arrest B-16 melanoma and BW5147 AKR leukemia. Can. Res. 36: 2102-2107.
- Himwich, N.H. and J.P. Saunders. 1948. Enzymatic conversion of cyanide to thiocyanate. Am. J. Physiol. 153:348-354.
- Hodges, F.B. 1974. Annual Bulletin, California State Department of Health.
- Holden, C. 1976. Laetrile: "quack" cancer remedy still brings hope to sufferers. Science 193:982-985.
- Humbert, J.R., J.H. Tress and K.T. Braico. 1977. Fatal cyanide poisoning: Accidental ingestion of amygdalin (letter). JAMA 238:482.
- Karczag, I. 1928. Die chemotherapie des mausekarzinomas durch fermentgifte. Archiv. Exper. Zellforsch. 6:178-181.

- Kerr, L.M.H., J.G. Campbell and G.A. Levvy. 1949. B-glucuronidase as an index of growth in the uterus and other organs. Biochem. J. 44: 487-494.
- Khandekar, J.D. and H. Edelman. 1979. Studies of amygdalin (laetrile) toxicity in rodents. JAMA 242:169-171.
- Kirschman, J.D. 1979. Nutrition Almanac, McGraw-Hill Book Company, New York, pp. 35-36.
- Krebs, Ernst T., Jr. 1946. Trophoblastic elements in cancer. Science 104:302.
- Krebs, Ernst T., Jr. 1967. The Nitrilosides in Plants and Animals. The Laetriles-Nitrilosides in the Prevention and Control of Cancer. McNaughton Found., Sausalito, California.
- Krebs, Ernst T., Jr. 1970. The nitrilosides (Vitamin B-17): Their nature, occurrences and metabolic significance antineoplastics vitamin B-17. Journ. Appl. Nutr. 22:75-78.
- Krebs, Ernst T., Jr., E.T. Krebs, Sr. and H. Beard. 1950. The unitarian or trophoblastic thesis of cancer. Medical Record 163:149-174.
- Krebs, Ernst T., Jr. and E.T. Krebs, Sr. 1958. British Patent No. 788, 855.
- Lang, K. 1933. Die rhodanbildung im tierkooper. Biochem. Z. 259:243-256.
- Larson, Gena. 1972. Is there an anti-cancer food? Prevention, April.
- Laster, W. and F.M. Schabel. 1975. Experimental studies of the anti-tumor activity of amygdalin MF(NSC-15780) alone and in combination with B-glucosidase (NSC-128056). Cancer Chemotherapy Reports 59(1):951-965.
- Levy, G.A. and C.S. Marsh. 1960. B-glucuronidase. In: Boyer, P.D., H. Lardy and K. Myrback (Eds.) The Enzymes, Vol. 4, 2nd Ed., Academic Press, New York, pp. 397-407.
- Levy, G.A. and J. Conchle. 1966. B-glucuronidase and the hydrolysis of glucuronides. In: Glucuronic Acid - Free and Combined, Dutton, G.J. (Ed.). Academic Press, New York, pp. 301-357.
- Lewis, W.H. and P.F. Elvin-Lewis. 1977. Medical Botany: Plants Affecting Man's Health. John Wiley & Sons, Inc., New York.
- Liebig, J. and F. Wohler. 1837. Uber die blidungedes bitter-mandelols. Annalen der Chemie und Pharmacie 22:1-24.

- Lippincott, S.W., J.E. Edwards, H.G. Grady and H.L. Stewart. 1942. A review of some spontaneous neoplasms in mice. J. Nat. Cancer Inst. 3:199-210.
- Manner, Harold W., S. DiSanti and T. Michalsen. 1977. The non-toxicity of amygdalin to laboratory mice. Sci. Biol. J. May-June, pp. 347-348.
- Manner, Harold W., S. DiSanti and T.L. Michalsen. 1978. The Death of Cancer. Advanced Century Publishing Corp., Chicago, Illinois.
- Martin, D.S., R.A. Fugmann, R.L. Stolfi and P.E. Hayworth. 1975. Solid tumor animal model therapeutically predictive for human breast cancer. Cancer Chemotherapy Reports, Part 2, vol. 5, pp. 89-109.
- Maxwell, L.C. and F. Bischoff. 1933. Studies in cancer chemotherapy, XI. The effect of Co, HCN, and pituitaries upon tumor growth. J. Pharmacol. Exp. Ther. 49:270.
- Mendel, B., H. Rudney and M.C. Bowman. 1946. Rhodanese and the Pasteur effect. Cancer Research 6:495.
- Merck Index. 1976. Merck Index, M. Windholz (Ed.), Merck & Co., Rahway, New Jersey. 1313 pp.
- Metianu, T. 1977. Contribution a l'etude de la toxicite et de l'activite antitumorale de l'amygdaline. Bull. Acad. Vit. de France 50:365-370.
- Mlettlinen, T.A. and E. Leskinen. 1970. Glucuronic acid pathway. In: Metabolic Conjugation and Metabolic Hydrolysis, W.H. Fishman (Ed.). Academic Press, New York, pp. 157-237.
- Montgomery, R.D. 1969. Cyanogens. In: Toxic Constituents of Plant Food-stuffs, I.E. Liener (Ed.). Academic Press, New York, pp. 143-157.
- Newton, G.W., E.S. Schmidt, J.P. Lewis, et al. 1981. Amygdalin toxicity studies in rats predict chronic cyanide poisoning in humans. West J. Med. 134:97-103.
- Oke, O.L. 1969. The role of hydrocyanic acid in nutrition. World Rev. Nutr. Diet. 11:170-198.
- Osuntokun, B.O. 1970. Cassava diet and cyanide metabolism in Wistar rats. Brit. J. Nutr. 24:797.
- Pamel, L.H. 1911. A Manual of Poisonous Plants. Torch Press, Cedar Rapids, Iowa.

- Perry, Isabella. 1935. The effect of prolonged cyanide treatment on body and tumor growth in rats. Am. J. Can. 25:592-598.
- Pijoan, M. 1942. Cyanide poisoning from choke cherry seed. Am. J. Med. Sci. 204:550-553.
- Reitnauer, P.G. 1974. Prolongation of life in tumor-bearing mice by bitter almonds. Arch. Geschwulstforsch 42(4):135-137.
- Robiquet, Boutron. 1830. Les amanides ameres et l'huile volatile qu'elles fournissent. Ann. Chim. Phys. 44:352-382.
- Rosenthal, O. 1948. The distribution of Rhodanese. Fed. Proc. 7:181-182.
- Rubin, D. 1977. Article: B-17 breakthrough in Israeli cancer research. The Choice 3(6):1-9.
- Sadoff, L., K. Fuchs and J. Hollander. 1978. Rapid death associated with laetrile ingestion. JAMA 239:1532.
- Sayre, J.W. and S. Kaymakcalan. 1964. Cyanide poisoning from apricot seeds among children in central Turkey. N. Engl. J. Med. 270:1113-1115.
- Schmidt, E.S., G.W. Newton, S.M. Saunders, J.P. Lewis and E.E. Conn. 1978. JAMA 239:943.
- Simmons, M.L. and J.O. Brick. 1970. The Laboratory Mouse-Selection and Management. Prentice-Hall, Inc., New Jersey.
- Stock, L.C., D.S. Martin, K. Sugina, et al. 1978. Antitumor tests of amygdalin in spontaneous animal tumor systems. J. Surg. Oncol. 10:89-123.
- Sun Times. 1981. Laetrile found "not effective" in federal study.
- Timms, M. and Z. Zar. 1978. Natural Sources of B-17, Laetrile. Celestial Publ., Milbra, California.
- Townsend, W.A. and B. Boni. 1975. Cyanide poisoning from apricot kernels. Calif. Morbidity 51:427.
- Trube-Becker, E. 1965. A bitter pill. Food and Cosmetics Toxicology 3:358.
- Westley, J.W. 1973. Rhodanese. Adv. Enz. 39:327-368.
- White, A., P. Handler and E. Smith. 1973. Principles of Biochemistry, 5th Ed., McGraw-Hill Book Company, New York, New York.

Williams, R.P. 1959. Detoxification Mechanisms, 2nd Ed., John Wiley & Sons, Inc., New York, New York. pp. 332-334.

Wodinsky, I. and Joseph Swiniarski. 1975. Antitumor activity of amygdalin MF (NSC-15780) as a single agent and with B-glucosidase (NSC-128056) on a spectrum of transplantable rodent tumors. Can. Chem. Rep. 59:939-950.

APPROVAL SHEET

The thesis submitted by Gareth Eli Shemesh has been read and approved by the following committee:

Dr. Anthony J. Nappi, Director (for Dr. Harold M Manner)
Chairman and Professor, Department of Biology, Loyola

Dr. William C. Cordes
Assistant Professor, Department of Biology, Loyola

Dr. Amrik S. Dhaliwal
Professor, Department of Biology, Loyola

The final copies have been examined by the director of the thesis and the signature which appears below verifies the fact that any necessary changes have been incorporated and that the thesis is now given final approval by the Committee with reference to content and form.

The thesis is therefore accepted in partial fulfillment of the requirements for the degree of Master of Science.

22 April 83
Date

A. Nappi
Director's Signature